

STANDARD

DOPPIO VETRO / DOUBLE GLAZING

Produced with:
uni_one
TECHNOLOGY





ed. 00/02.2024

Indice generale/*General index*

Fattibilità <i>Feasibility</i>	pag.3
Scheda tecnica <i>Technical data sheet</i>	pag.4
Disegni tecnici/ <i>Technical drawings</i> Sezioni finestra <i>Window sections</i>	pag.6
Sezioni scambio battuta centrale <i>Installation examples</i>	pag.9-10
Sezioni porta <i>Door sections</i>	pag.11..18
Traversi intermedi anta e inglesine <i>Intermediate rails and Georgan bars</i>	pag.19..22
Sezione porta con serratura <i>Entrance door</i>	pag.23..31
Finestra con vetro fisso <i>Fixed Light</i>	pag.32..35
Sezioni montanti e traversi intermedi telaio <i>Frame transom and mullion</i>	pag.36..38
Telai per ristrutturazione FD305-FD312 <i>Wooden frames profiles for renovation</i>	pag.39..41
Sezioni bugna/pannelli <i>Ashlar panels</i>	pag.42-43
Finestre accoppiate <i>Connected windows</i>	pag.44..46
Sezioni finestra con tapparella <i>Roller Shutter</i>	pag.47
Sezioni finestra con zanzariera <i>Mosquito net</i>	pag.48-49
Sezioni porta d'ingresso con fisso laterale <i>Entrance door with fixed light</i>	pag.50..53
Sezioni Scorrevole complanare <i>Coplanar sliding window/door</i>	pag.54-55

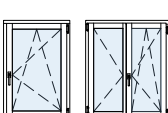
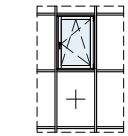
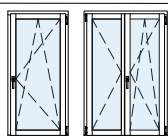
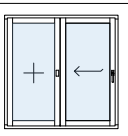
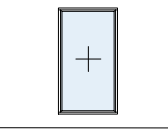
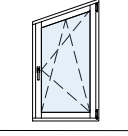
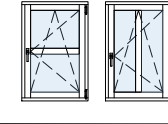
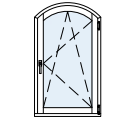
Esempio di principali tipologie realizzabili

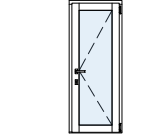
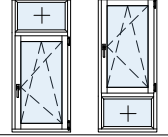
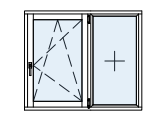
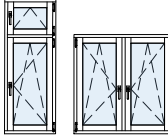
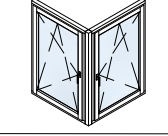
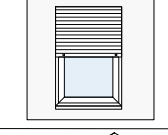
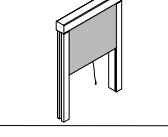
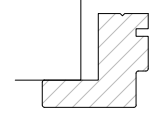
I)Finestra A/R D)Flügel E)Ventana F)Fenêtre EN)Window		✓	I)Inserimento in facciata D)Einspannelement für Fassade E)Encaje en fachada F)Prédisposition pour l'insertion en façade EN)Insertion window for curtain wall		⊘
I)Portafinestra A/R D)Tür E)Puerta ventana F)Porte fenêtre EN)Window door		✓	I)Scorrevole parallelo D)Paralle-Schiebefenster E)Corredera paralela F)Coulissant parallèle EN)Parallel-sliding windows		✓
I)Finestra con anta fissa/Finestra con vetro fisso D)Fenster mit Fixverglasung E)Ventana con cristal fijo F)Fenêtre avec vitre fixe EN)Fixed Light		✓	I)Fuorisquadra D)Schrägelement E)Fuera de squadra F)Hors-équerre EN)Shaped window		⊘
I)Traverso intermedio anta D)Sprossen in Flügel E)Travesanos intermedios de la hoja F)Traverses intermédiaires vantail EN)Sash intermediate rails		✓	I)Serramento ad arco D)Rundbogenfenster E)Cerramiento curvado F)Châssis cintré EN)Curved window		⊘
I)Inglesine(con incollaggio al vetro) D)Vorsatzsprosse E)Travesanos F)Traverses EN)Georgian bars		✓	I)Serramento ad impacchettamento(Libro) D)Falttür E)Cerramiento a libro F)Coulissante pliante EN)Sliding folding window		⊘
I)Porta con serratura D)Tür mit schloss E)Puerta con cerradura F)Porte avec serrure EN)Window door with lock		✓			
I)Finestra con sopra/sottoluce fisso D)Fenster mit Ober/Unterlicht fix E)Ventana con sobreluz/antepecho fijo F)Fenêtre avec partie fixe EN)Fixed glazing		✓			
I)Finestra con fisso laterale D)Fenster mit seitlichen Fixelement E)Ventana con fijo lateral F)Fenêtre avec fixe latéral EN)Side-fixed glazing		✓			
I)Piantoni e traversi intermedi telaio D)Rahmen mit Kämpfer und Setzholz E)Montantes y travesaños intermedios marco F)Meneaux et traverses intermédiaires dormant EN)Sash intermediate mullions and transoms		✓			
I)Finestre accoppiate D)Gekoppelte Fenster E)Ventanas acopladas F)Fenêtres assemblées EN)Connection between windows		✓			
I)Inserimento per tapparelle D)Rolladenführungsprofile E)Encaje para celosías F)Prédisposition pour volets roulants EN)Arrangement for roller shutters		✓			
I)Inserimento zanzariere D)Einführung Fliegengitter E)Encaje para mosquiteras F)Prédisposition pour moustiquaires EN)Arrangement for fly screens		✓			
I)Telaio per ristrutturazione D)Rahmen für Renovierung E)Marco para rehabilitación F)Cadre pour rénovation EN)Frame for renovation		✓			

Per i limiti dimensionali, di portata e di fattibilità delle ante fare riferimento ai cataloghi tecnici del proprio fornitore di ferramenta.
Please refer to your hardware supplier's technical catalogues for sash size, load-bearing capacity and feasibility limits.

STANDARD

DOPPIO VETRO **U_w=1,2 W/m²K**



Materiale		Legno-Alluminio
Isolamento termico		U _w = 1,2 W/m ² K
Vetrocamera		Doppio vetro spessore 28-32mm
Isolamento acustico		R _w fino a 40 dB
Ferramenta di sicurezza		Fino a RC2
Dimensioni in mm.		
Spessore anta		83,5 x 70mm
Spessore telaio		77,5 x 70mm
Sezione a vista anta + telaio		106mm
Sezione a vista nodo a 2 ante		116mm
Permeabilità all'Aria		CLASSE 4
Tenuta all'Acqua		CLASSE E1050
Resistenza al carico del Vento		CLASSE C5

I valori di isolamento termico sono calcolati secondo la norma UNI EN 10077/1-2018, UNI EN 10077/2-2018, UNI EN 10456-2008, UNI EN 673-2011, in riferimento ad un serramento a 1 anta LxH (1230x1480mm, ψ_g = 0,04 W/mK)

Le prestazioni aria-acqua-vento sono certificate in riferimento ad un serramento a 2 ante LxH (1500x1500mm)

I valori di isolamento acustico sono certificati in riferimento ad un serramento a 2 ante LxH (1500x1500mm)

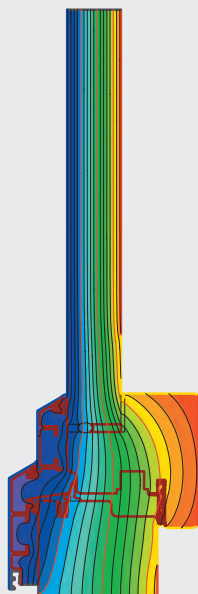

**STANDARD - vetro 28mm
LEGNO TENERO (SOFT WOOD)
U_f = 1,2 W/m²K**

U _g W/m ² K		U _w W/m ² K
1,0	->	1,2
1,1	->	1,2
1,2	->	1,3
1,3	->	1,4
1,4	->	1,4
1,5	->	1,5
1,6	->	1,6

Tavole tecniche
Technical Drawings

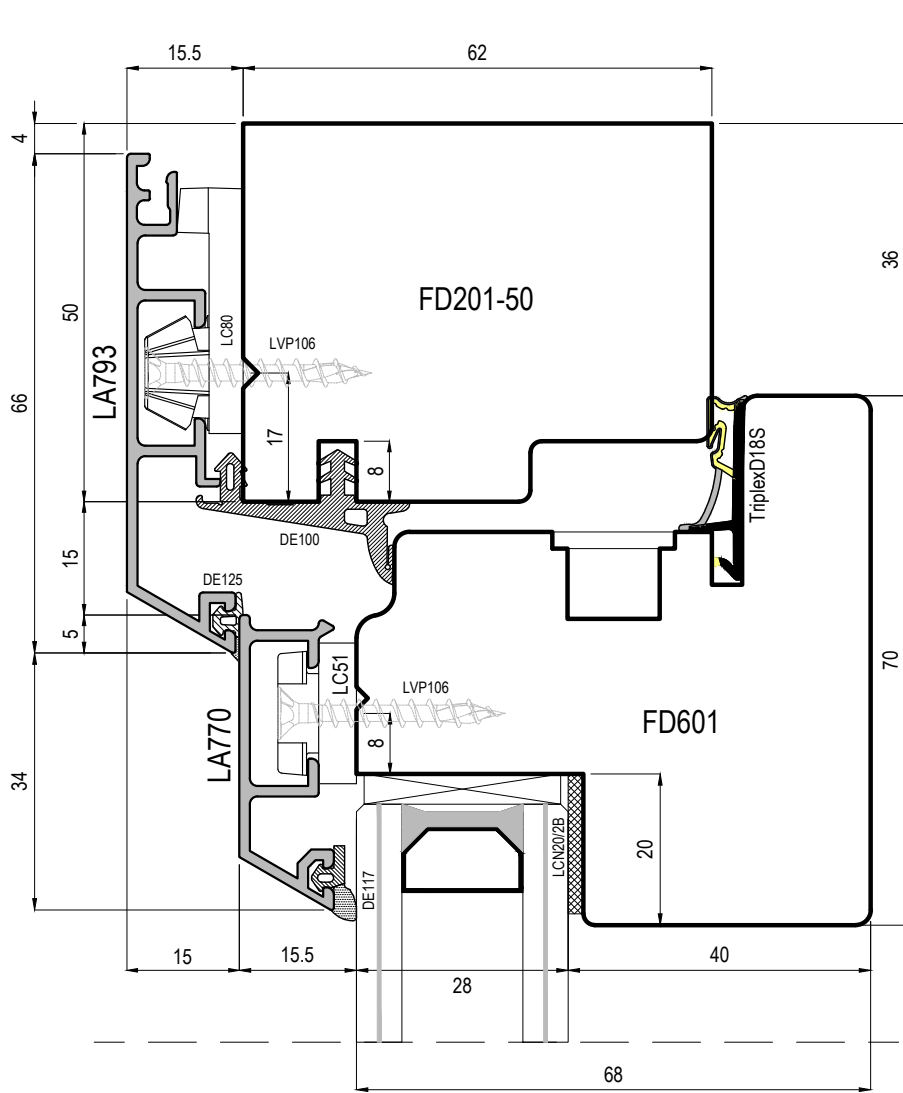

Coprifili in legno

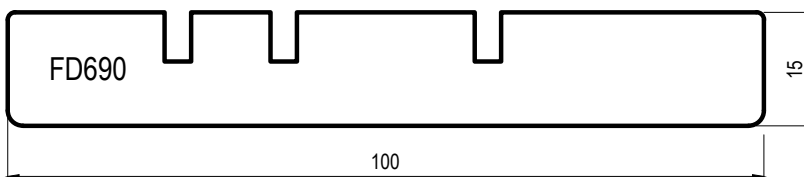
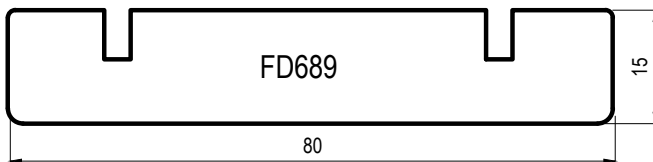
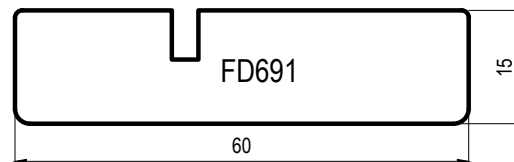
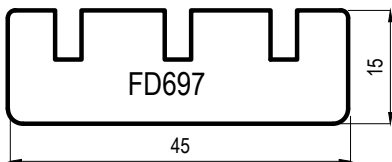

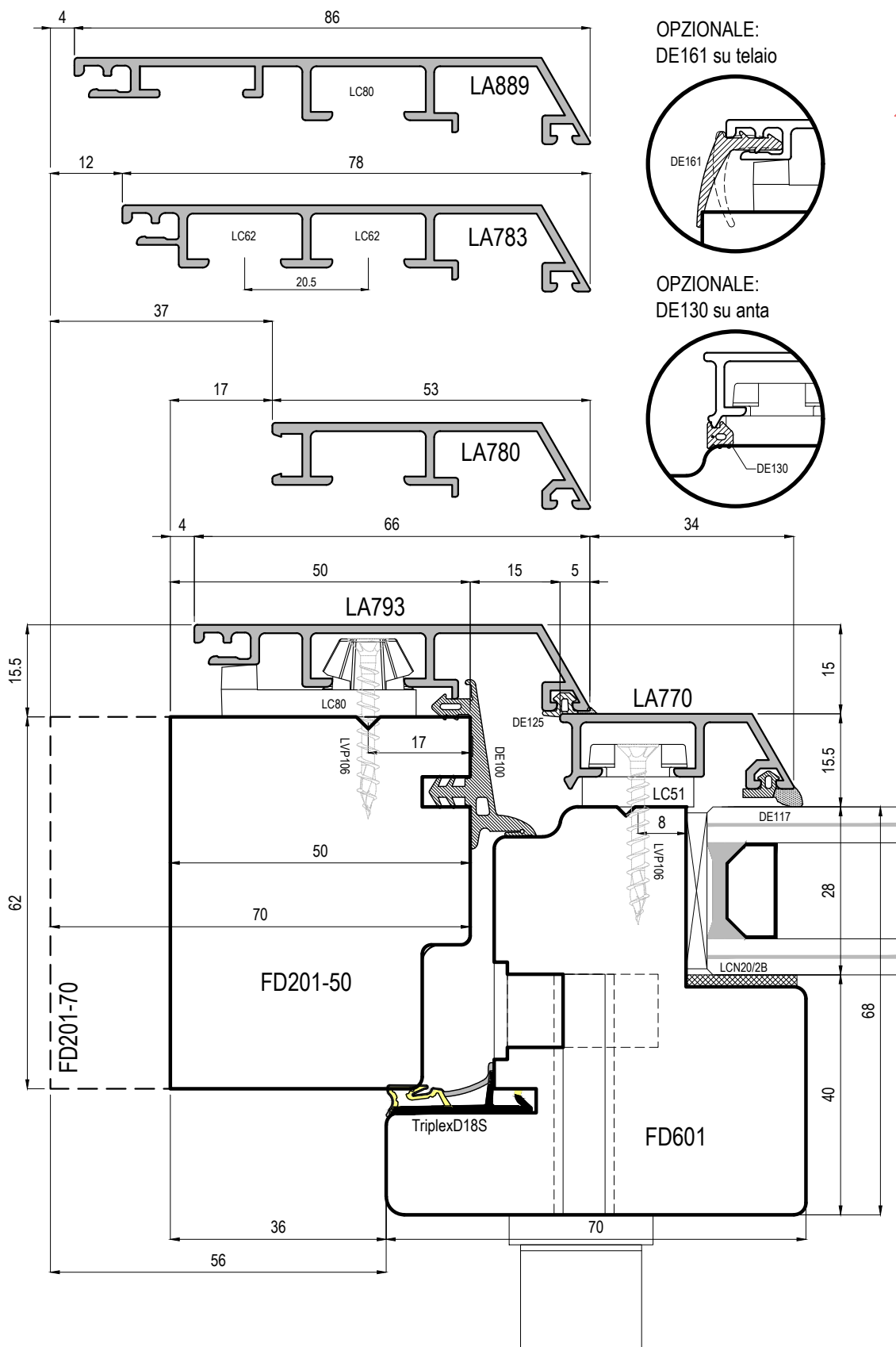

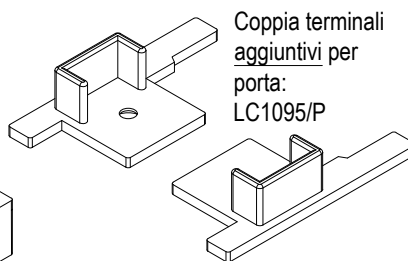
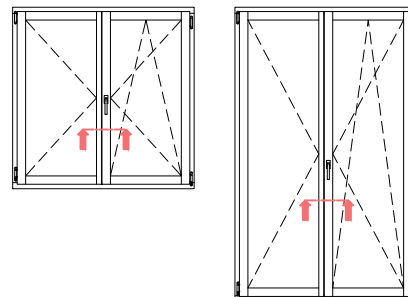
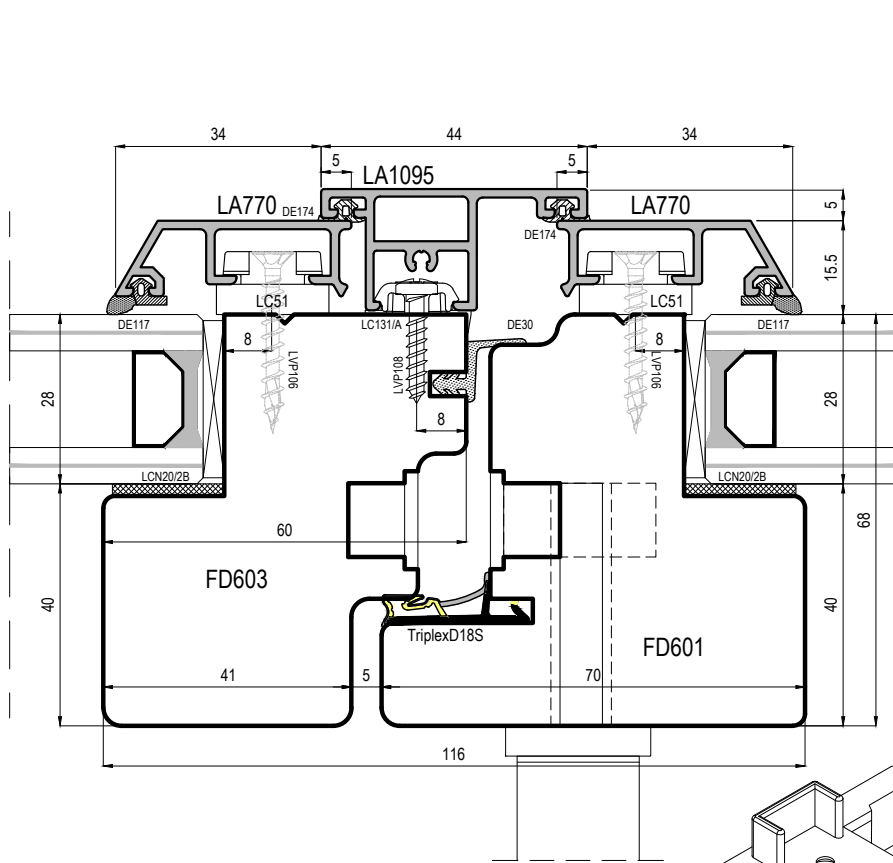

Coppia terminali aggiuntivi per porta: LC1095/P

Coppia terminali LC1095

Sezione chiusura centrale porta

IMPORTANTE: Fissare il terminale superiore per bloccare lo scorrimento del profilo LA1095

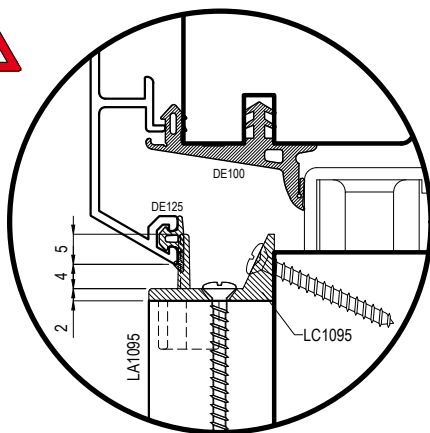
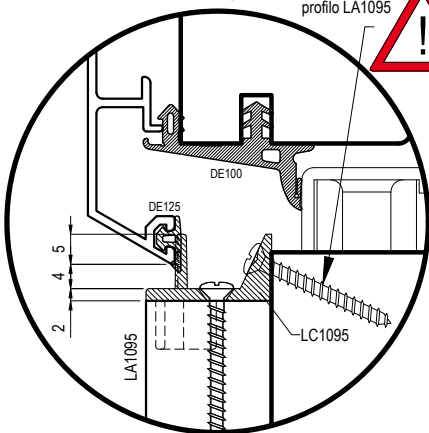

Sezione chiusura centrale finestra

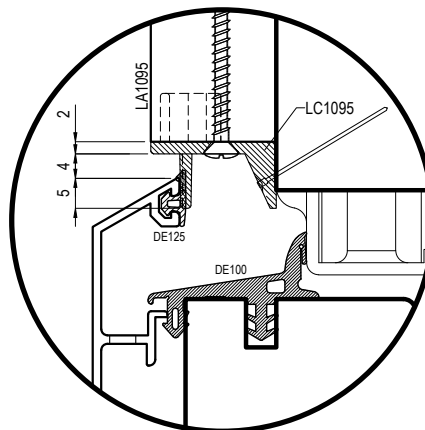
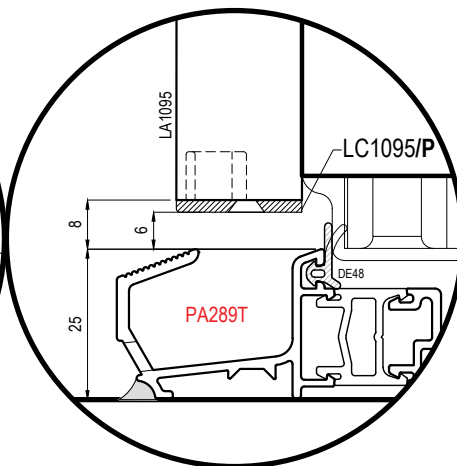
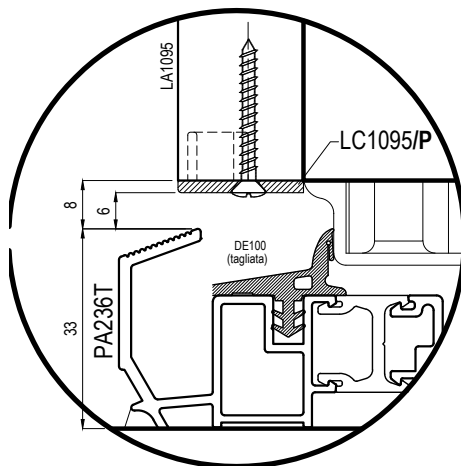
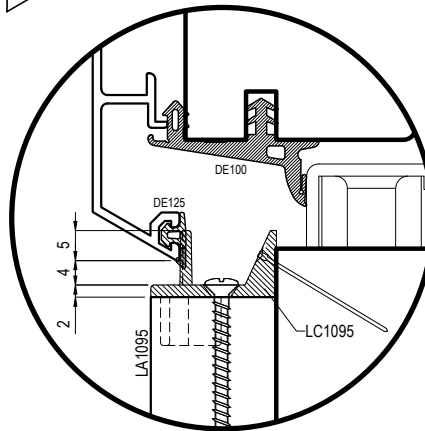

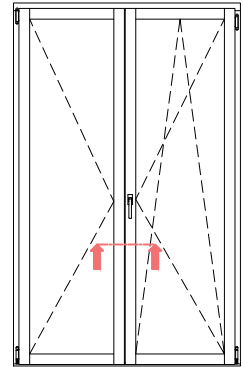
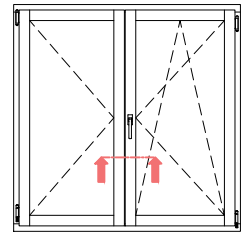
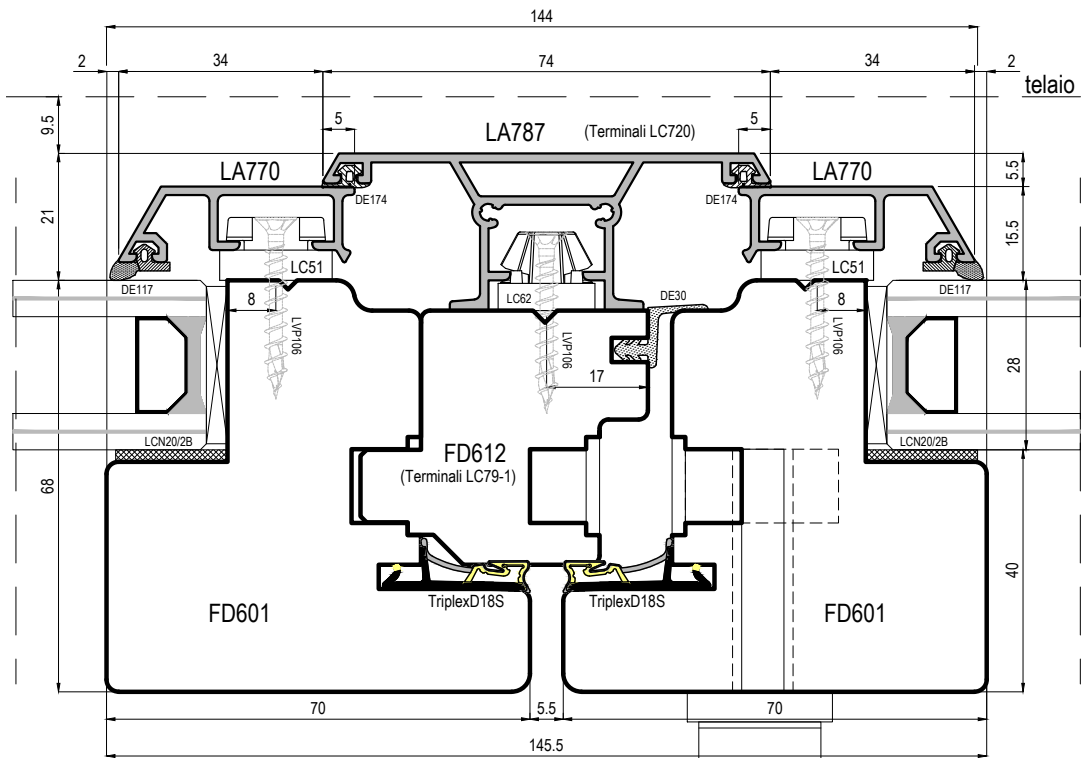

Sezione chiusura centrale porta  **IMPORTANTE:** Fissare il terminale superiore per bloccare lo scorrimento del profilo

Sezione chiusura centrale finestra

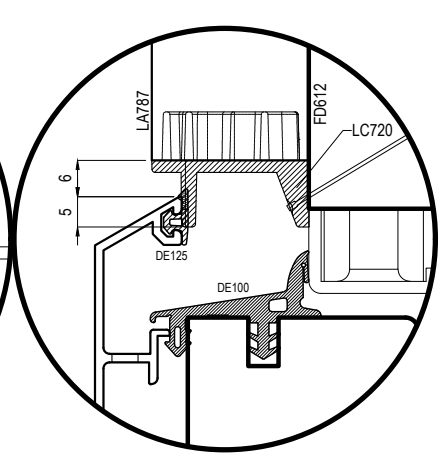
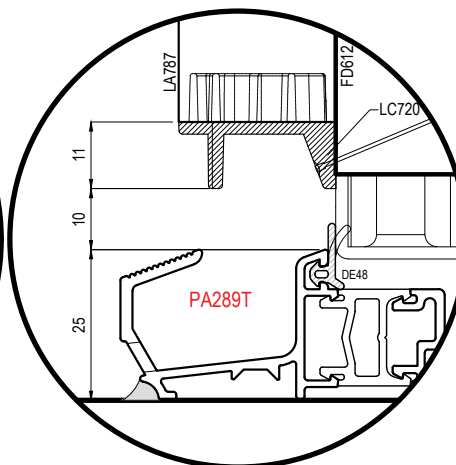
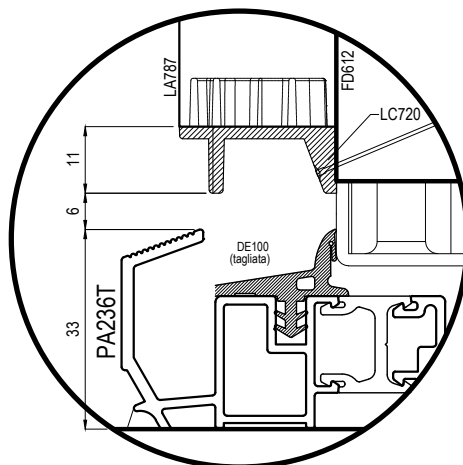
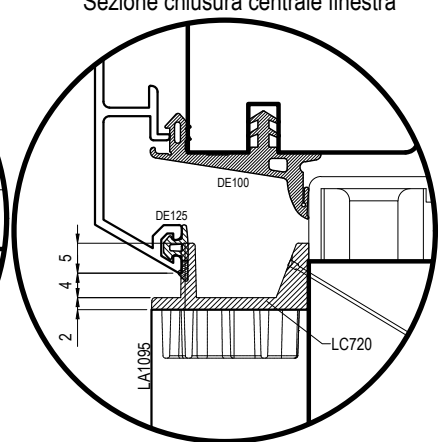
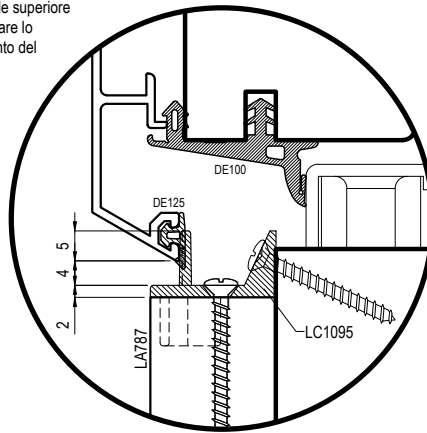
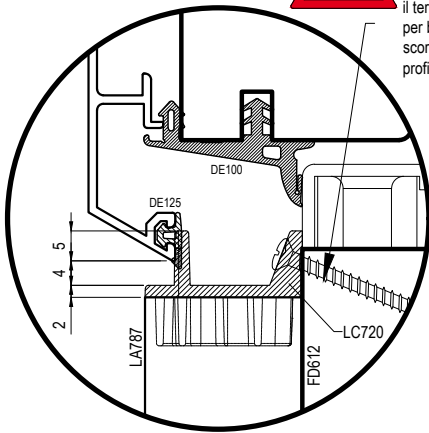

uni_one - Sistema Standard

Scala 0.8:1

Produced with:
uni_one
TECHNOLOGY

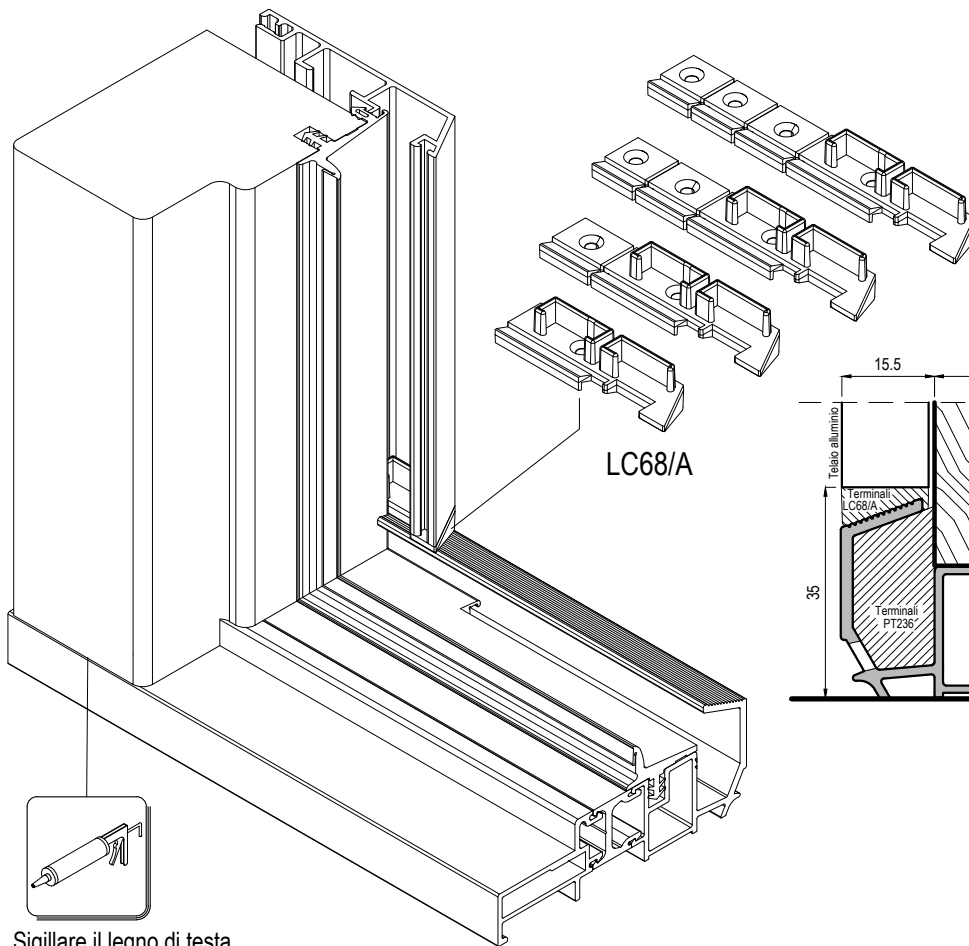

Alluminio	Accessorio
LA780	LC68/A tagliato
LA793	LC68/A tagliato
LA783	LC68/A tagliato
LA889	LC68/A

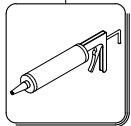
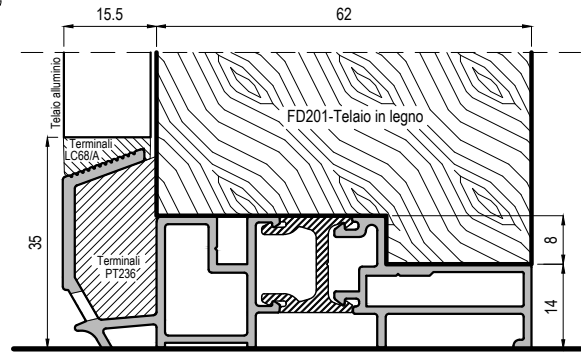

Sigillare il legno di testa

Misure di taglio e posizionamento profilo LA742

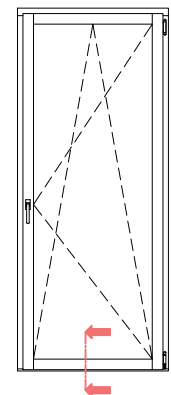
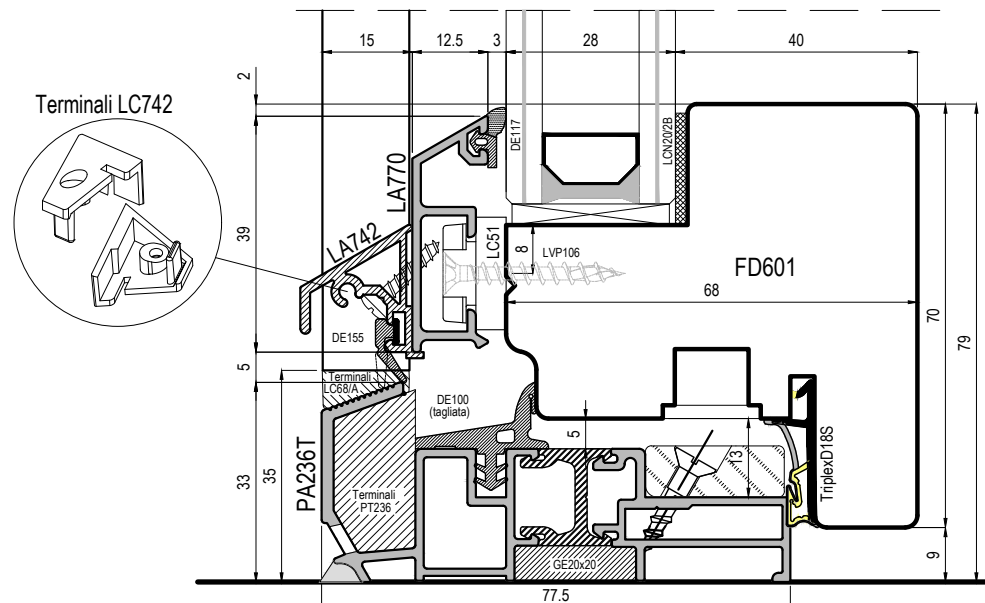
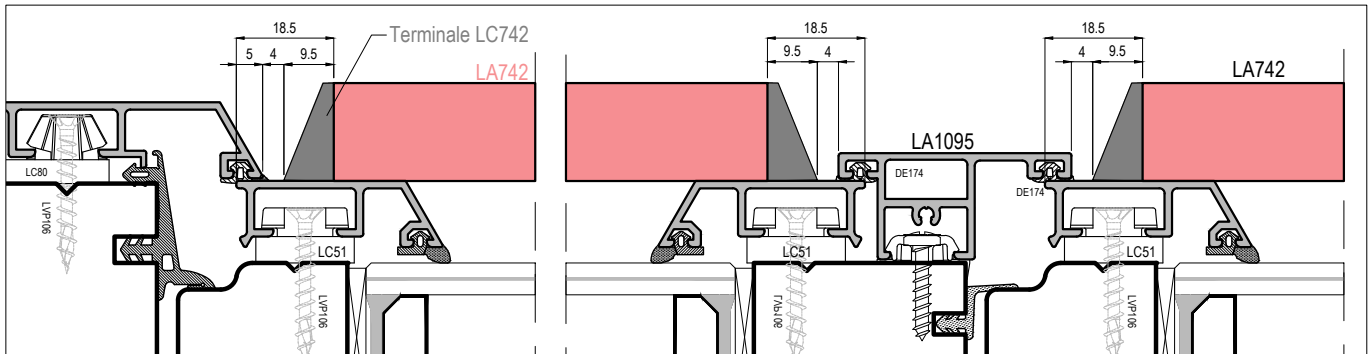

uni_one - Sistema Standard

Scala 0.8:1

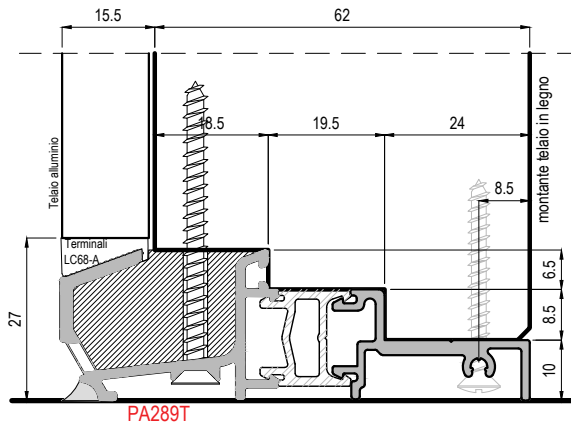
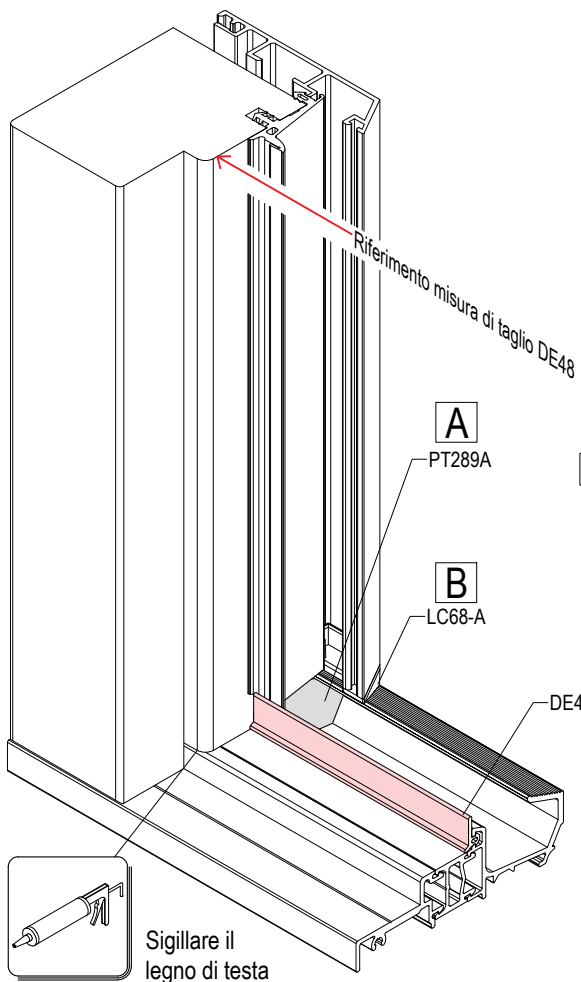

Conforme alla normativa per l'abbattimento delle barriere architettoniche BARRIER FREE

A			B	
Telaio	Accessorio	Misura	Alluminio	Accessorio
FD201-50	PT289A-50	50mm	LA780	LC68/A tagliato
FD201-70	PT289A-70	70mm	LA793	LC68/A tagliato
FD305	PT289A-38	38mm	LA783	LC68/A tagliato
FD312	PT289A-33	33mm	LA889	LC68/A
FD104	PT289A-70	70mm		

Misure di taglio e posizionamento profilo LA742

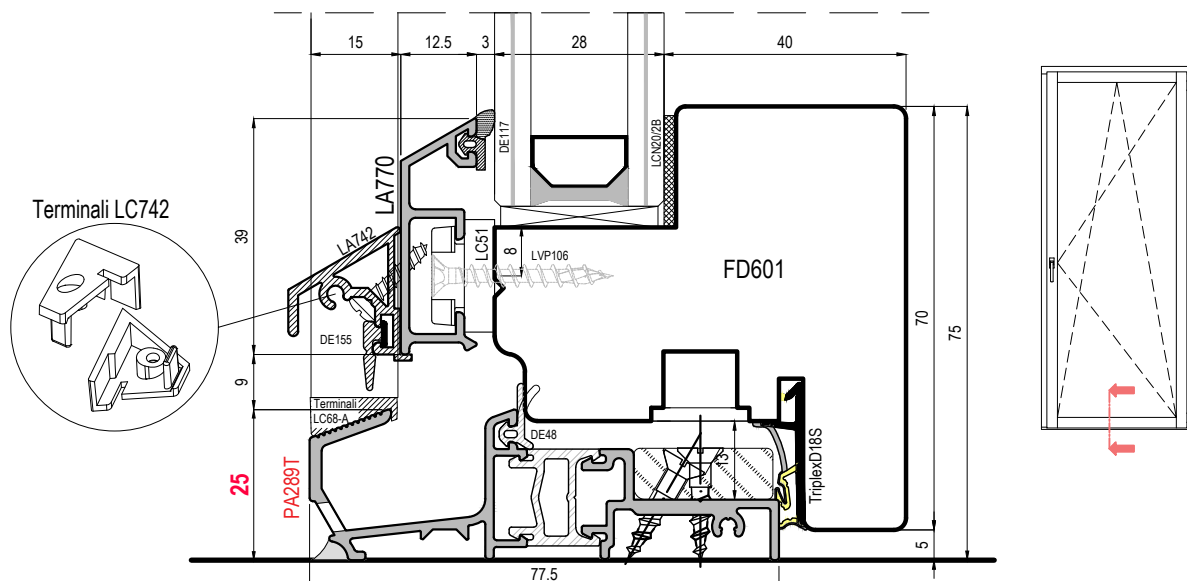
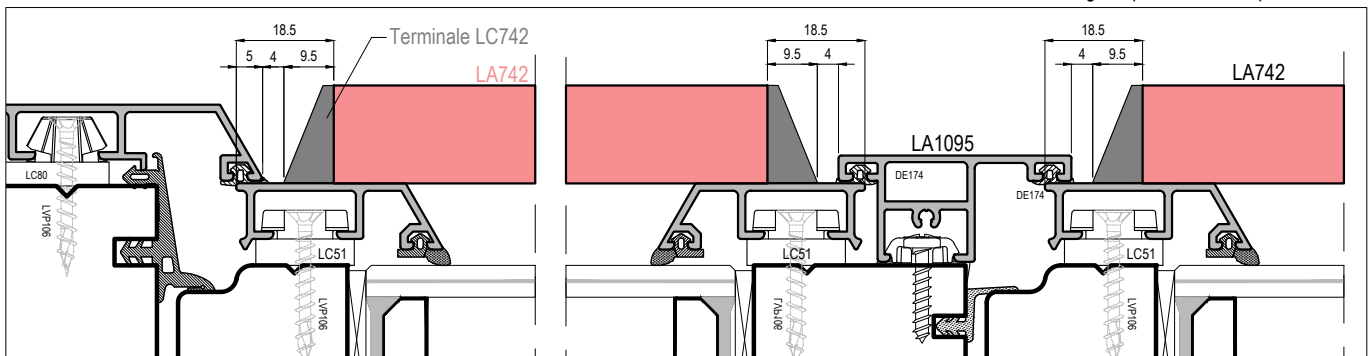

uni_one - Sistema Standard

Scala 0.8:1



Conforme alla
normativa per
l'abbattimento
delle barriere
architettoniche
BARRIER FREE

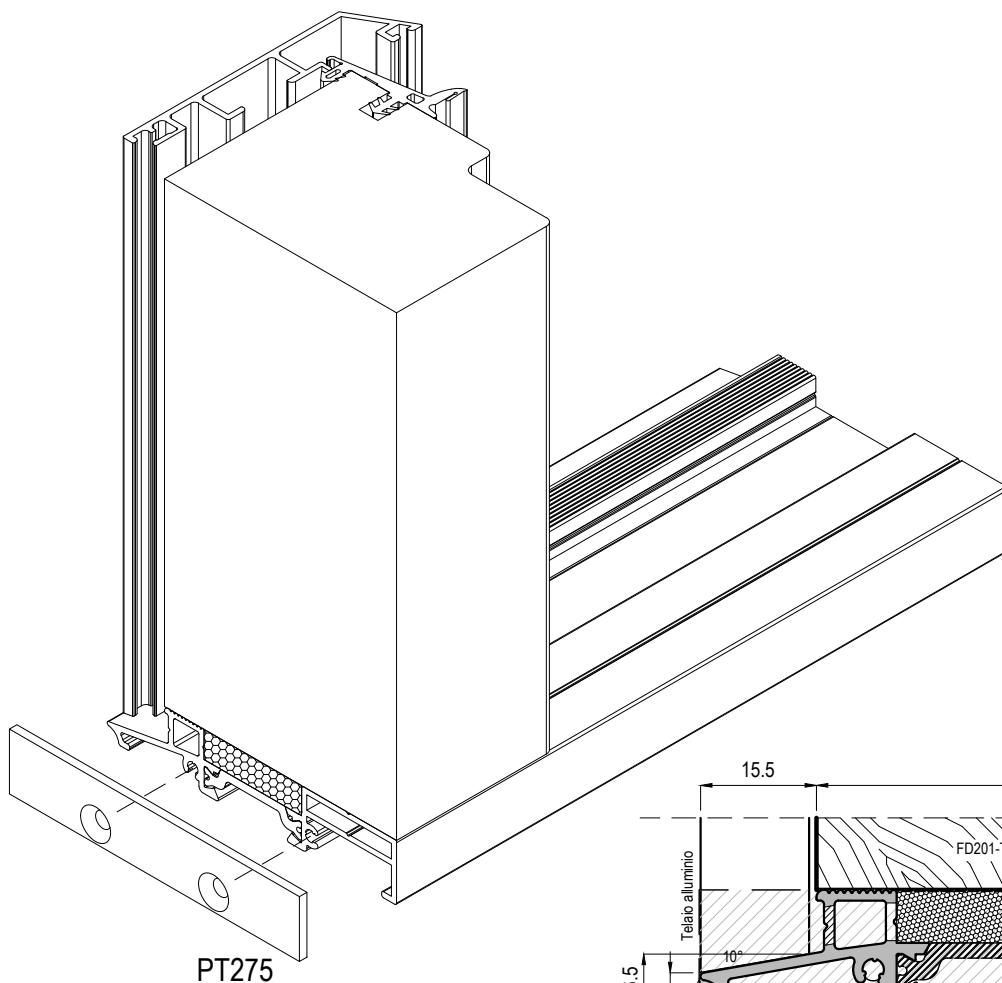

PT275

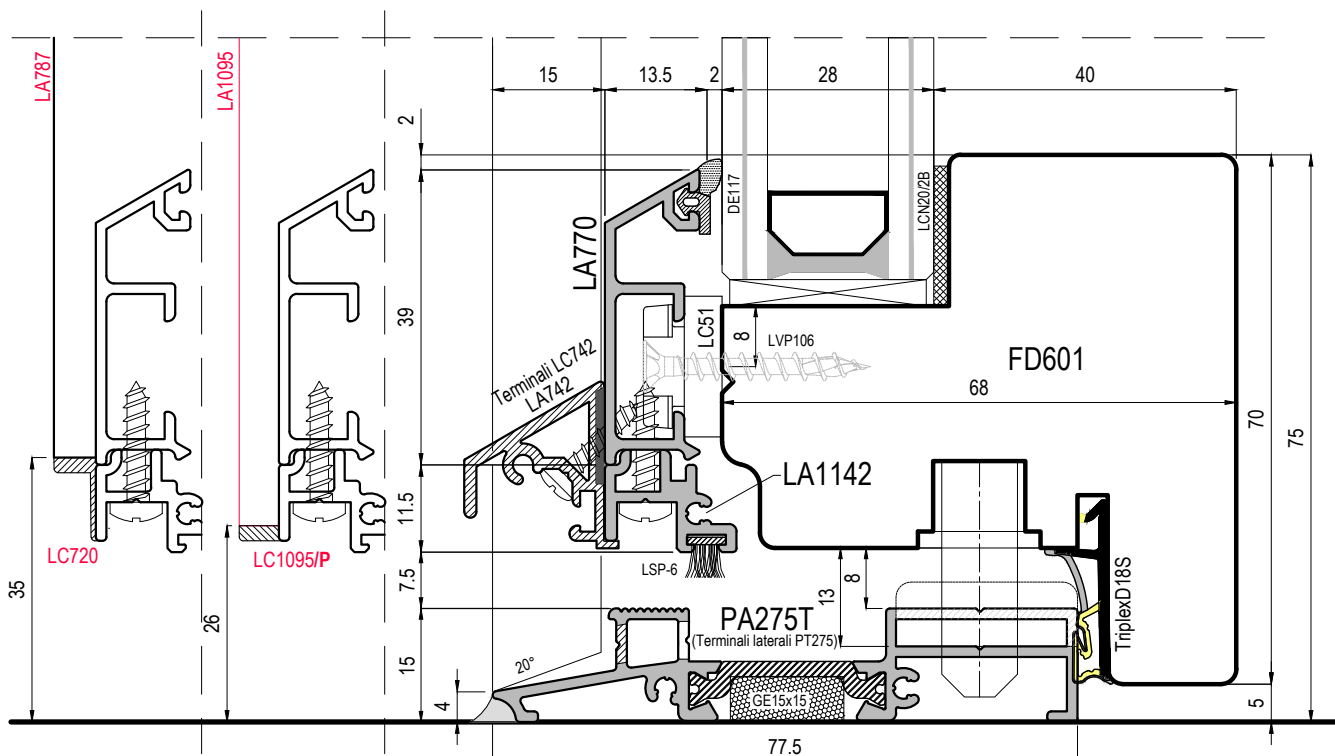
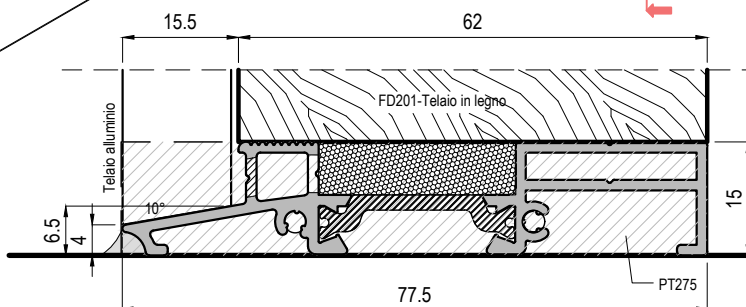
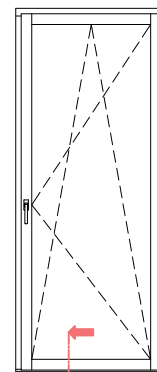

uni_one - Sistema Standard

Scala 1:1

Produced with:
uni_one
TECHNOLOGY



Conforme alla
normativa per
l'abbattimento
delle barriere
architettoniche
BARRIER FREE

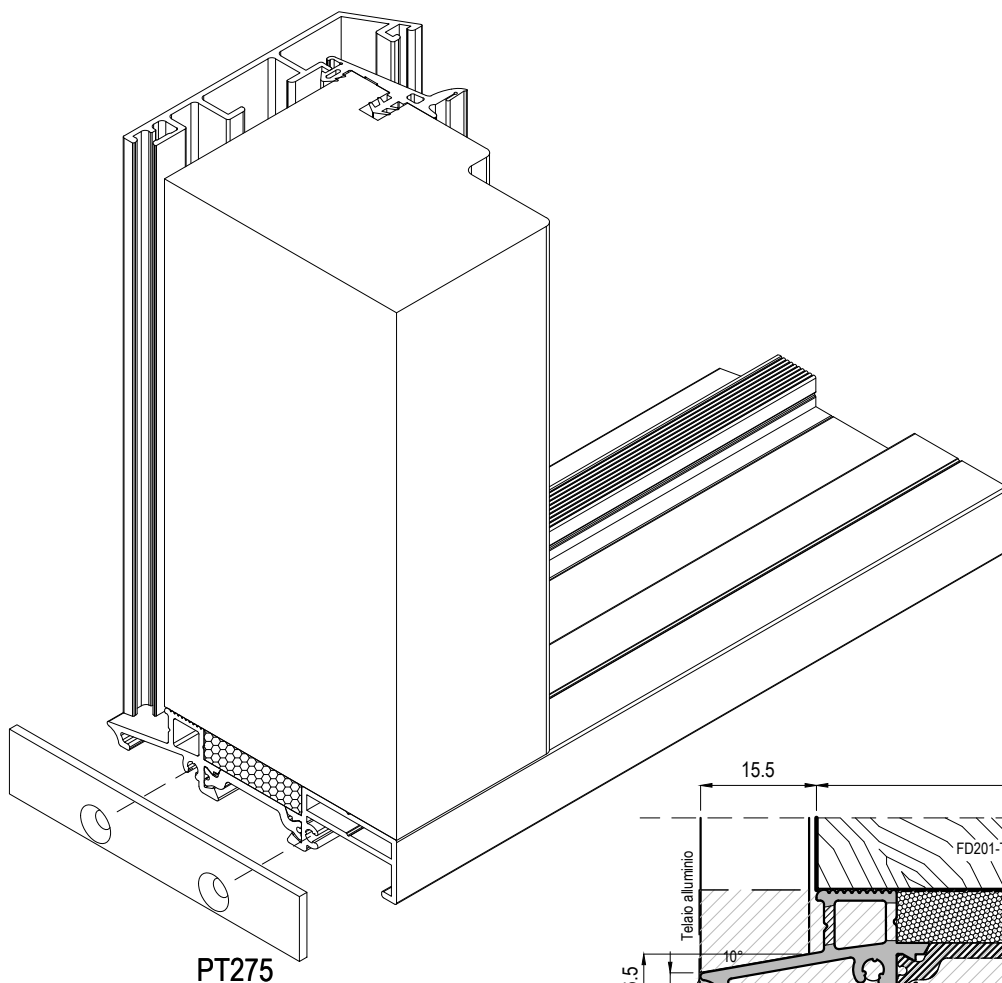

PT275

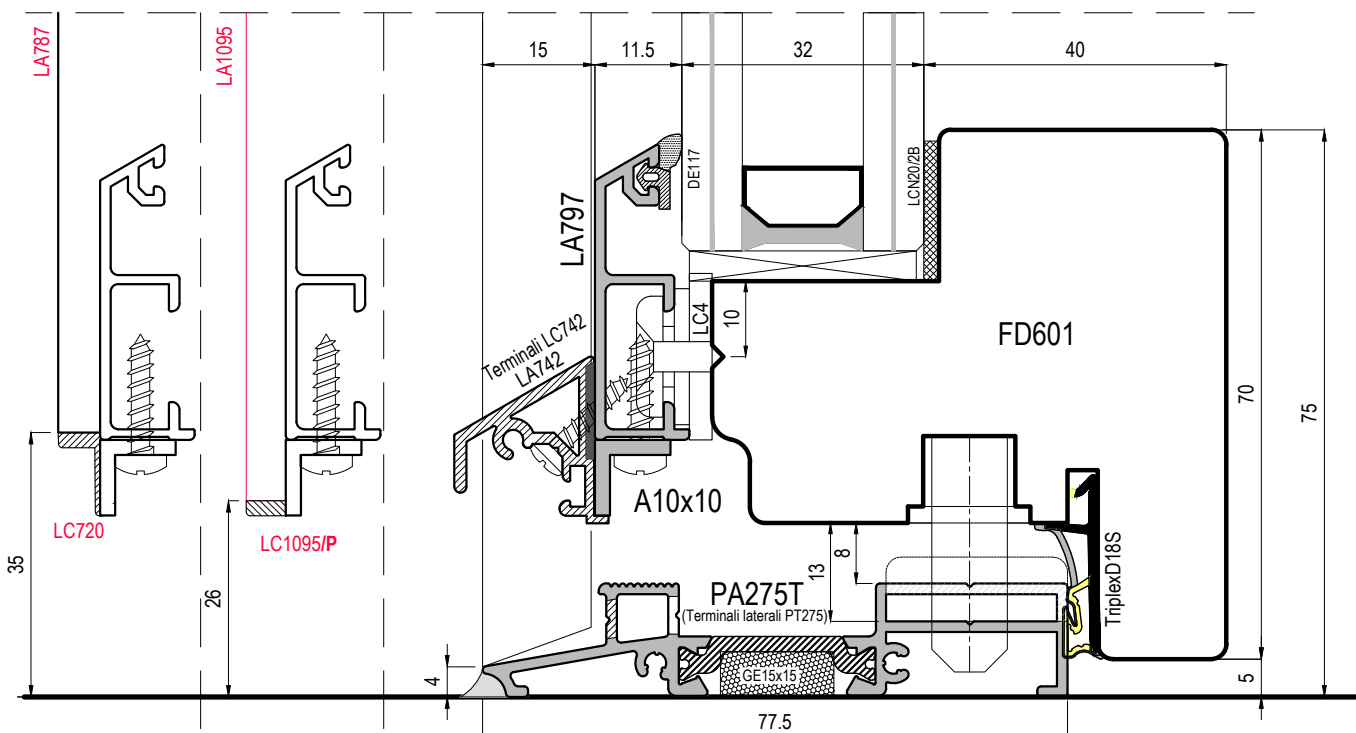
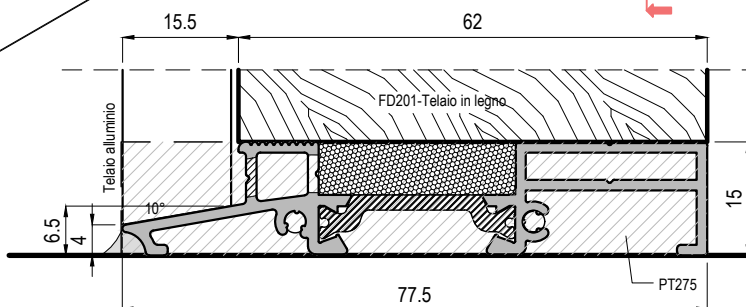
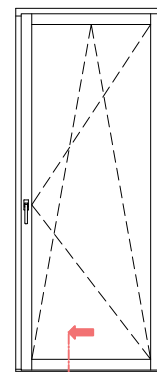

uni_one - Sistema Standard

Scala 1:1

CT_uni_one Standard-ver.00/02.24

Produced with:
uni_one
TECHNOLOGY



Soluzione non coperta
da Cascading

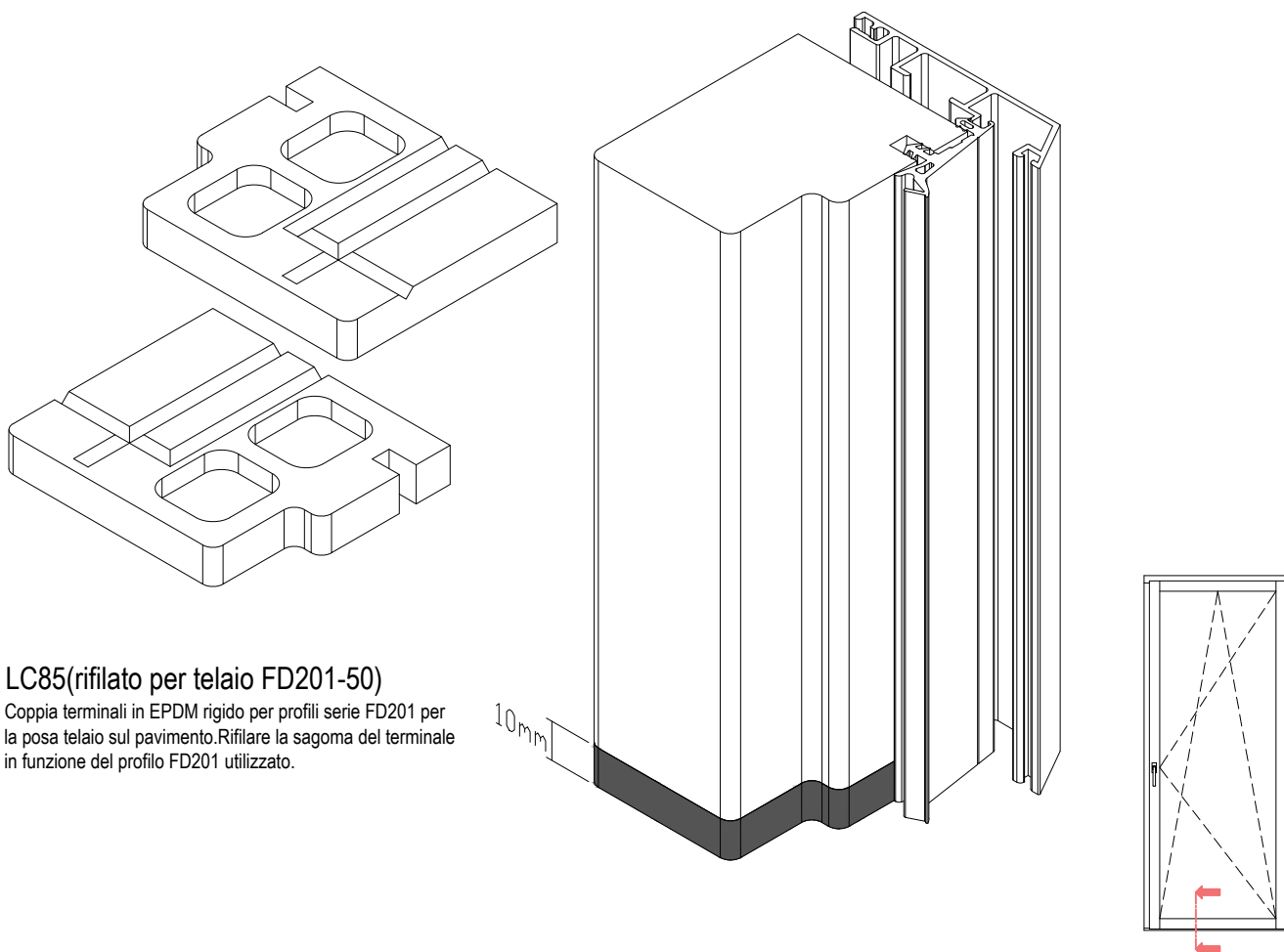

LC85(rifilato per telaio FD201-50)

Coppia terminali in EPDM rigido per profili serie FD201 per la posa telaio sul pavimento. Rifilare la sagoma del terminale in funzione del profilo FD201 utilizzato.

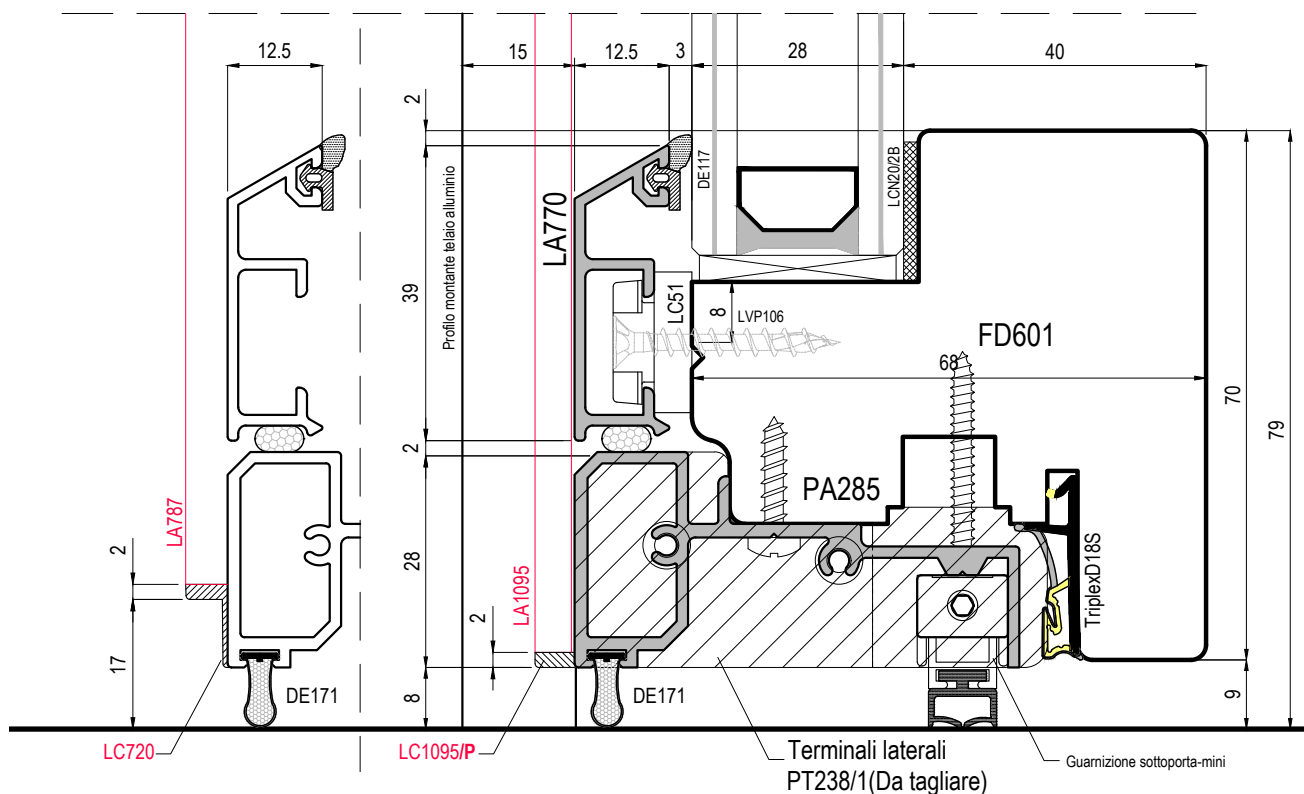

uni_one - Sistema Standard

Scala 1:1

CT_uni_one Standard-ver.00/02.24

Produced with:
uni_one
TECHNOLOGY

Variante per vetro sp.32mm
(non utilizzabile in combinazione con LA1083)

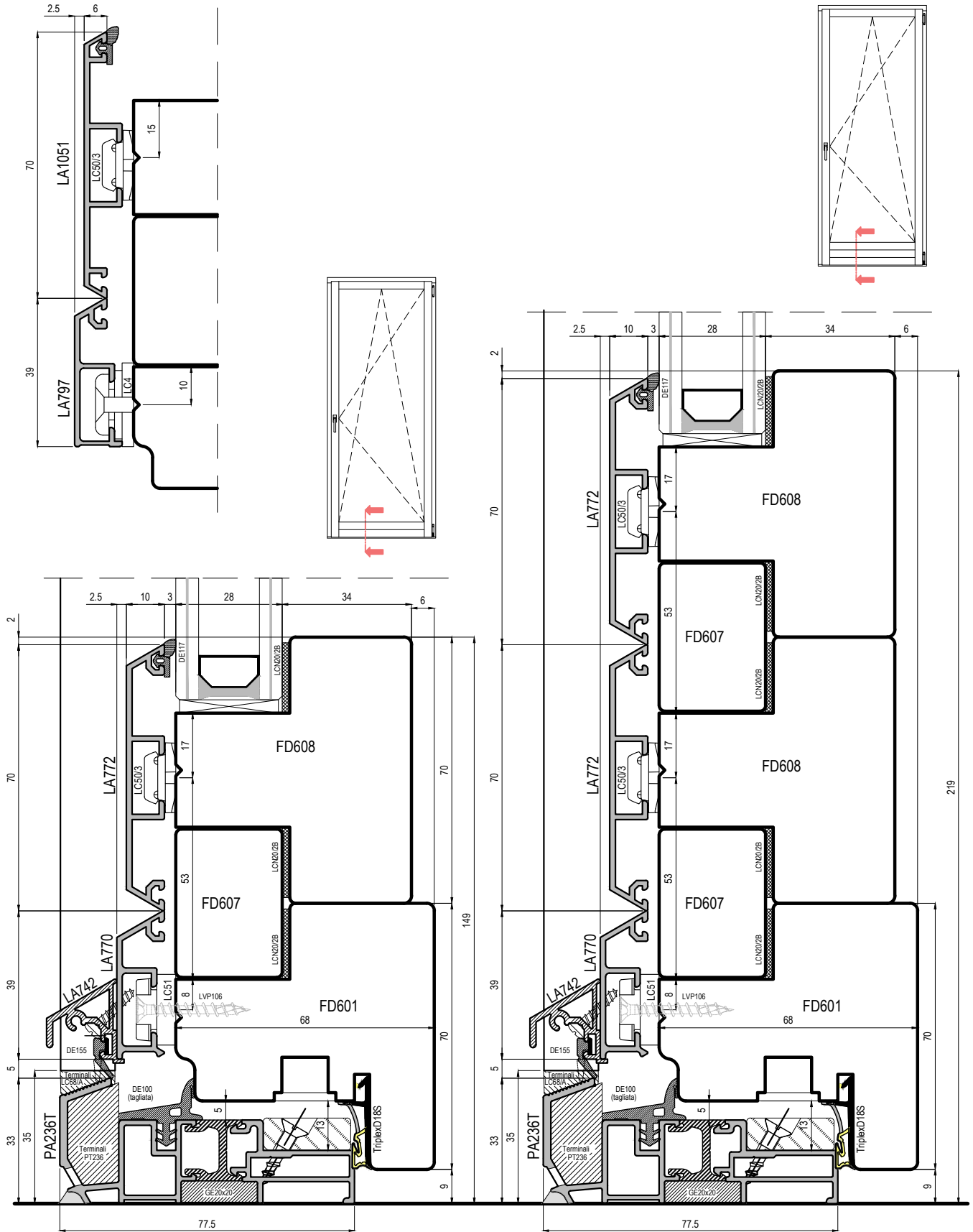

uni_one - Sistema Standard

Scala 0.7:1

Produced with:
uni_one
TECHNOLOGY

CT_uni_one Standard-ver.00/02.24

Variante per vetro sp.32mm
(non utilizzabile in combinazione con LA1083)



Conforme alla normativa per l'abbattimento delle barriere architettoniche BARRIER FREE

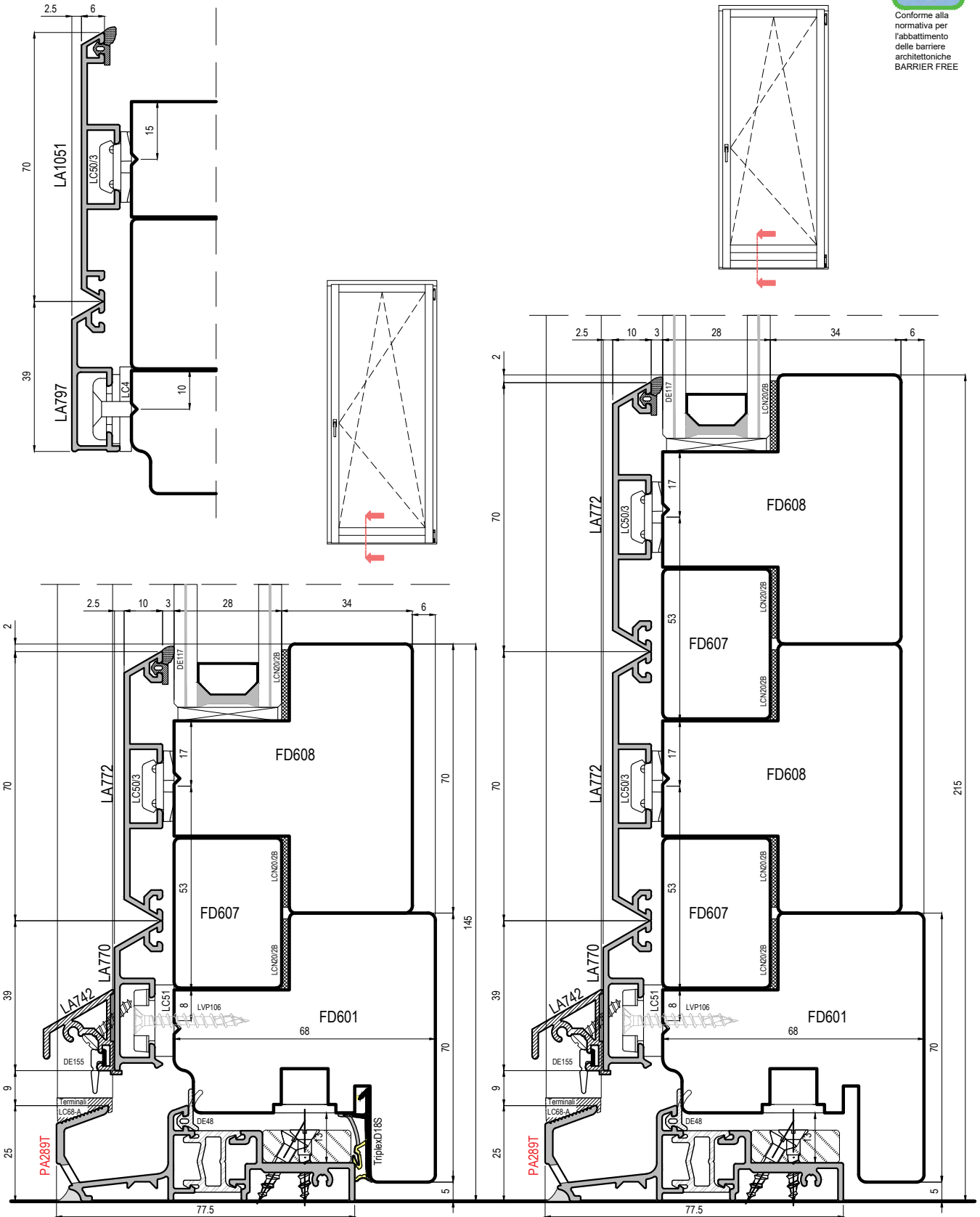

uni_one - Sistema Standard

Scala 0.7:1

CT_uni_one Standard-ver.00/02.24

Produced with:
uni_one
TECHNOLOGY

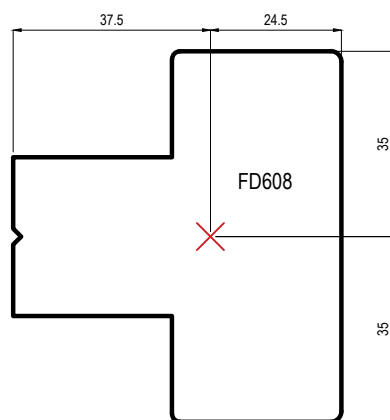
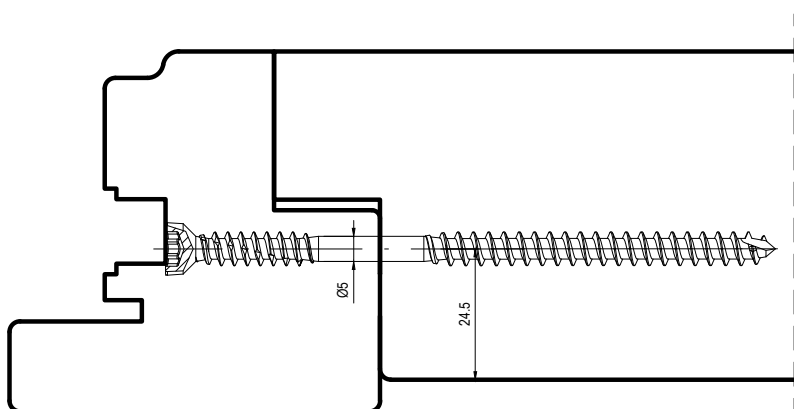
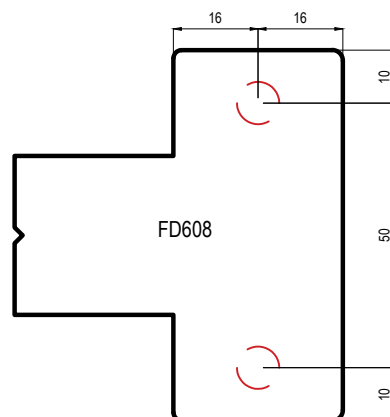
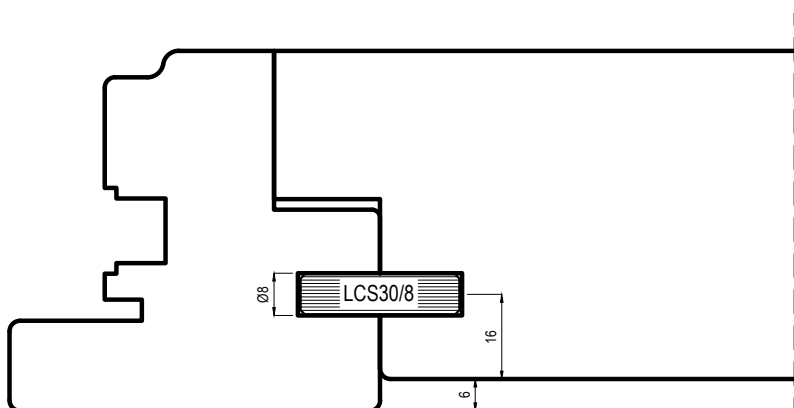
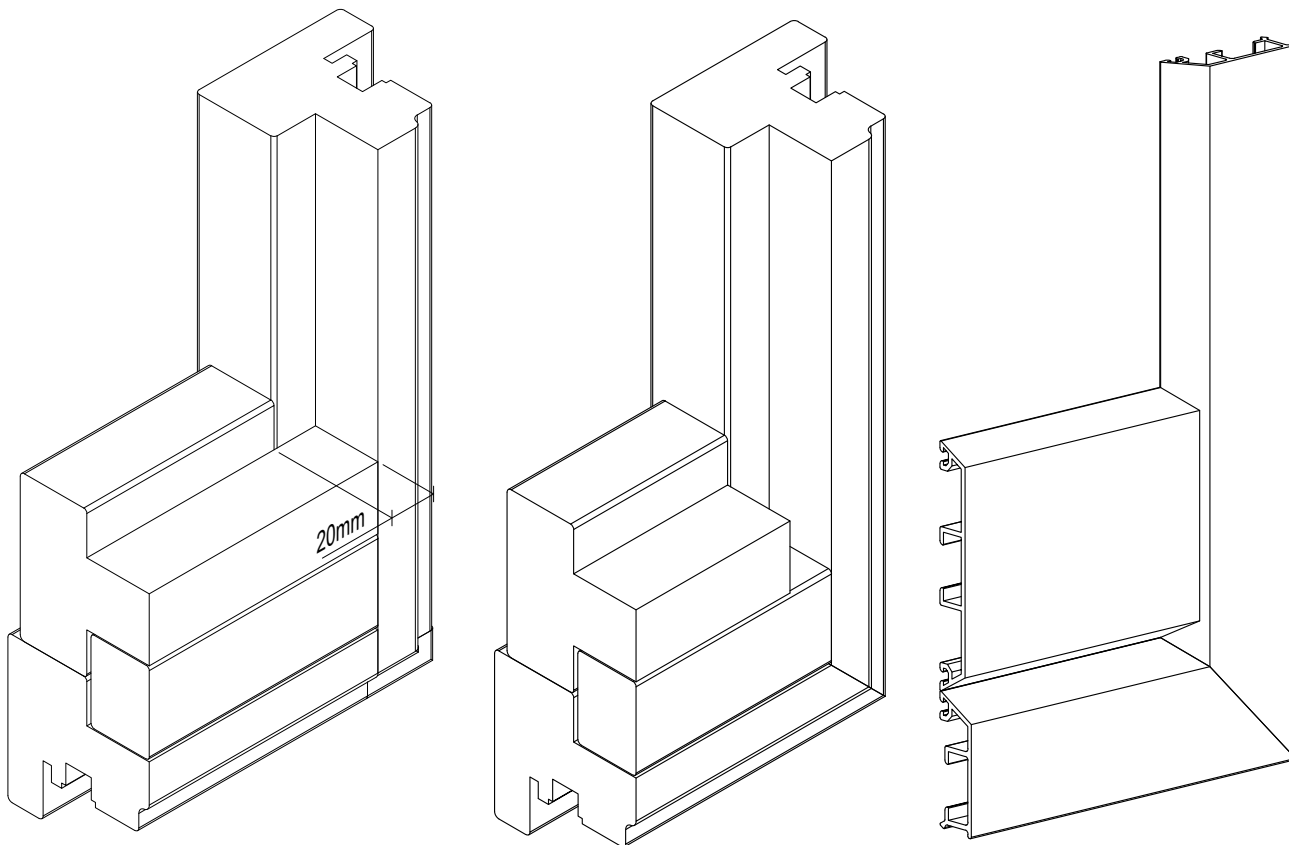

Variante per vetro sp.32mm
(non utilizzabile in combinazione con LA1083)

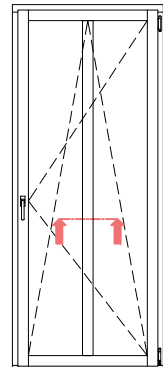
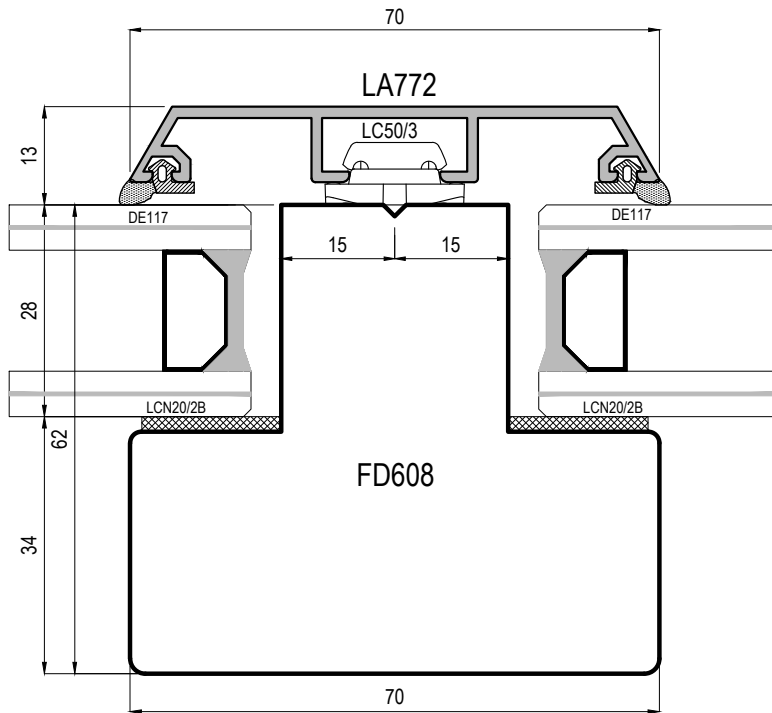
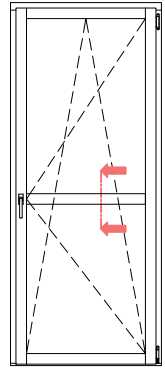
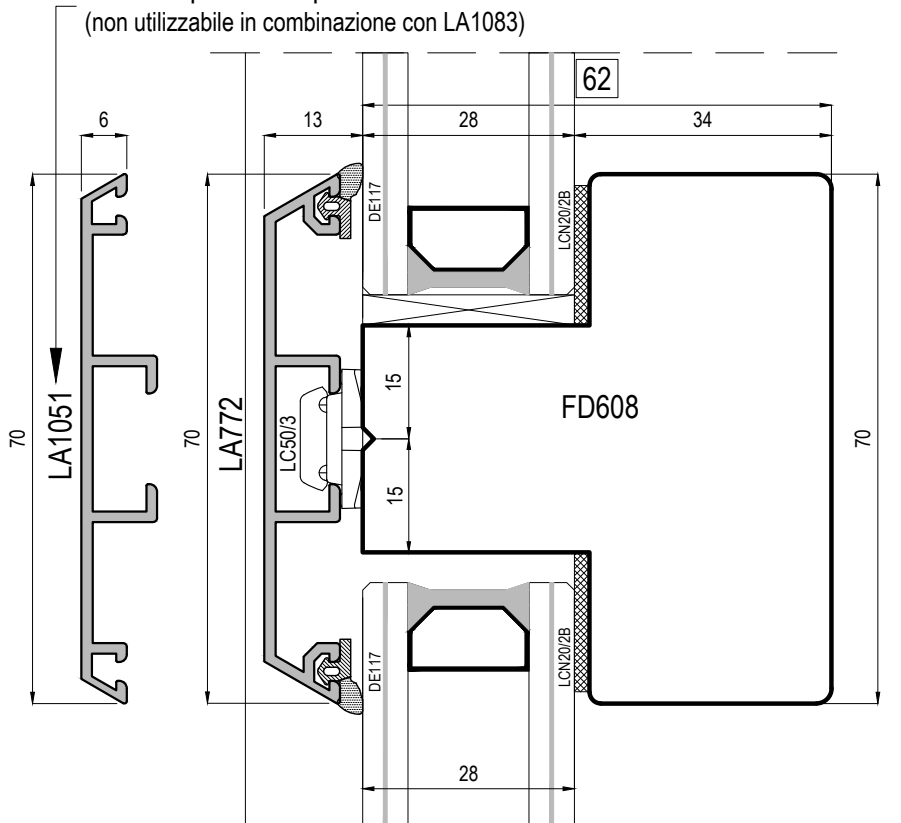

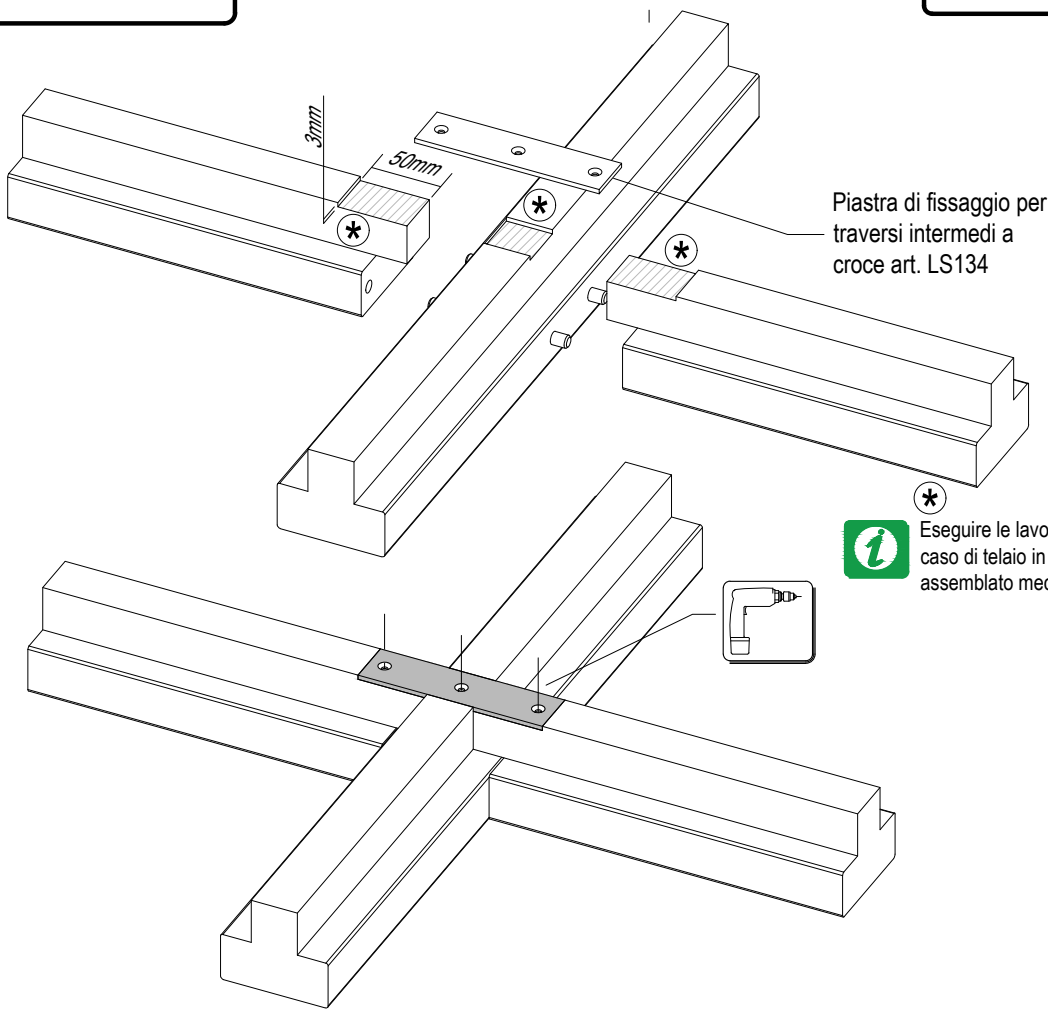
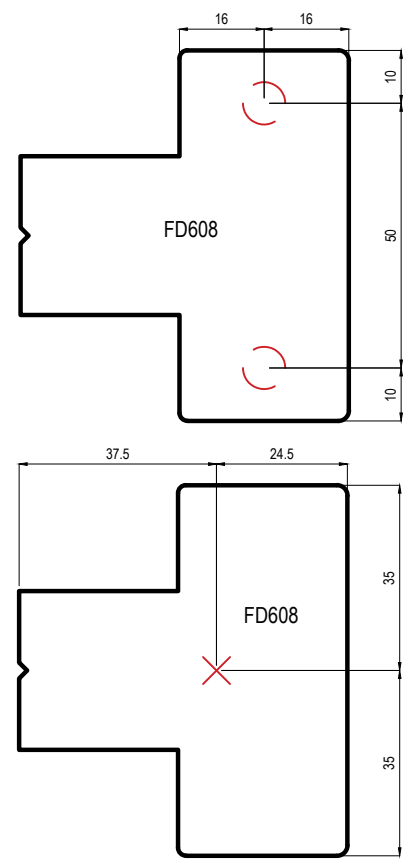
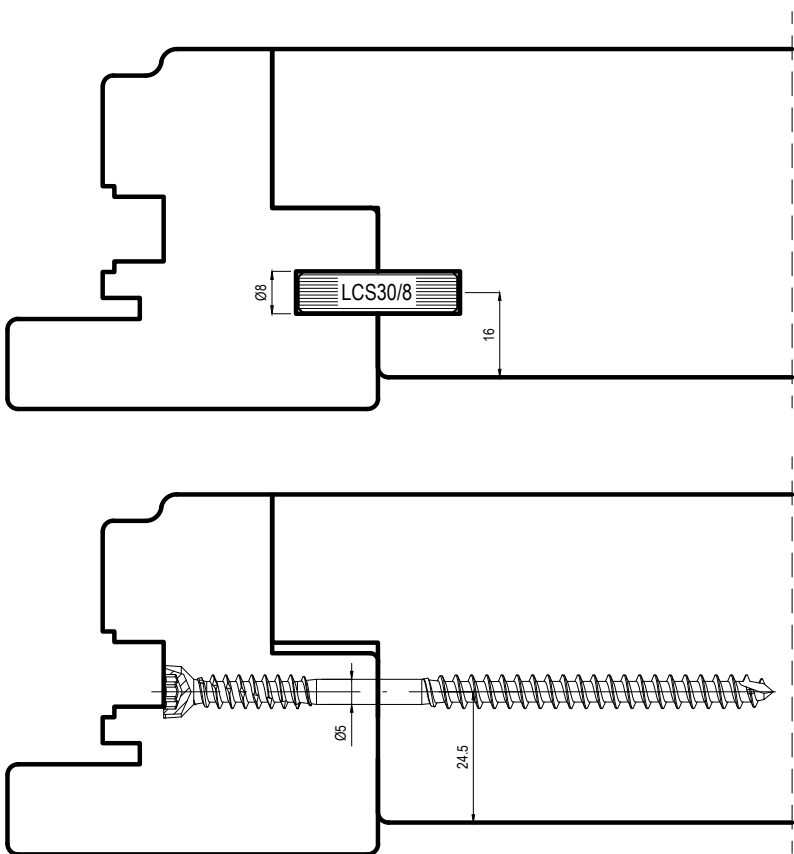

 Eseguire le lavorazioni solo nel caso di telaio in alluminio assemblato meccanicamente

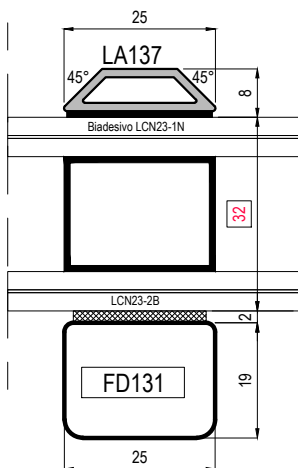
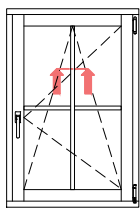
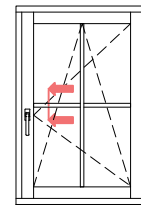
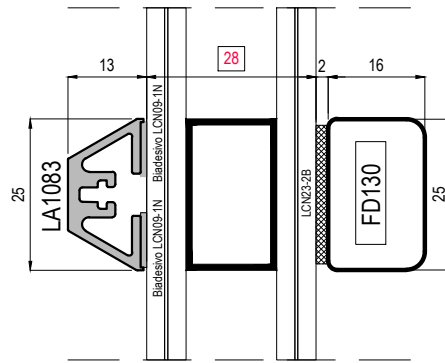
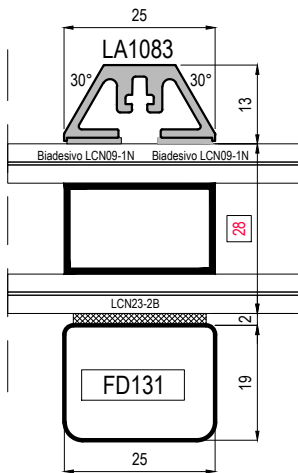
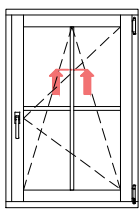

I profili in alluminio LA137 vengono forniti tagliati a misura. Non disponibile nella versione assemblata o saldata all'anta
 LA137 aluminium profiles are supplied cut to size. Not available in the assembled or welded version

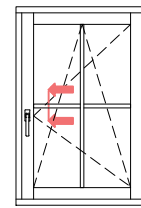
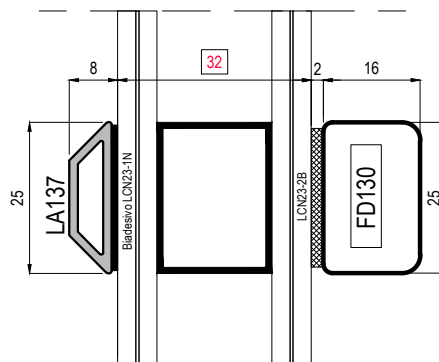

ISTRUZIONI PER IL MONTAGGIO DEI PROFILI INGLESINA:

1. Pulizia della superficie del vetro e dell'alluminio con alcool isopropilico LCALCOL-IP
2. Applicazione del LCPRIMER86 sui profili inglesina in alluminio
3. Attendere alcuni minuti per la completa asciugatura del prodotto ed applicare il nastro biadesivo sui profili
4. Rimuovere parte del biadesivo dalla parte centrale e applicare la colla LC-PUB600E(vedi schema 4.1)
5. Bagnare la superficie del vetro con alcol isopropilico: questa operazione permette al nastro biadesivo di incollarsi correttamente senza la formazione di bolle d'aria
6. Applicare i profili sprossen o il telaio prima dell'evaporazione dell'alcol dalla superficie del vetro. Esercitare un'adeguata pressione per fare aderire correttamente il biadesivo al vetro
7. Tenere l'anta in posizione orizzontale con l'applicazione di un peso soprattutto negli incroci tra inglesine per favorire il corretto incollaggio
8. Attendere almeno 2 ore prima della rimozione dei pesi e l'installazione dell'anta

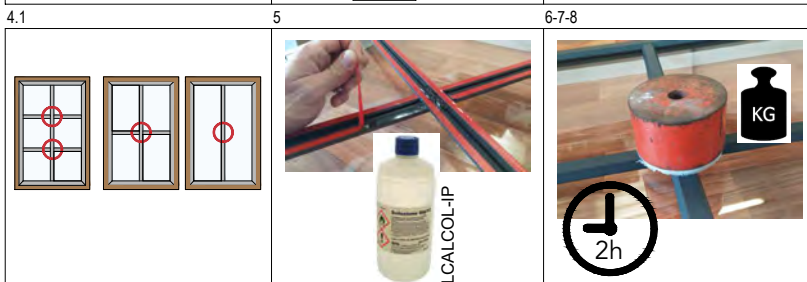
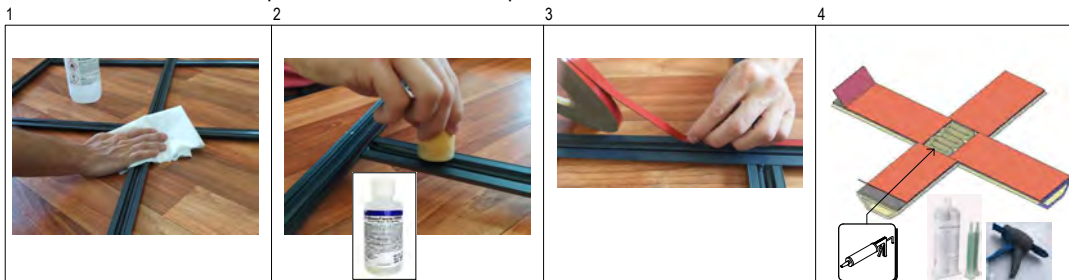

Per maggiori dettagli:
<http://www.uniform.it/prodotti/systems/profil-traversi-intermedi-anta/>

uni_one - Sistema Standard

Scala 0.8:1

CT uni_one Standard-ver.00/02.24

Produced with:
uni_one
 TECHNOLOGY

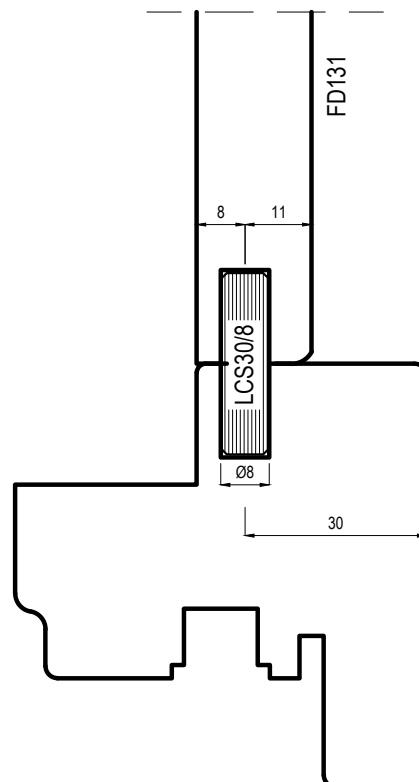
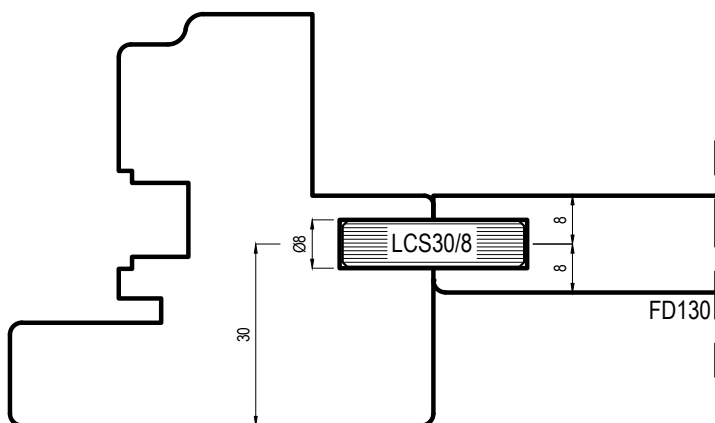

Assemblaggio con graffe
metalliche (Lungh. max=15mm)
tra i traversi FD130 e FD131

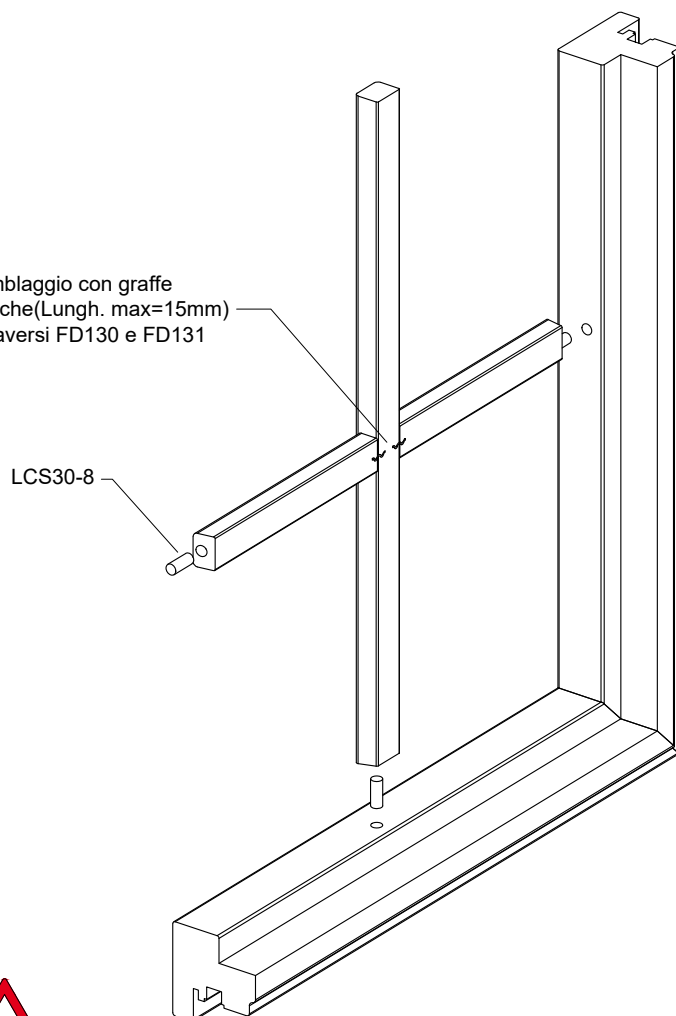

Istruzioni per il corretto incollaggio dei profili inglesina al vetro:

- 1) Nel caso il nastro biadesivo non fosse già premontato sul profilo in legno, è sufficiente pulire la parte in legno eliminando tracce di polveri o altri residui prima dell'applicazione
- 2) Pulizia della superficie del vetro con alcool isopropilico
- 3) Spruzzare leggermente il vetro con alcool isopropilico nella zona di contatto con il biadesivo. Ciò permette successivamente di evitare la formazione di bolle d'aria tra il nastro ed il vetro
- 4) Rimozione della pellicola protettiva del biadesivo e fissaggio al vetro. Applicare una pressione adeguata in modo da fare aderire tutta la superficie del nastro al vetro fino all'"asciugatura" e completa adesivizzazione dello stesso.

NOTE: la temperatura ideale per l'applicazione del nastro biadesivo è da 20 a 38° C. L'applicazione al di sotto dei 10° C è sconsigliata poiché l'adesivo risulta troppo rigido per aderire in modo appropriato.

Per maggiori dettagli:

uni_one - Sistema Standard

Scala 0.8:1

CT uni_one Standard-ver.00/02.24

Produced with:

uni_one
TECHNOLOGY

Variante profilo anta per vetro sp.32mm

OPZIONALE:
DE130 su anta

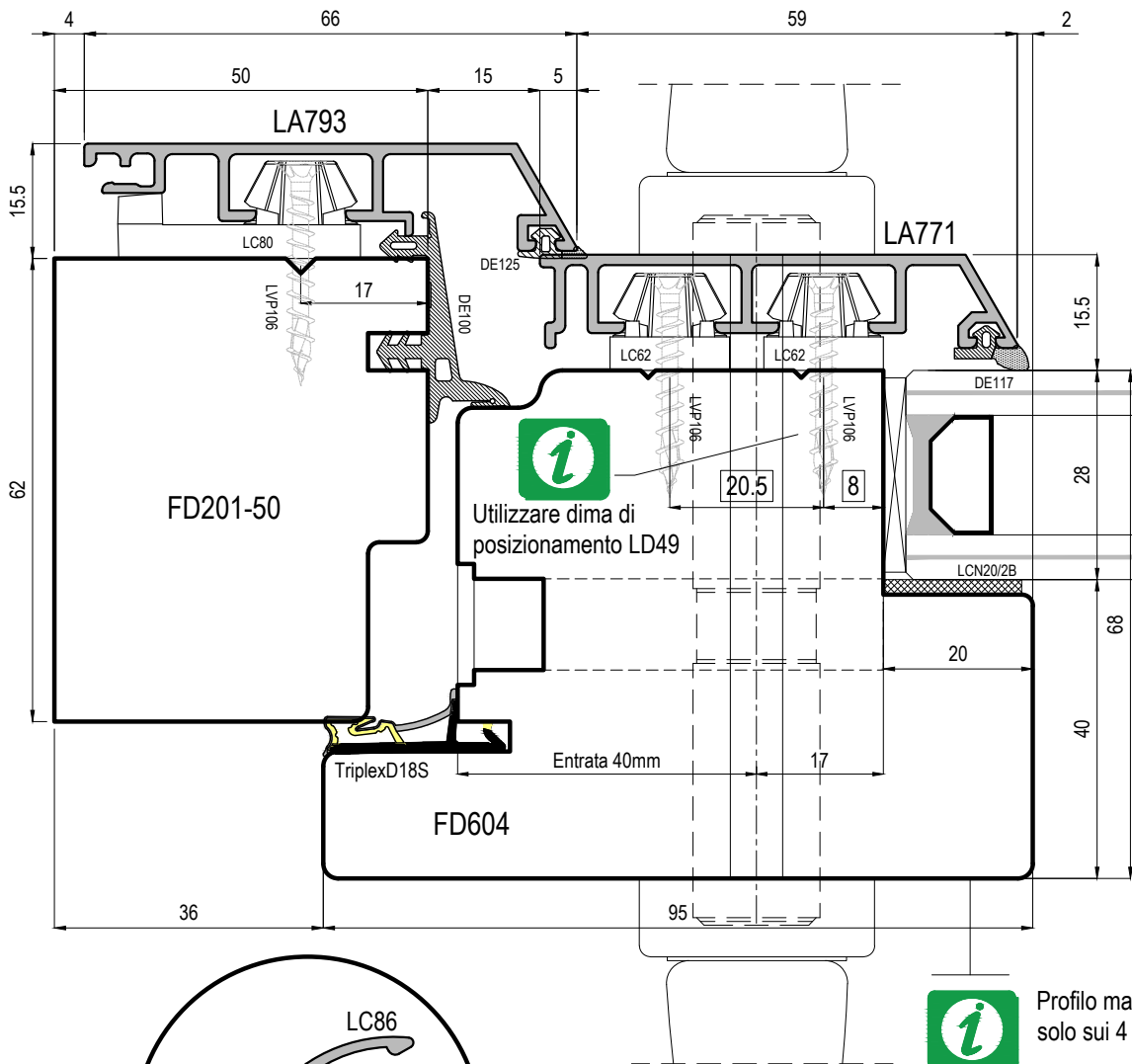
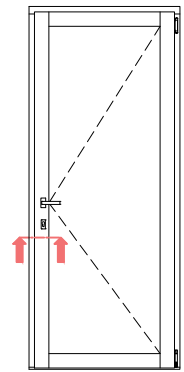
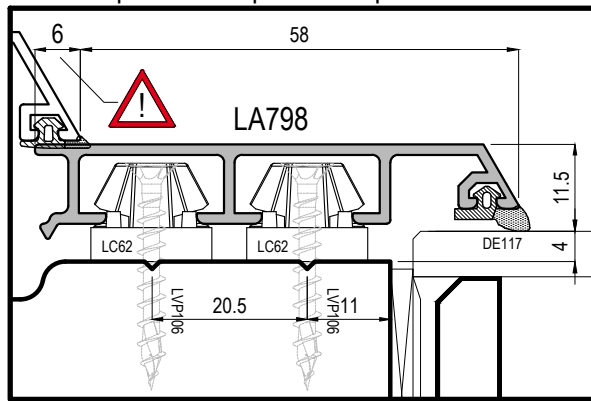
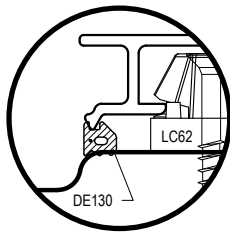

Utilizzare dima di
posizionamento LD49



Profilo maggiorato utilizzabile
solo sui 4 lati anta

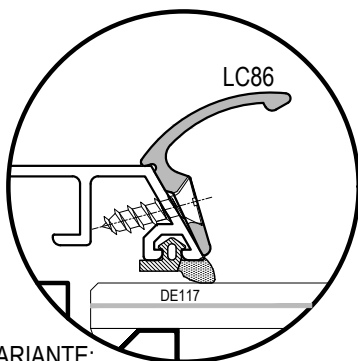

VARIANTE:
Maniglia fissa esterna LC86

Su richiesta
On request

Maniglia fissa esterna **LC86**
Finiture disponibili:
Bronzo chiaro, Testa di
Moro, Argento, Bianco 9016

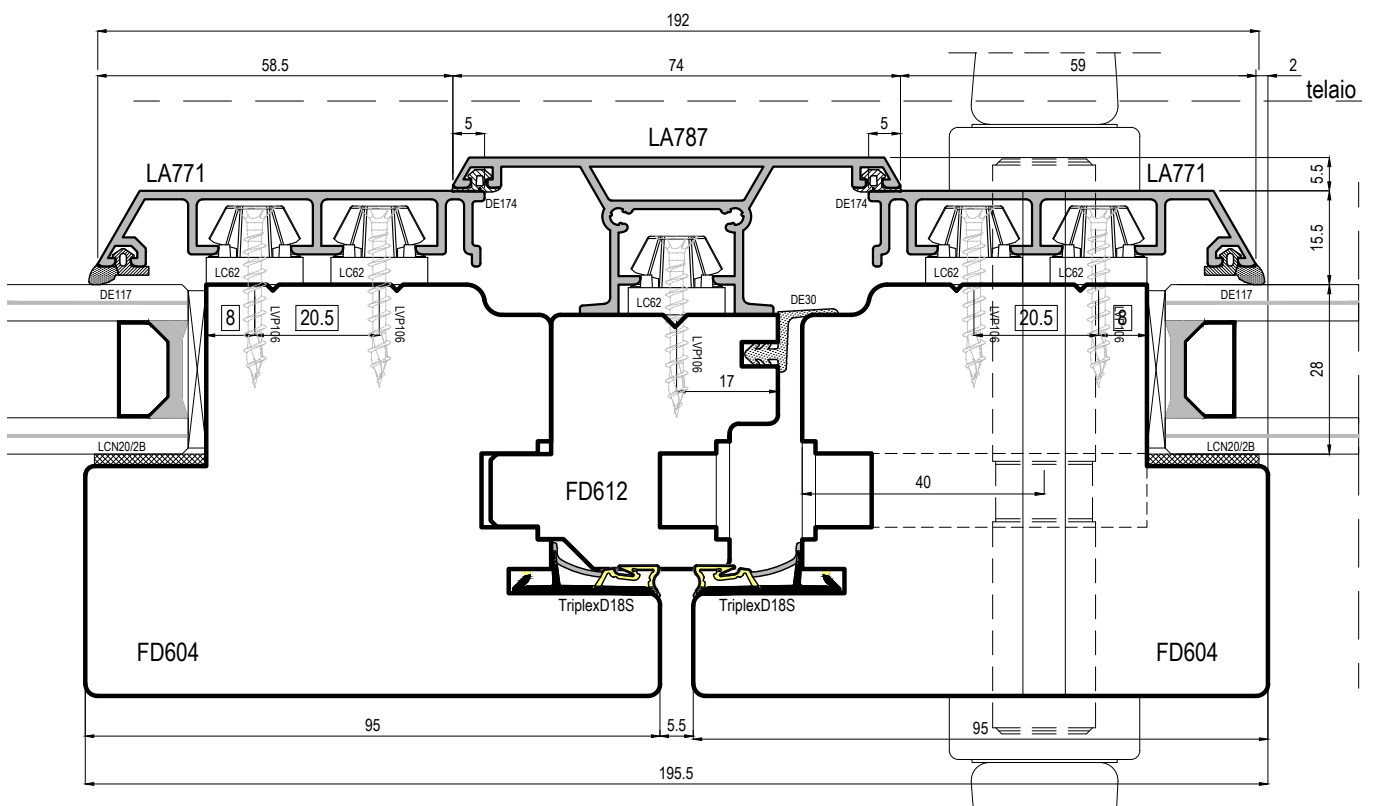
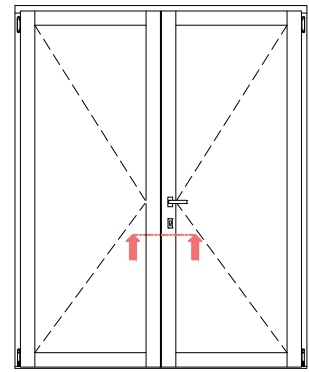

Profilo maggiorato utilizzabile solo sui 4 lati anta

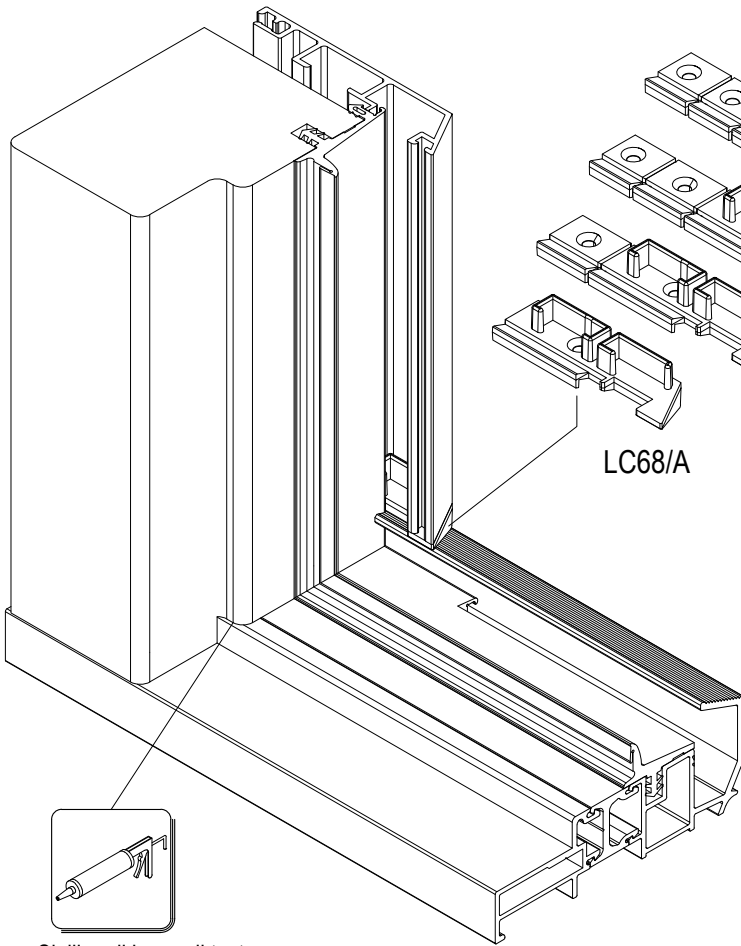

LC68/A

Sigillare il legno di testa

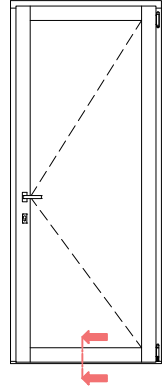

Alluminio	Accessorio
LA780	LC68/A tagliato
LA793	LC68/A tagliato
LA783	LC68/A tagliato
LA889	LC68/A

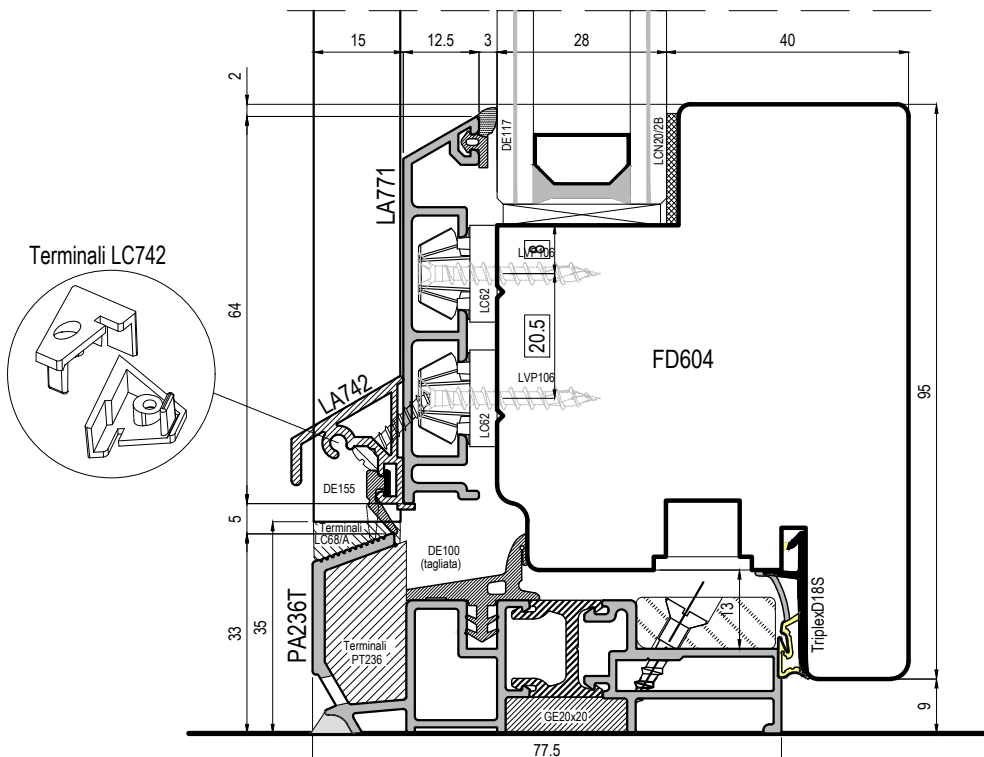
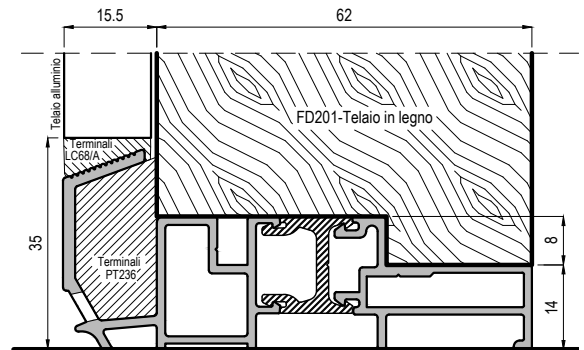

Terminali LC742

uni_one - Sistema Standard

Scala 0.8:1

CT_uni_one Standard-ver.00/02.24

Produced with:
uni_one
 TECHNOLOGY



Conforme alla normativa per l'abbattimento delle barriere architettoniche BARRIER FREE

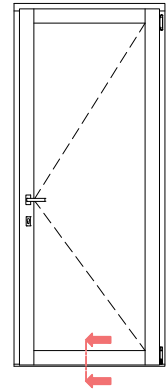
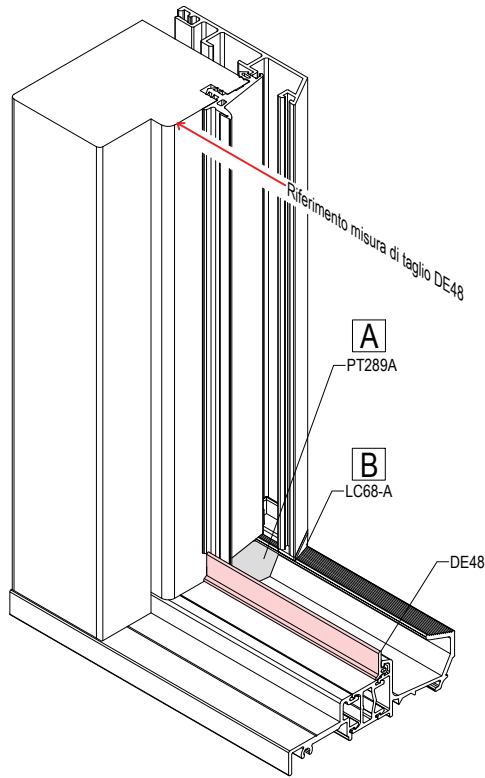

A			B	
Telaio	Accessorio	Misura	Alluminio	Accessorio
FD201-50	PT289A-50	50mm	LA780	LC68/A tagliato
FD201-70	PT289A-70	70mm	LA793	LC68/A tagliato
FD305	PT289A-38	38mm	LA783	LC68/A tagliato
FD312	PT289A-33	33mm	LA889	LC68/A
FD104	PT289A-70	70mm		

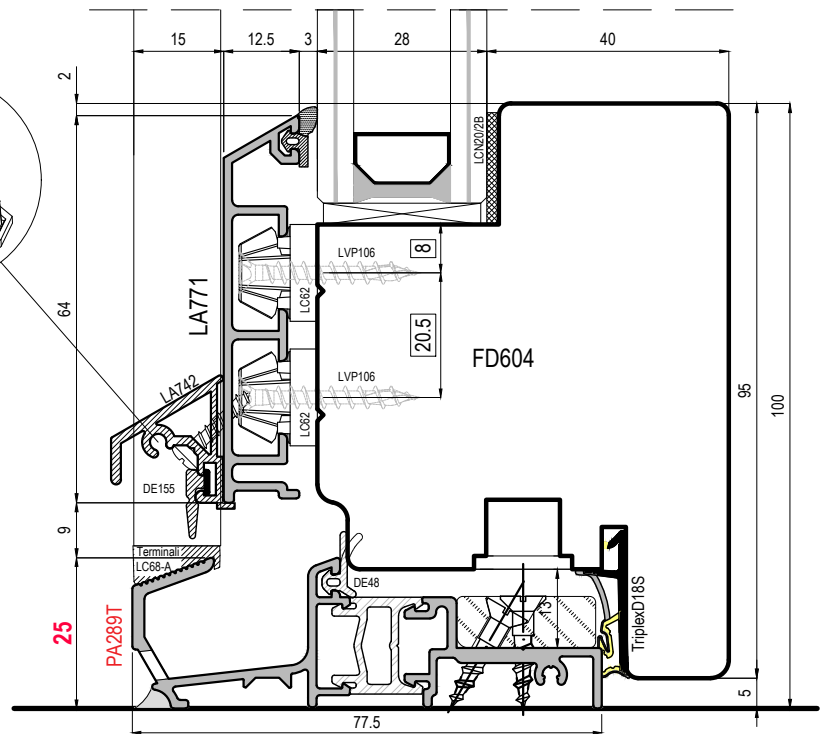
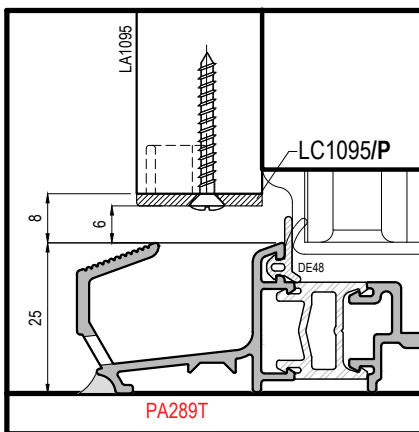
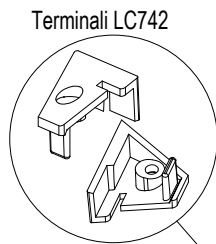
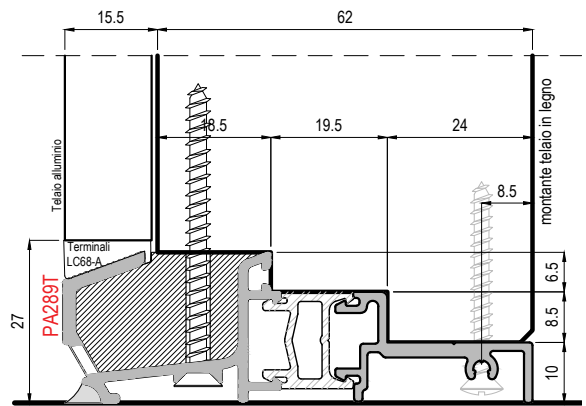

uni_one - Sistema Standard

Scala 0.8:1

Produced with:



Conforme alla normativa per l'abbattimento delle barriere architettoniche BARRIER FREE

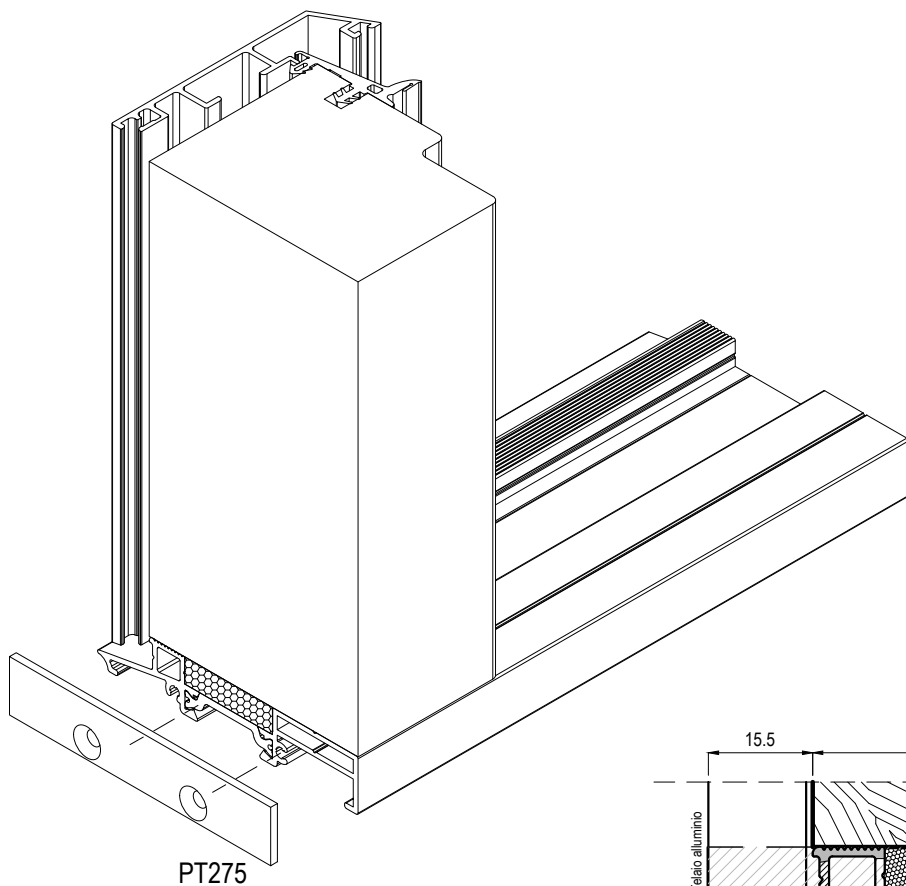

PT275

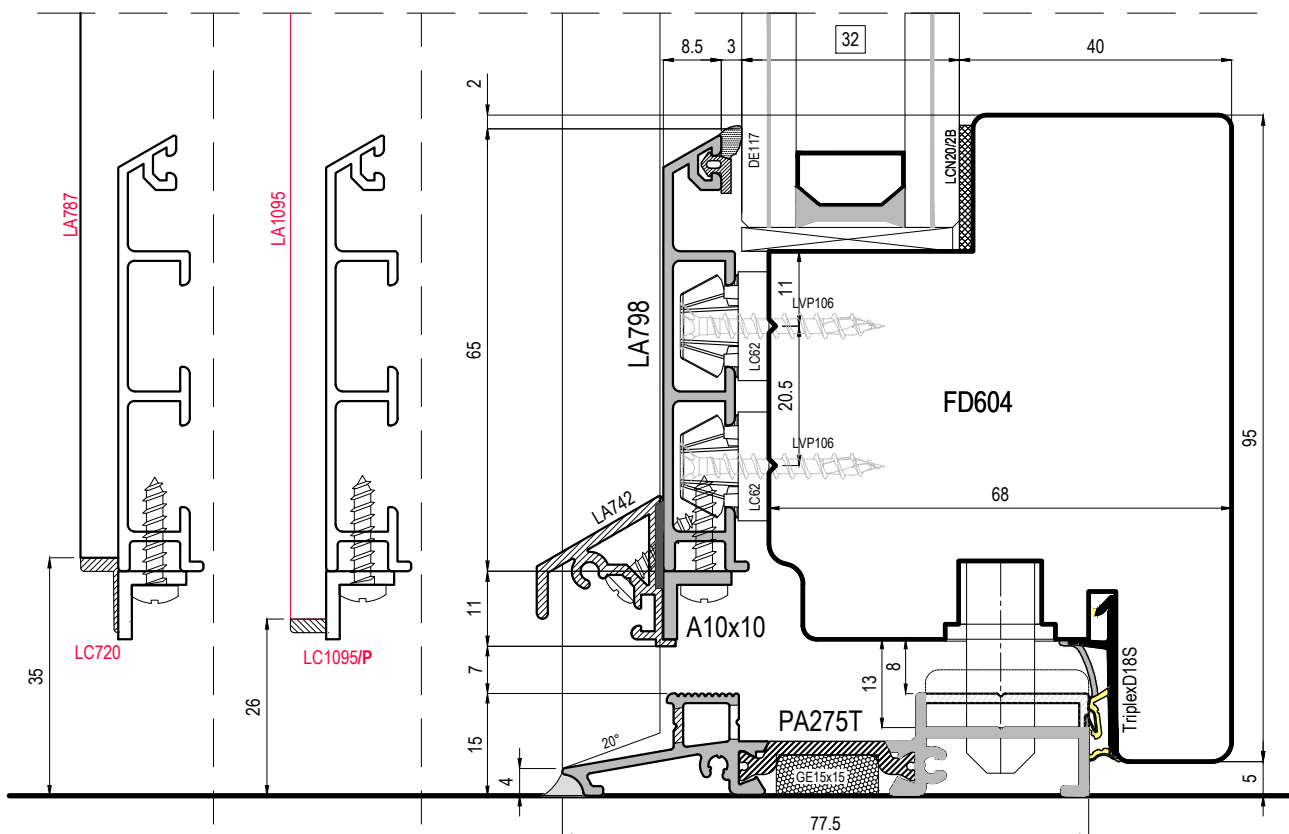
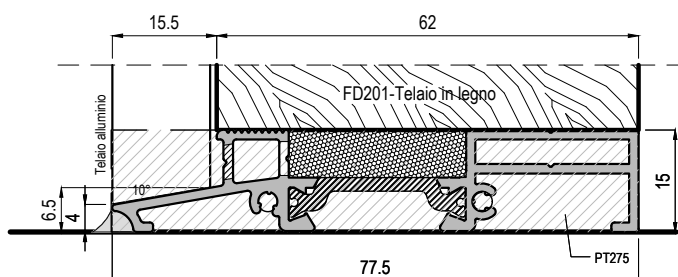
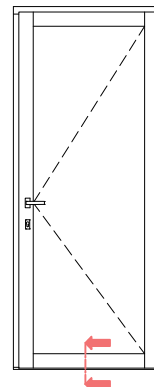

uni_one - Sistema Standard

Scala 0.9:1

CT_uni_one Standard-ver.00/02.24

Produced with:
uni_one
 TECHNOLOGY



Soluzione non coperta da Cascading

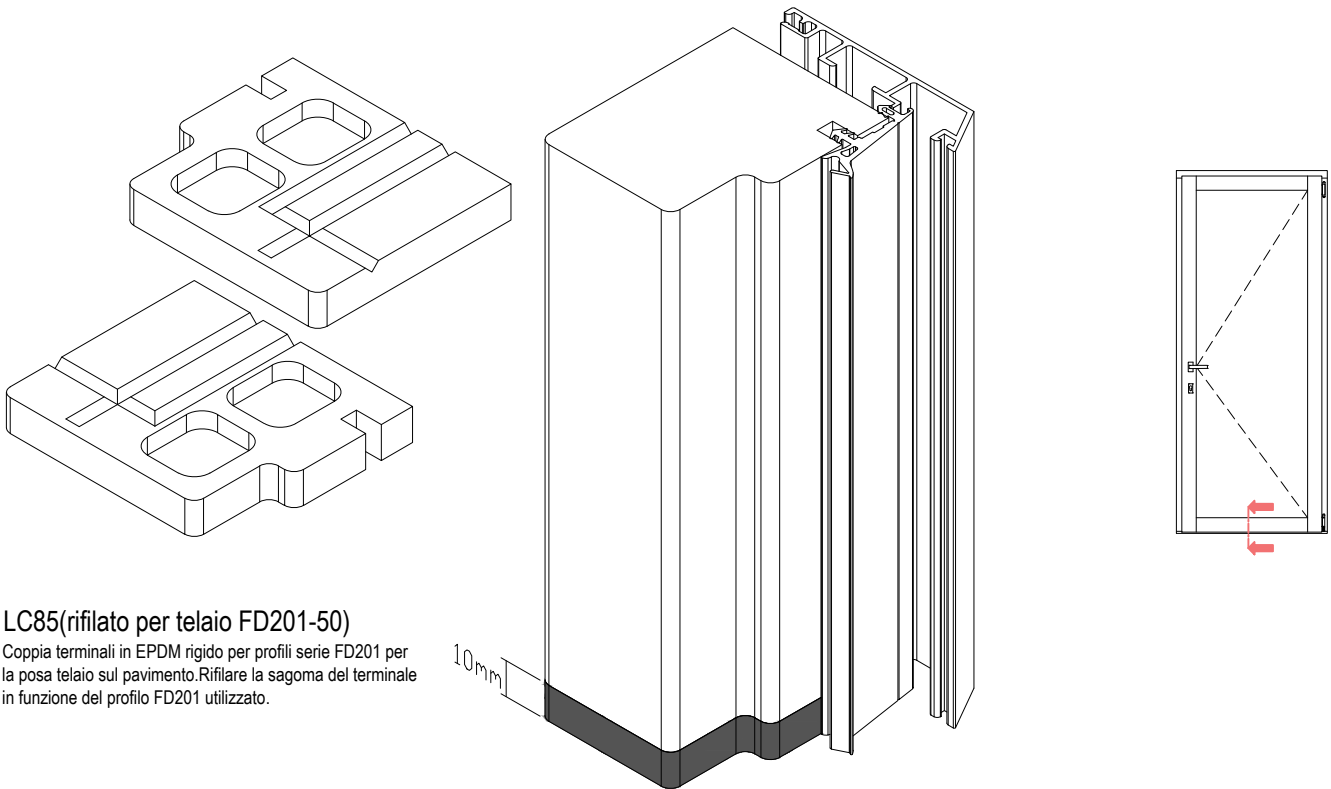

LC85(rifilato per telaio FD201-50)

Coppia terminali in EPDM rigido per profili serie FD201 per la posa telaio sul pavimento. Rifilare la sagoma del terminale in funzione del profilo FD201 utilizzato.

uni_one 90°

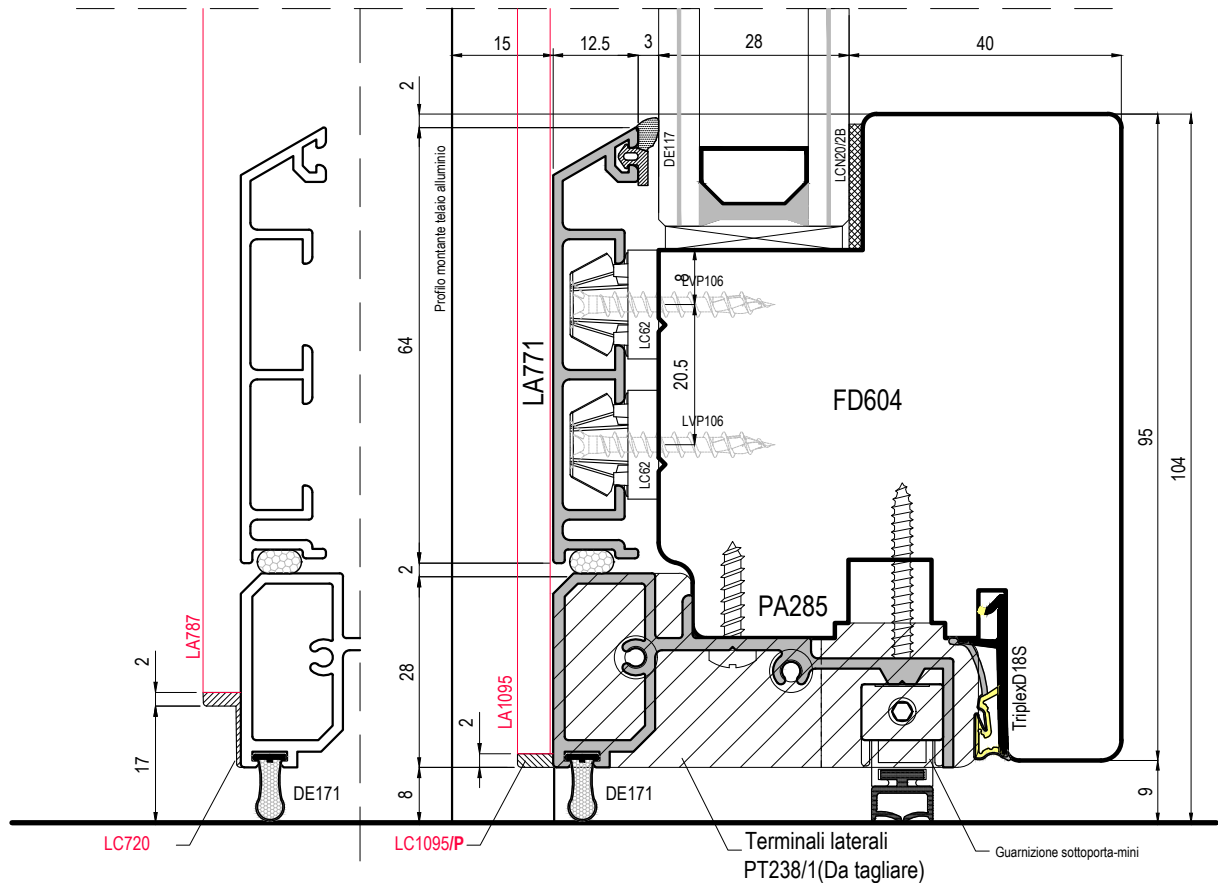

uni_one - Sistema Standard

Scala 0.9:1

CT uni_one Standard-ver.00/02.24

Produced with:
uni_one
TECHNOLOGY

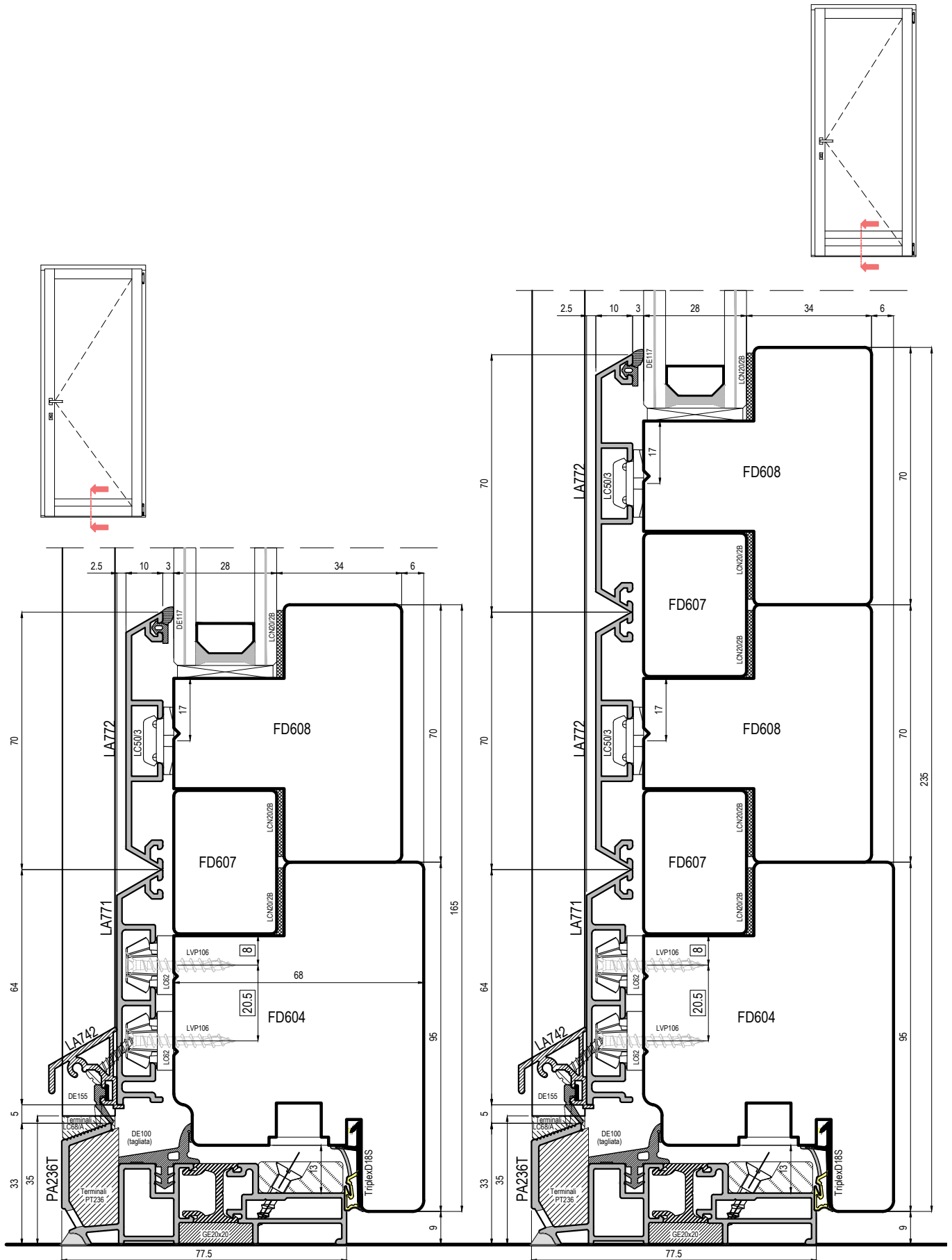

uni_one - Sistema Standard

Scala 0.7:1

CT_uni_one Standard-ver.00/02.24

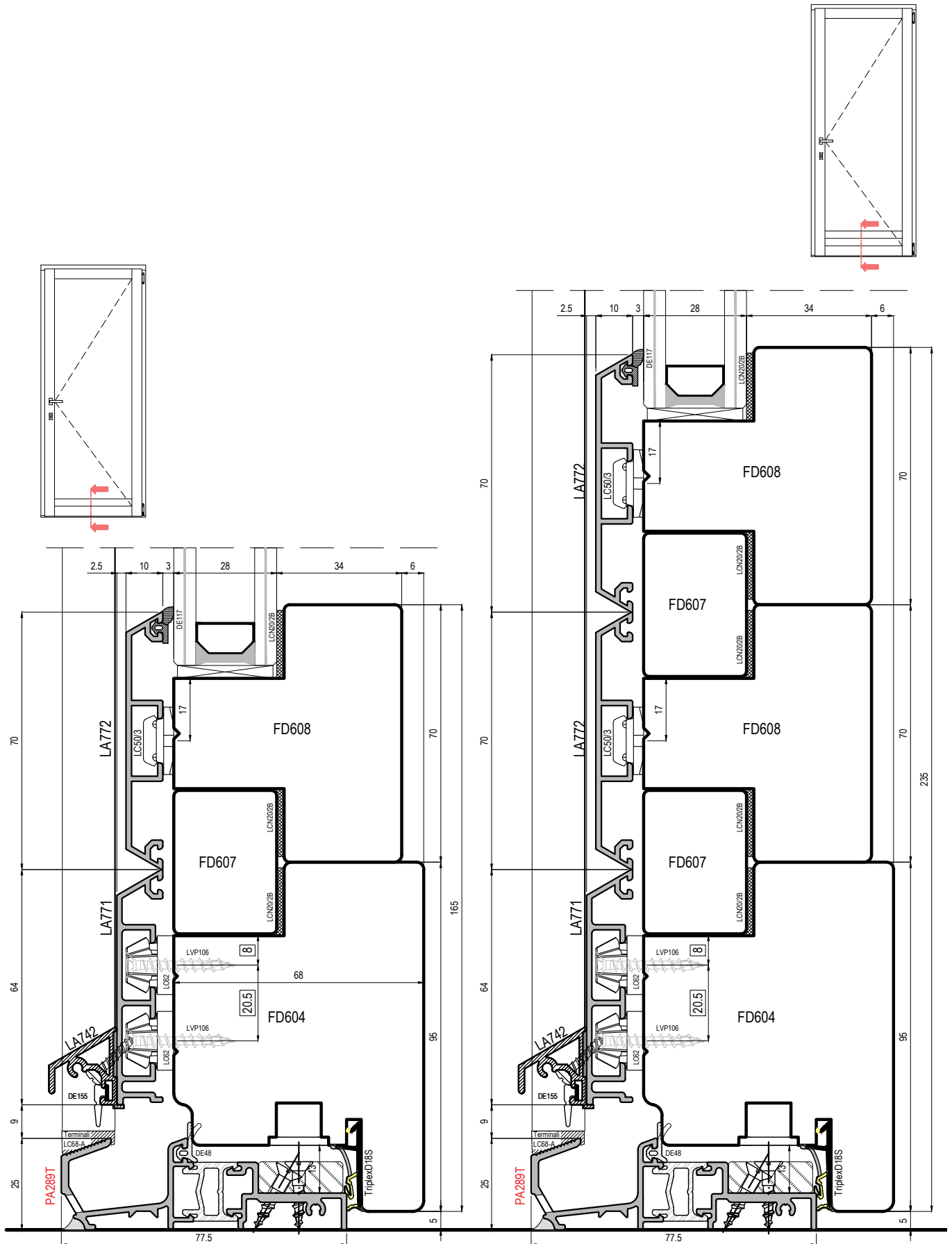

uni_one - Sistema Standard

Scala 0.7:1

CT_uni_one Standard-ver.00/02.24

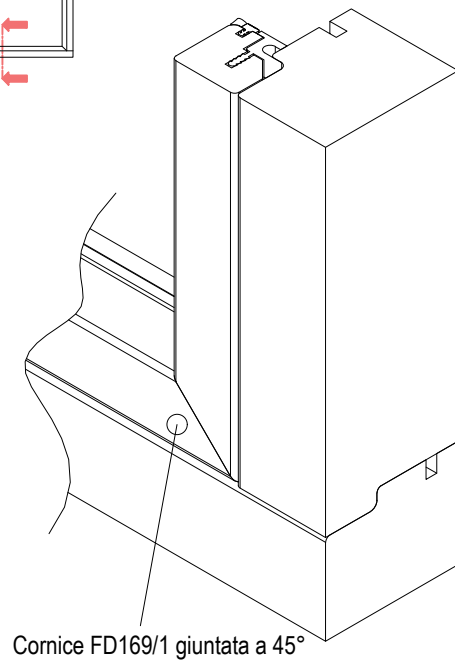
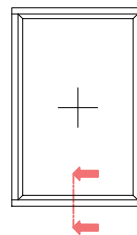
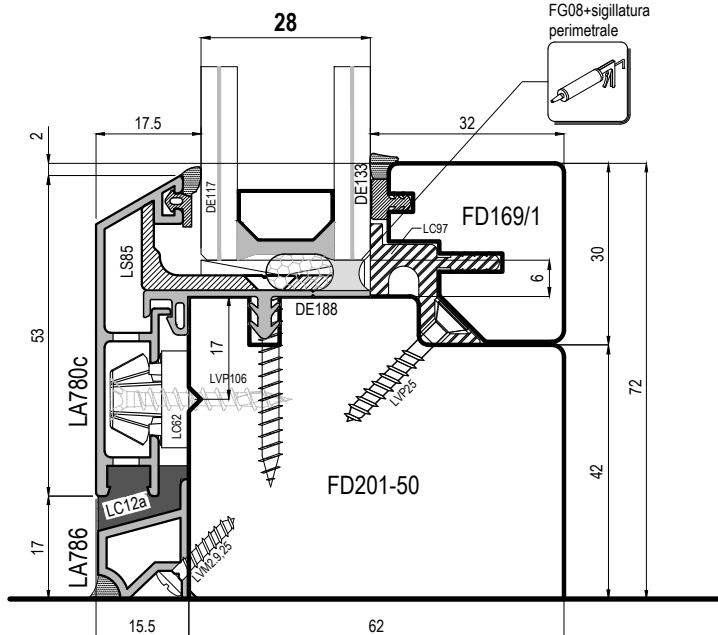
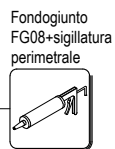
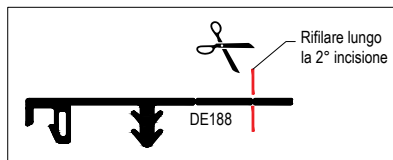
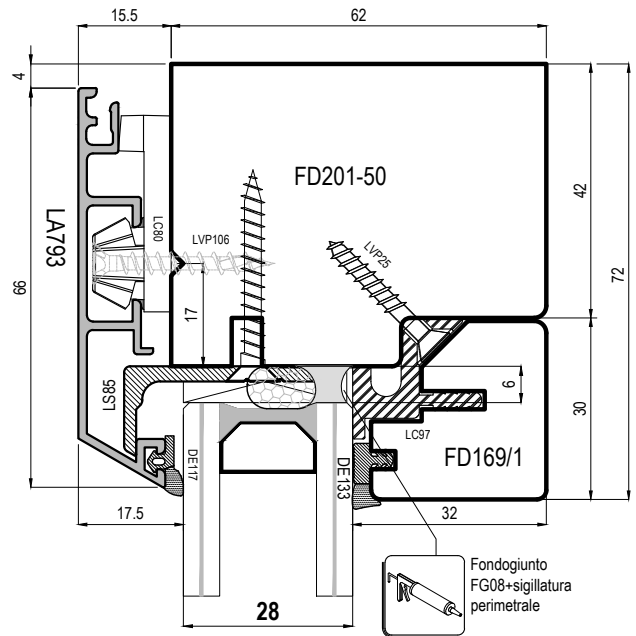
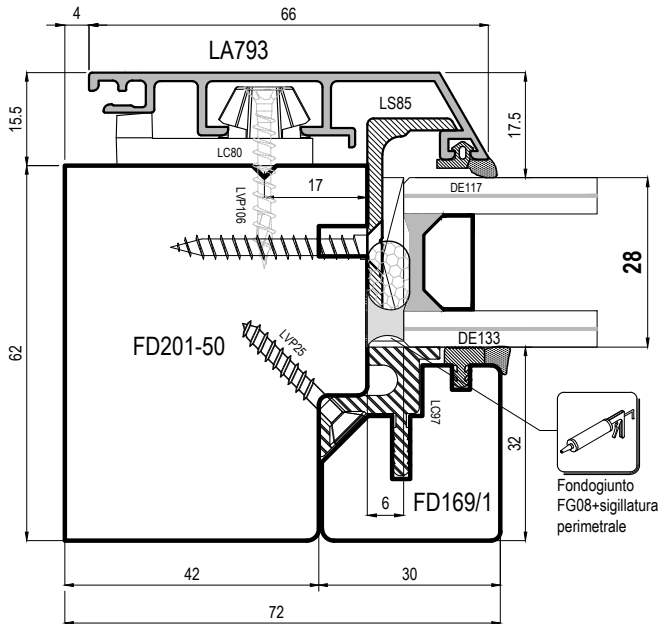
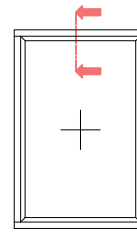
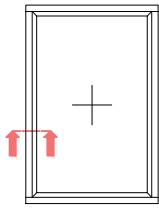

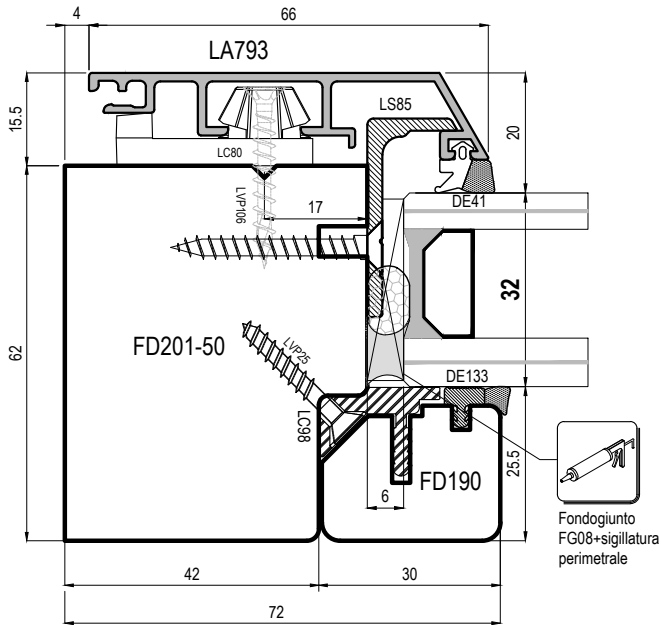
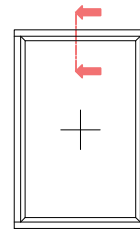
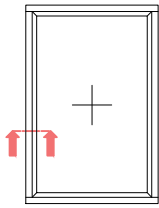

Fondogiunto
FG08+sigillatura
perimetrale

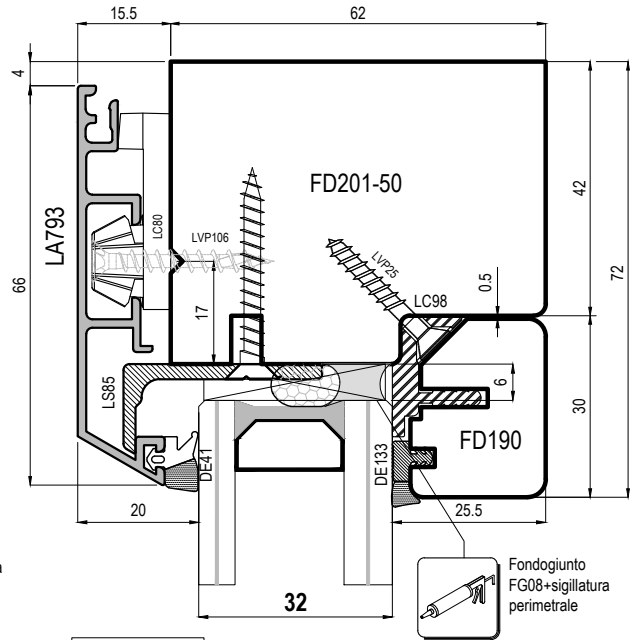

Fondogiunto
FG08+sigillatura
perimetrale

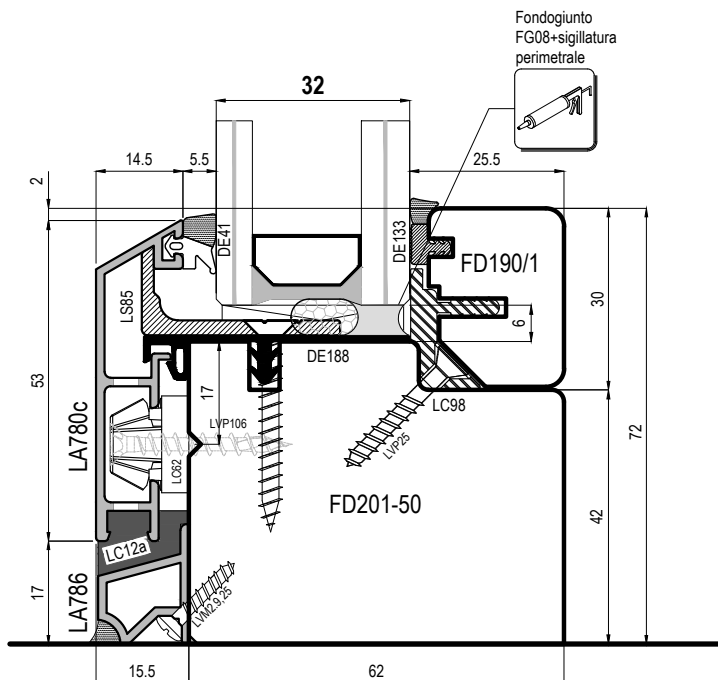
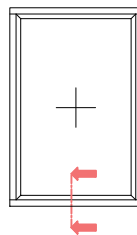

Fondogiunto
FG08+sigillatura
perimetrale

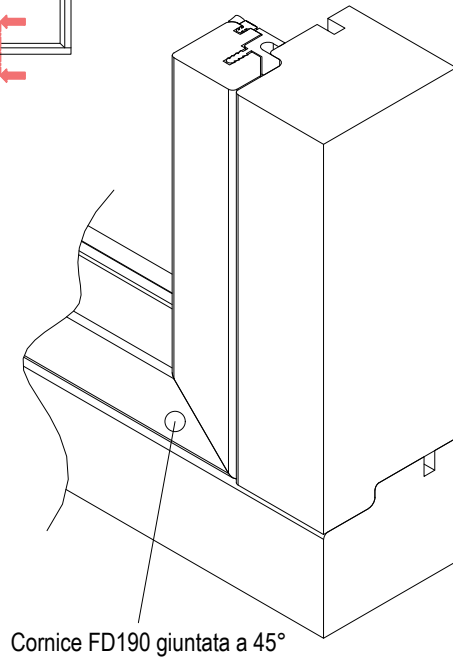

Istruzioni per il montaggio del vetro fisso

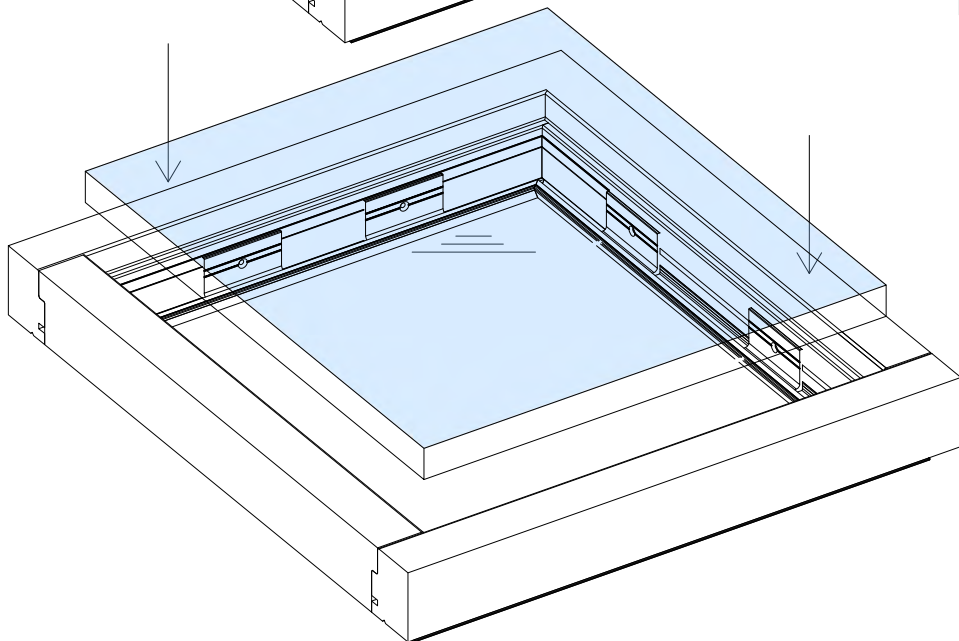
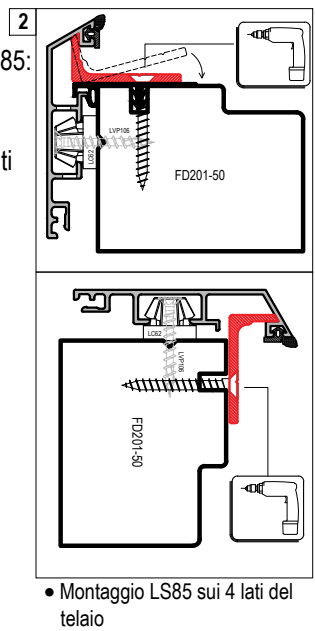
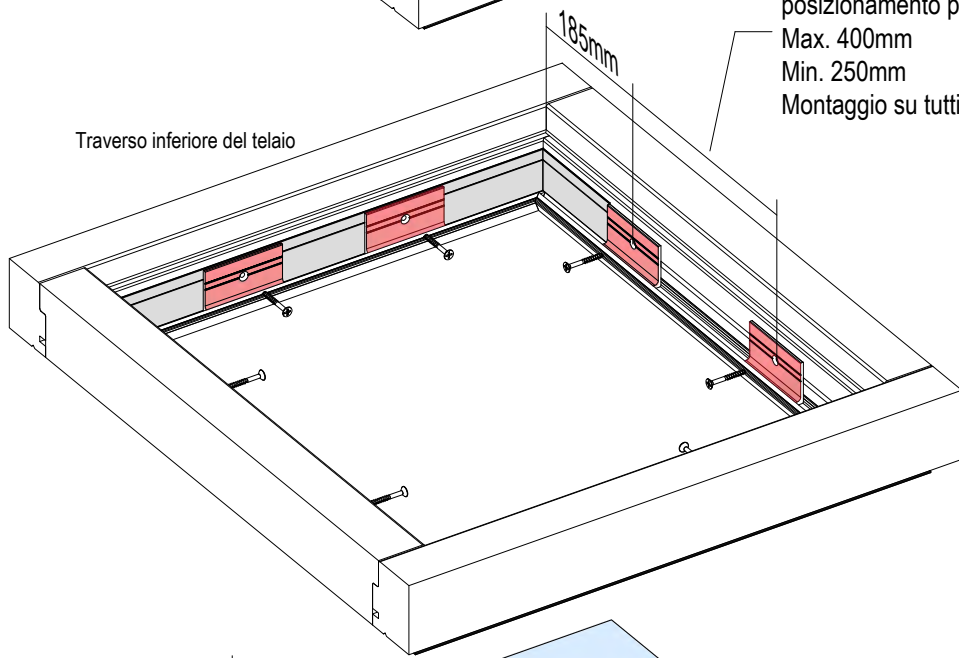
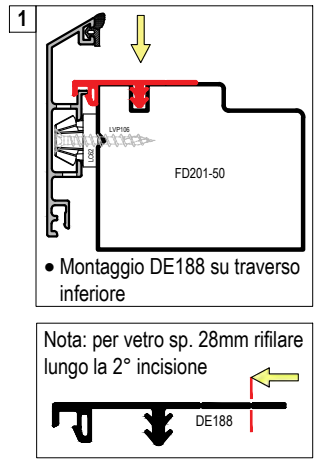
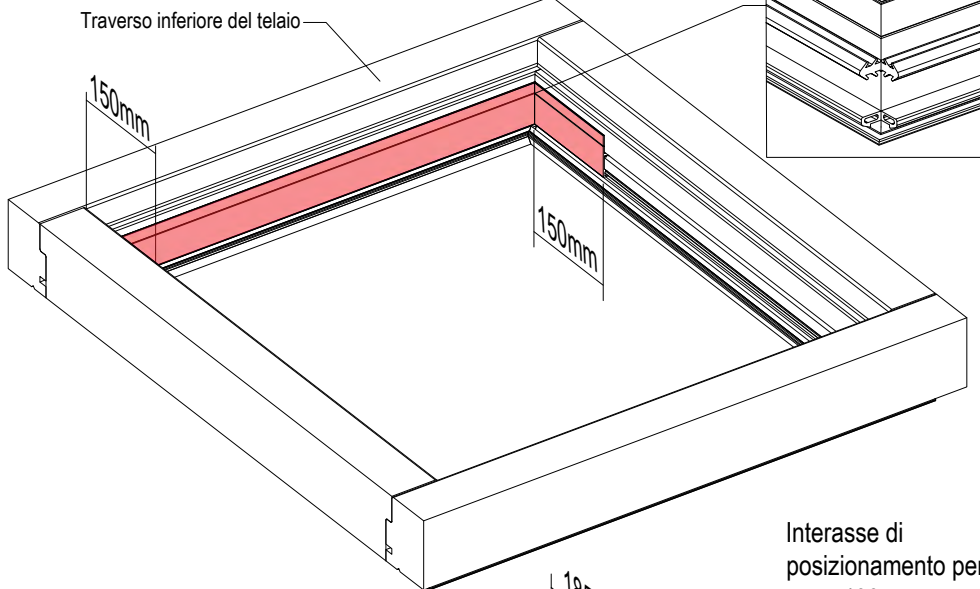

Istruzioni per il montaggio del vetro fisso

Sigillatura con silicone neutro su tutti i 4 lati

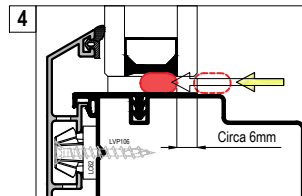
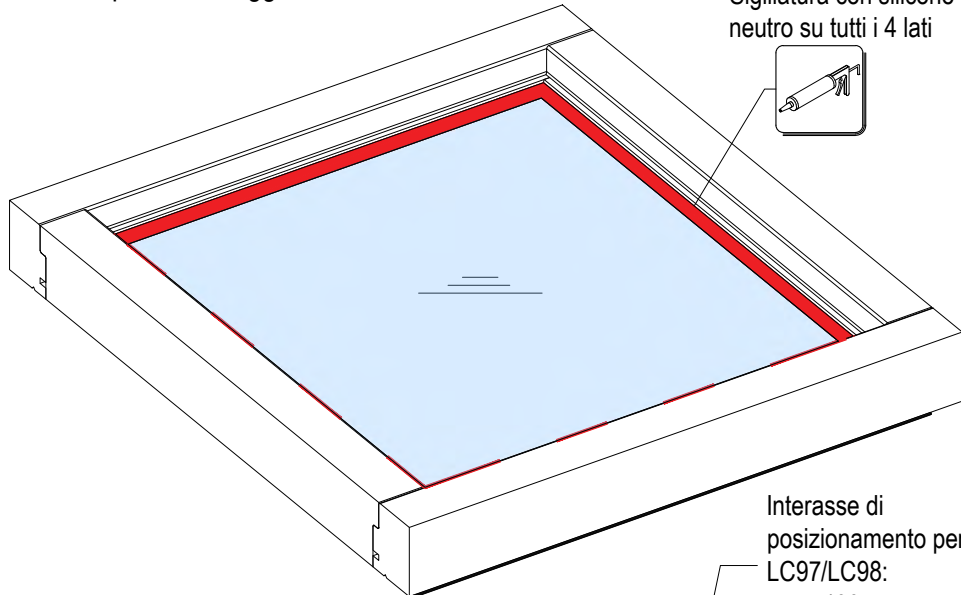

• Inserimento del fodgiunto FG08

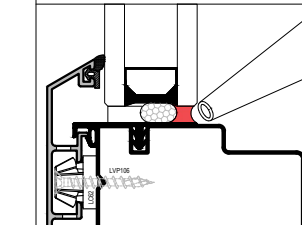

• Sigillatura perimetrale

Interasse di posizionamento per LC97/LC98:
Max. 400mm
Min. 250mm
Montaggio su tutti i 4 lati

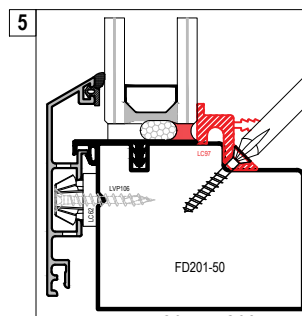

• Montaggio LC97 o LC98

Accessorio in nylon
LC97 vetro sp. 28mm
LC98 vetro sp. 32mm
(viti incluse LVP25)

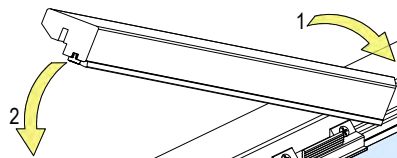
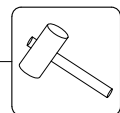
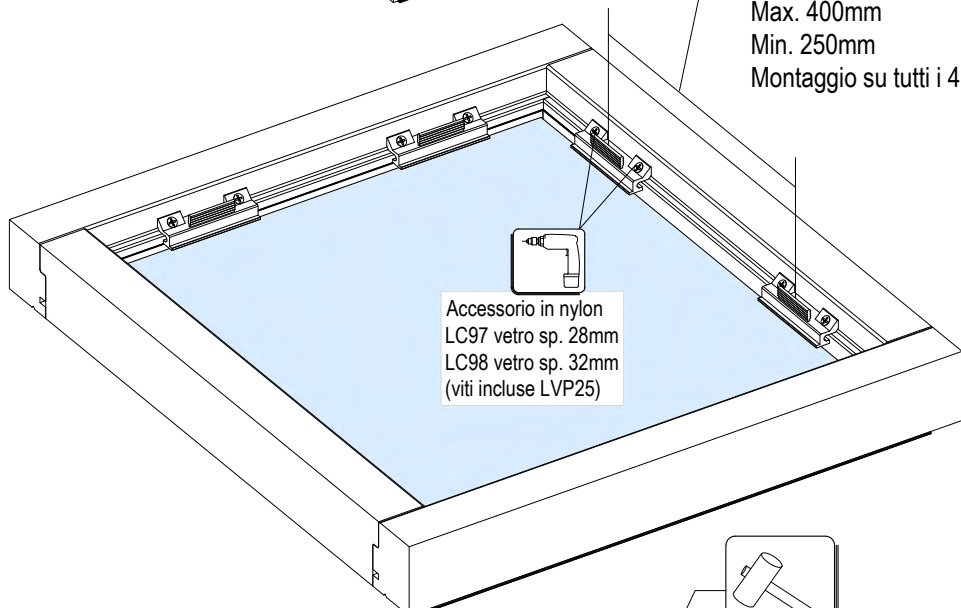

Giunzione con taglio dei fermavetri a 45°

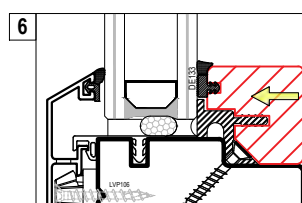
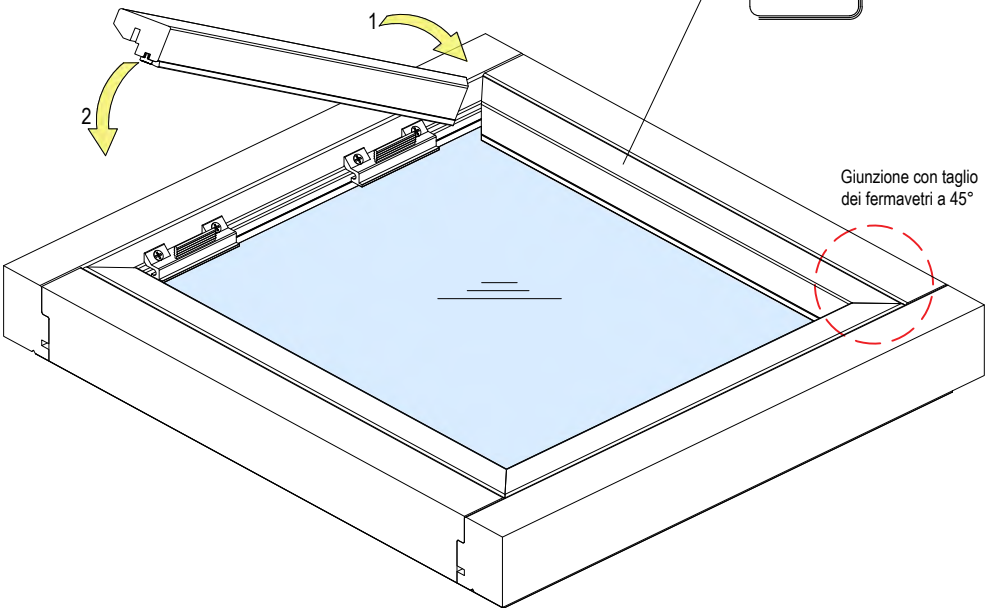

• Montaggio del fermavetro in legno

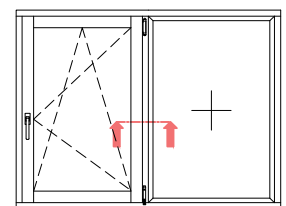
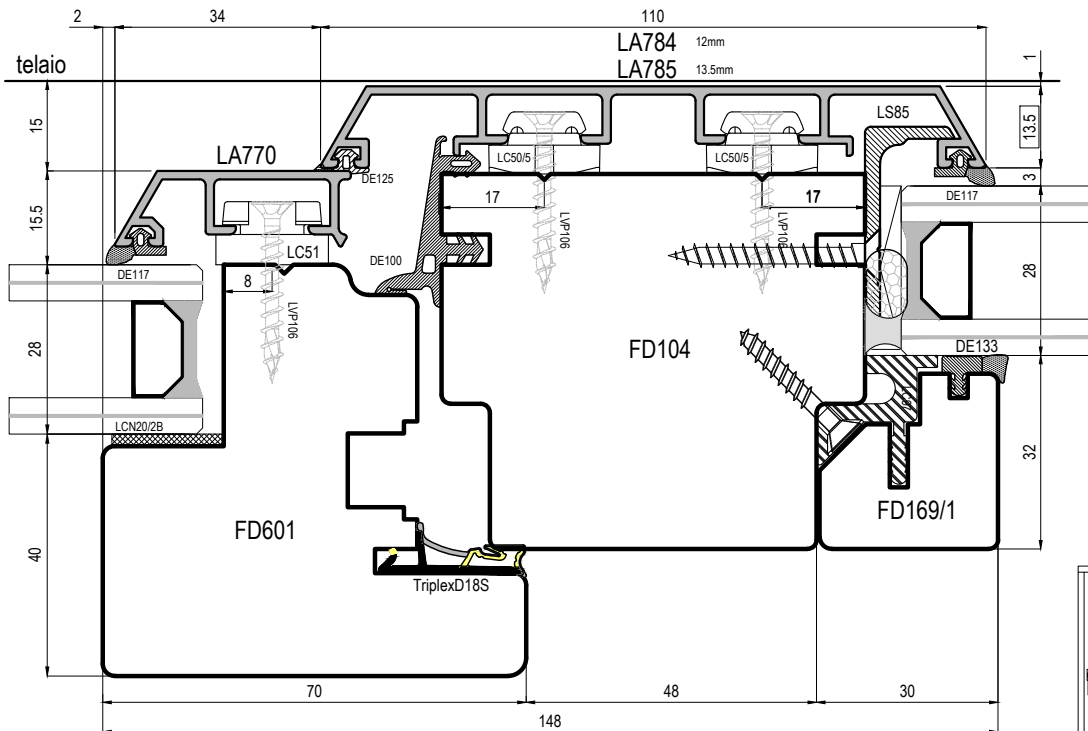
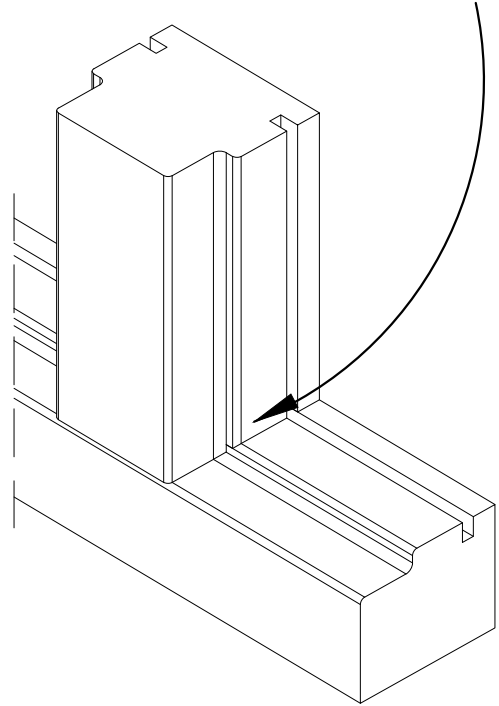
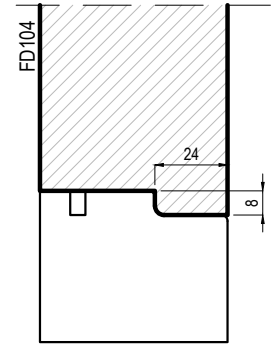
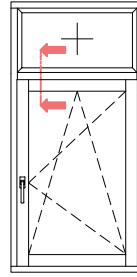
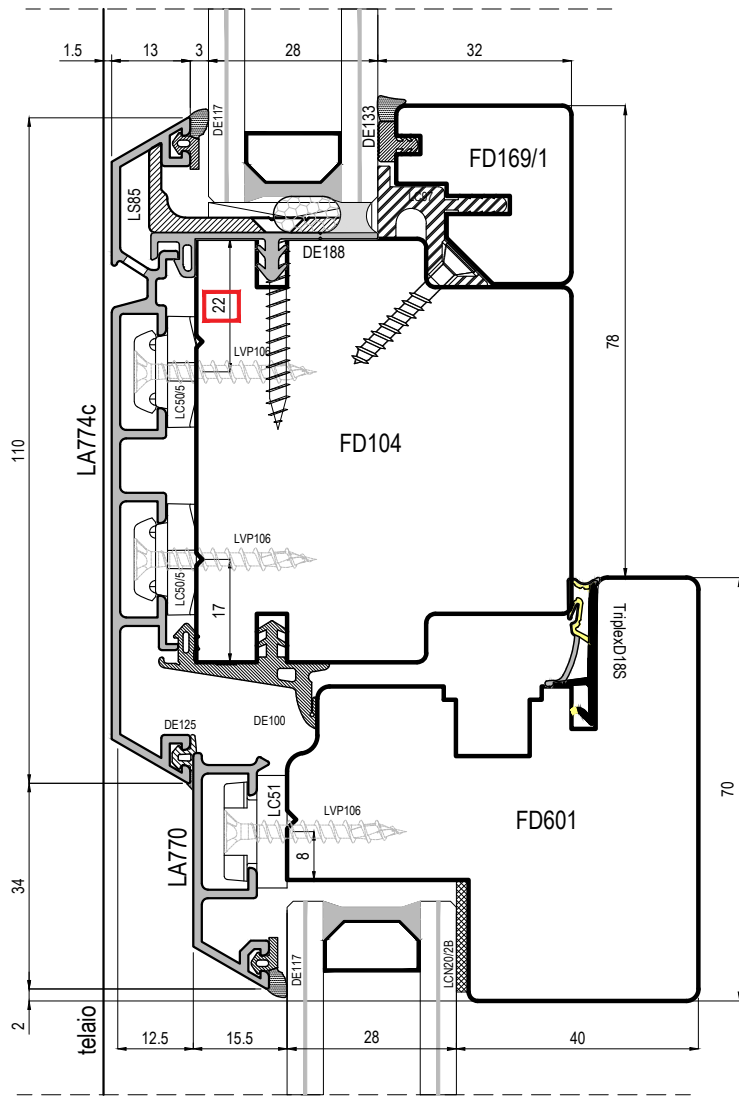

uni_one - Sistema Standard

Scala 0.8:1

CT_uni_one Standard-ver.00/02.24

Produced with:
uni_one
 TECHNOLOGY

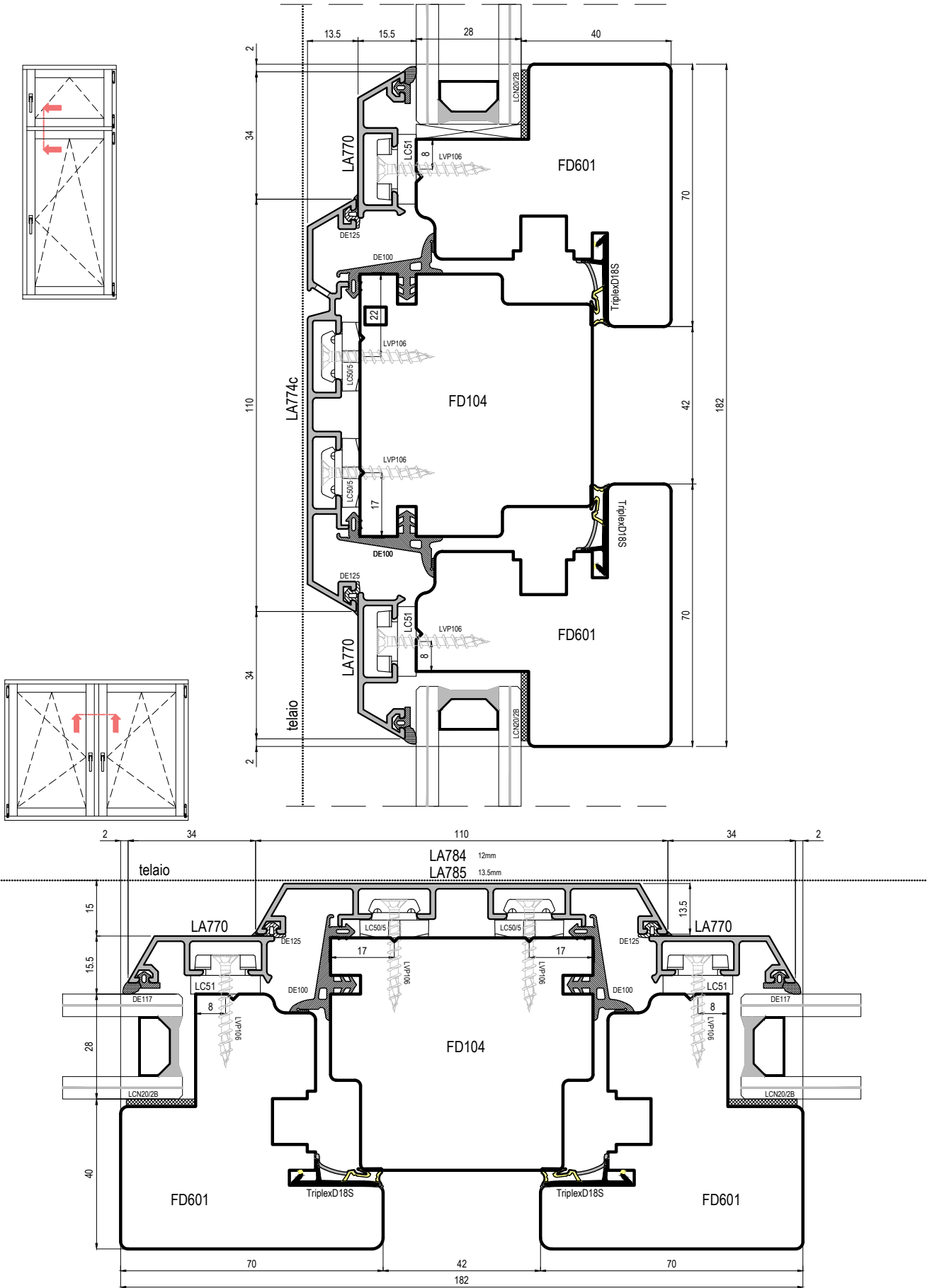

uni_one - Sistema Standard

Scala 0.7:1

CT_uni_one Standard-ver.00/02.24

Particolare giunzione a croce con FD104

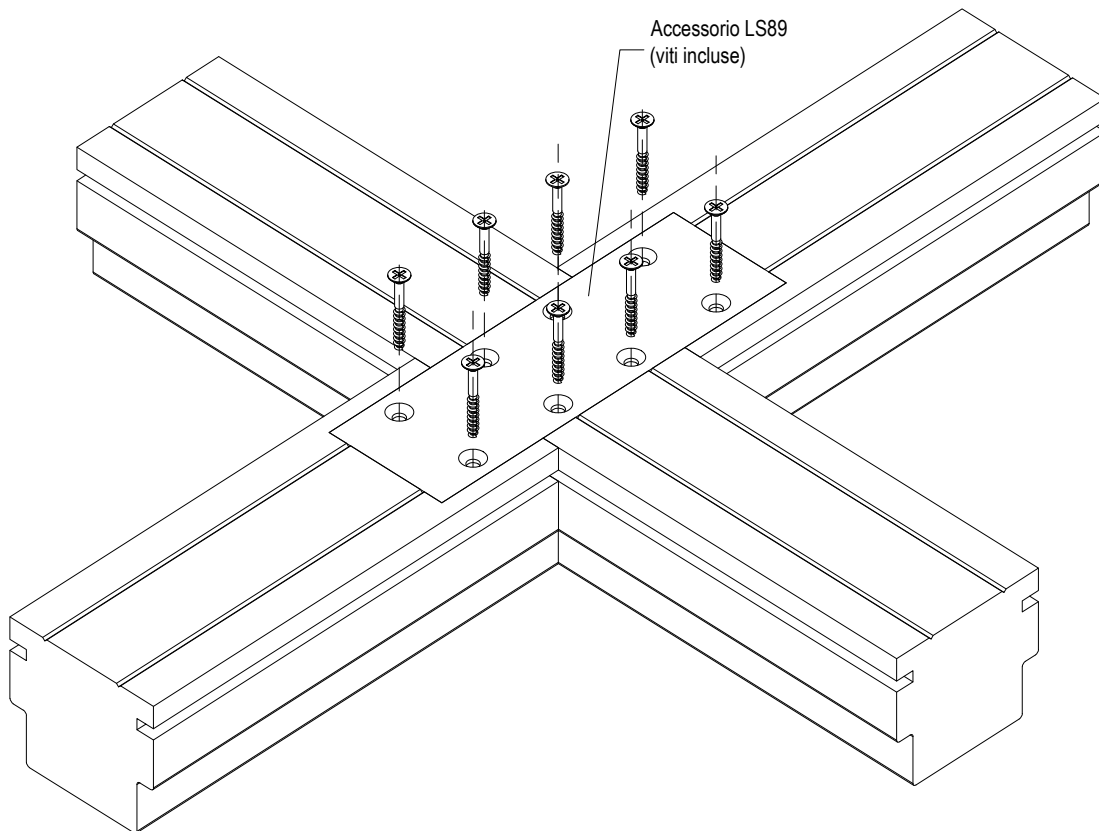
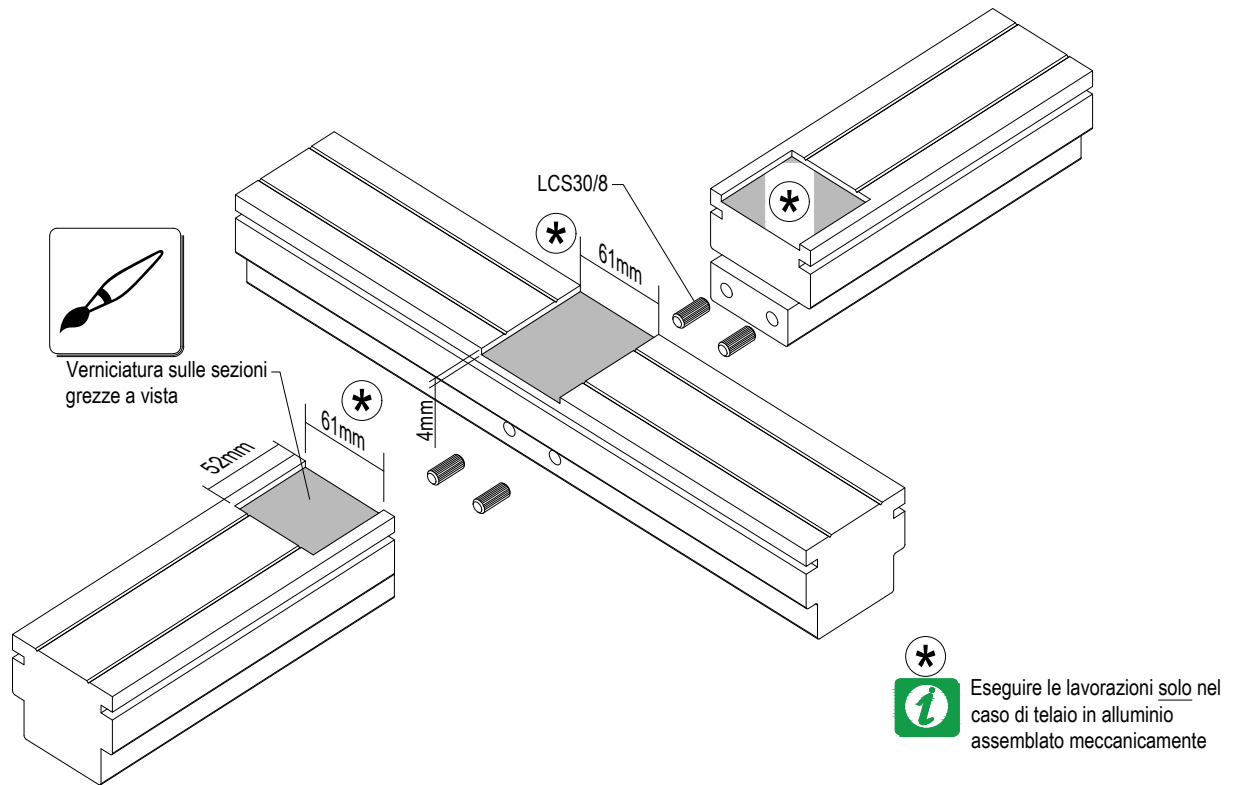



Modifica giunzione tra profilo montante e traverso telaio

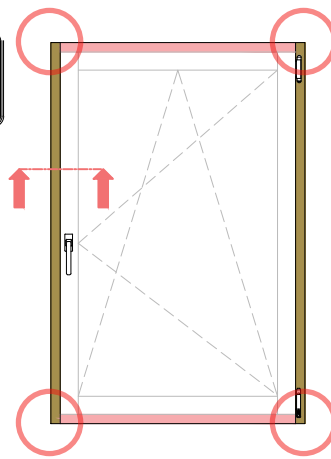
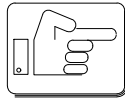

Verniciatura sulle sezioni grezze a vista

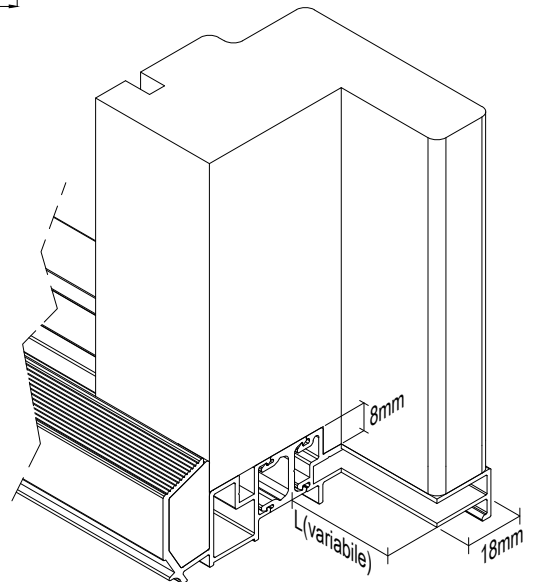
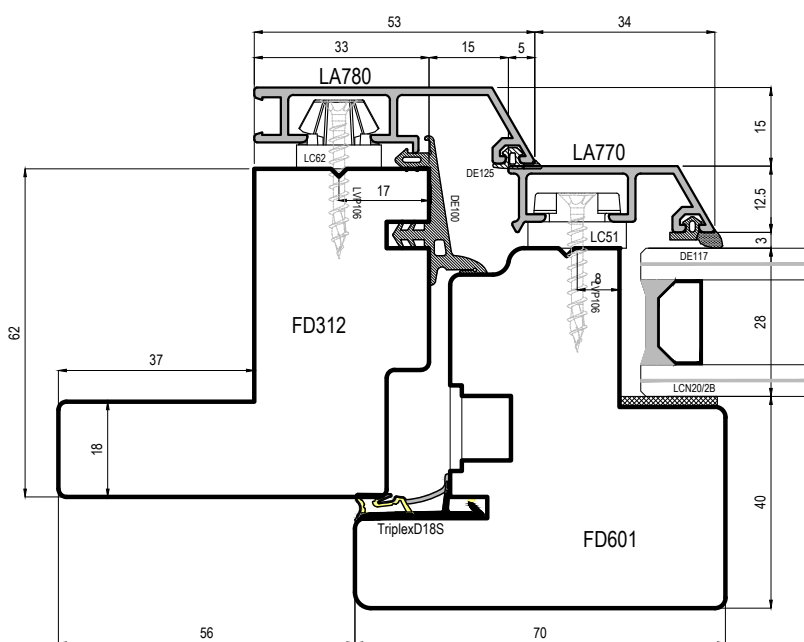
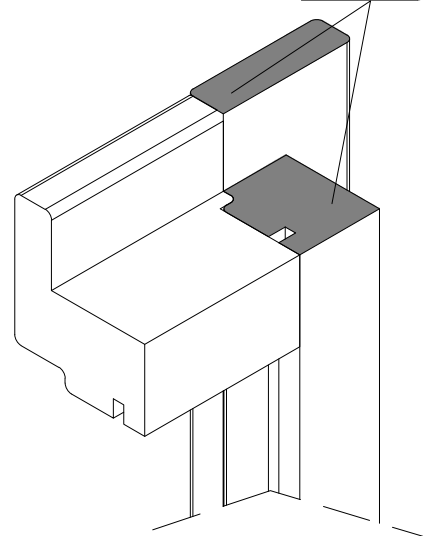
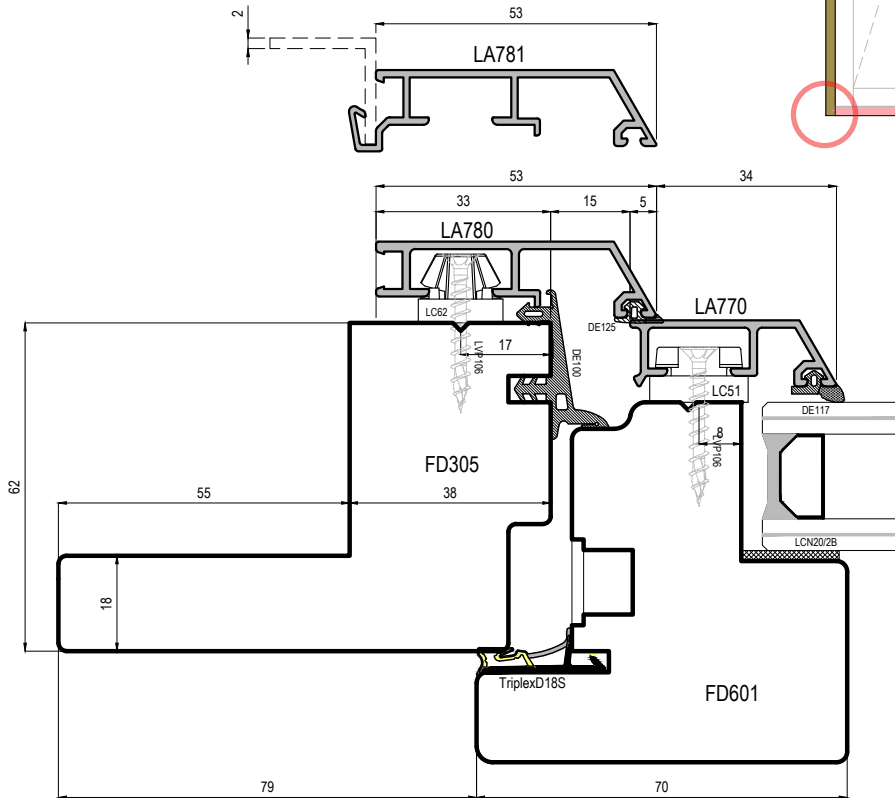

Soglia PA236T

Telaio	Misura L
FD312	37 mm
FD305	55 mm

uni_one - Sistema Standard

Scala 0.7:1

CT_uni_one Standard-ver.00/02.24

Produced with:
uni_one
TECHNOLOGY



Modifica giunzione tra profilo montante e traverso telaio

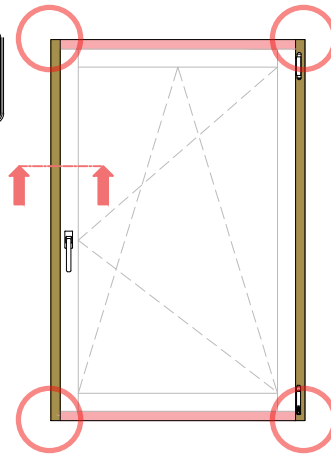
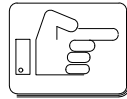

Verniciatura sulle sezioni grezze a vista

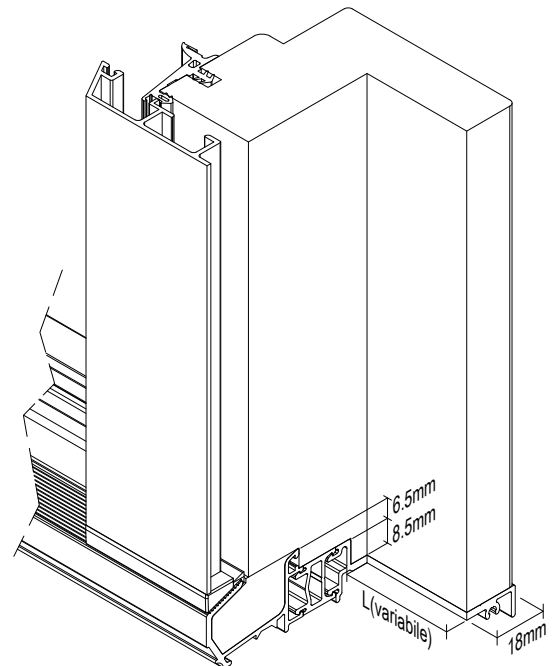
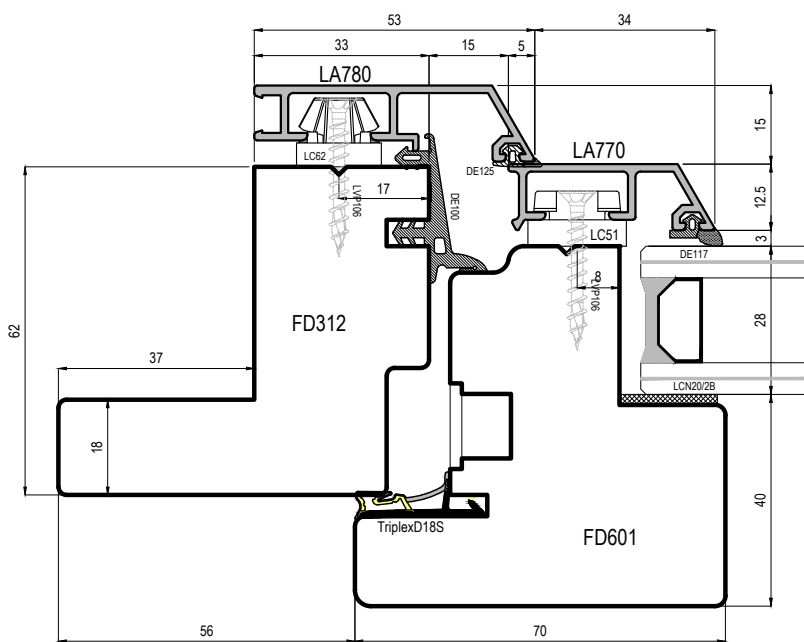
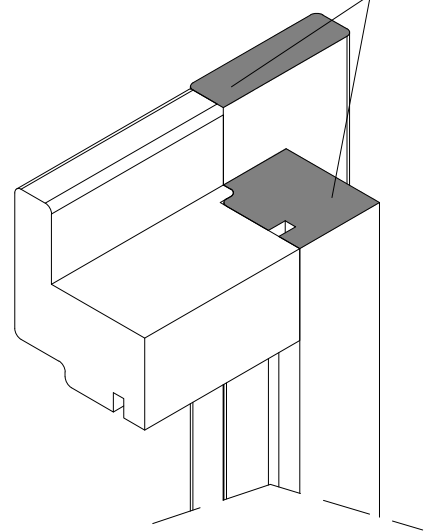
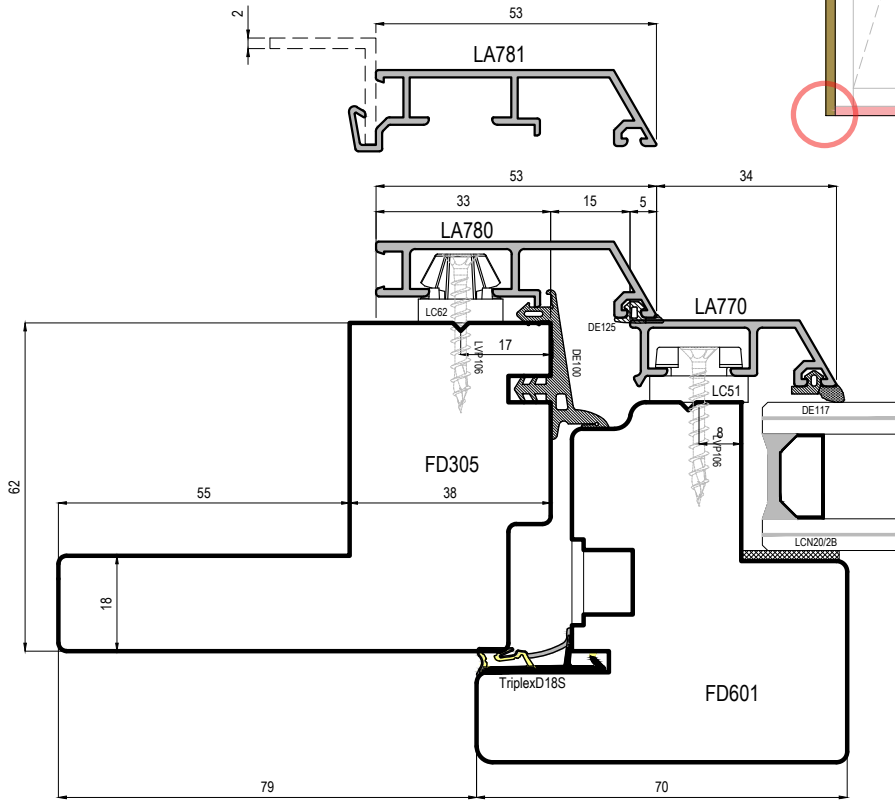

Soglia PA289T

Telaio	Misura L
FD312	37 mm
FD305	55 mm

uni_one - Sistema Standard

Scala 0.7:1

CT_uni_one Standard-ver.00/02.24

Produced with:
uni_one
TECHNOLOGY

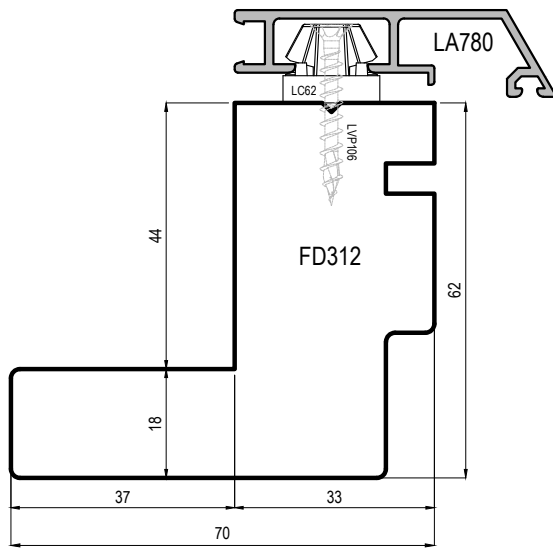

Compensatore trasverso inferiore per FD312

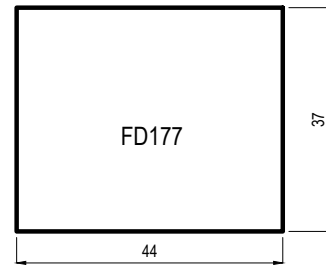

Traverso inferiore ribassato

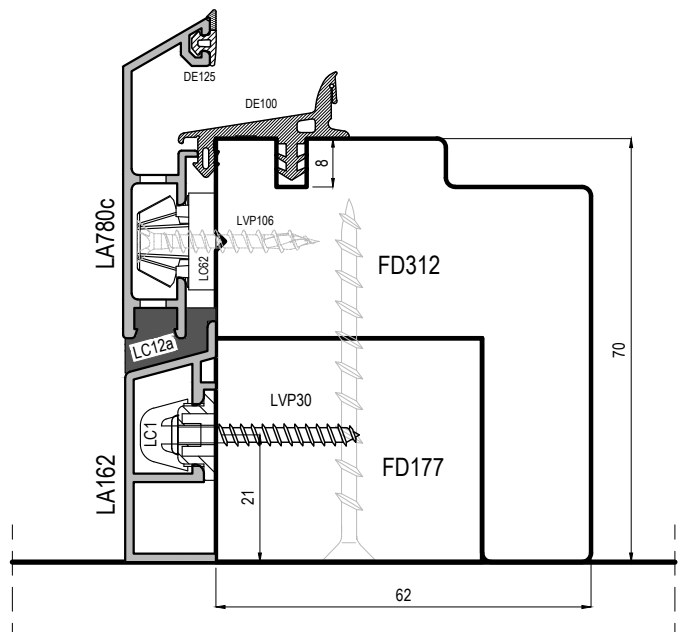
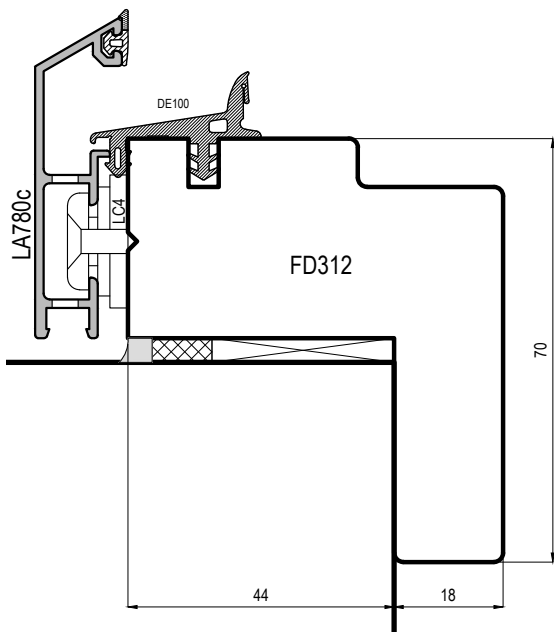
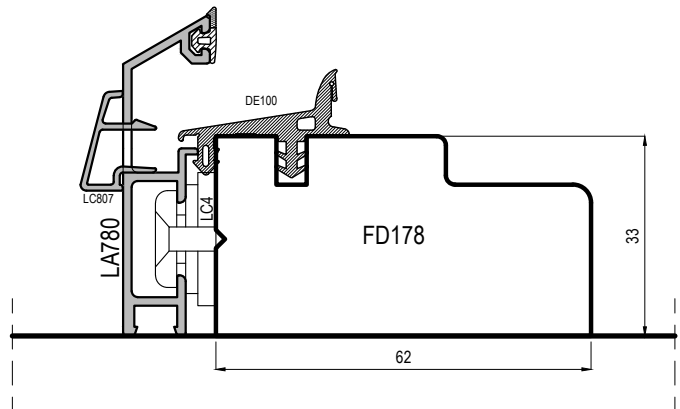
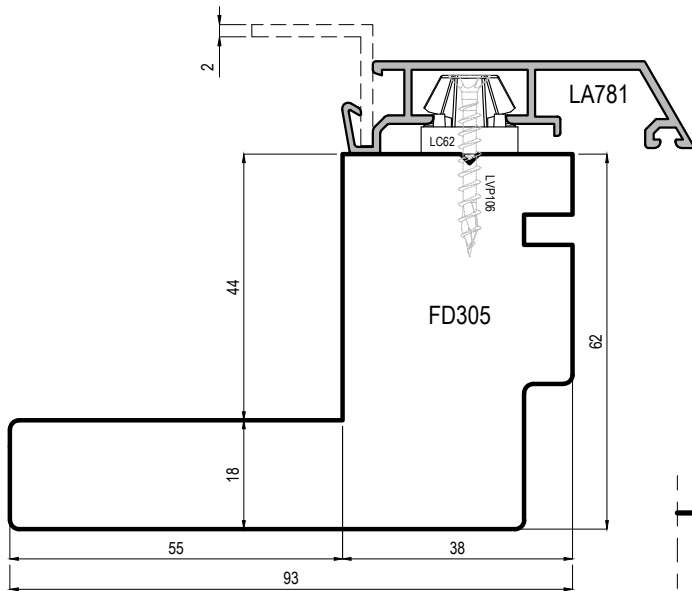
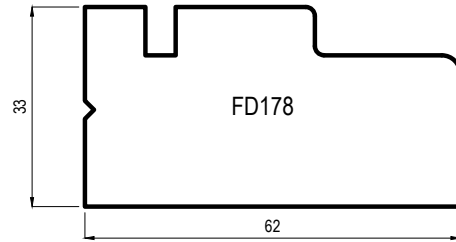

uni_one - Sistema Standard

Scala 0.8:1

CT uni_one Standard-ver.00/02.24

Produced with:
uni_one
TECHNOLOGY

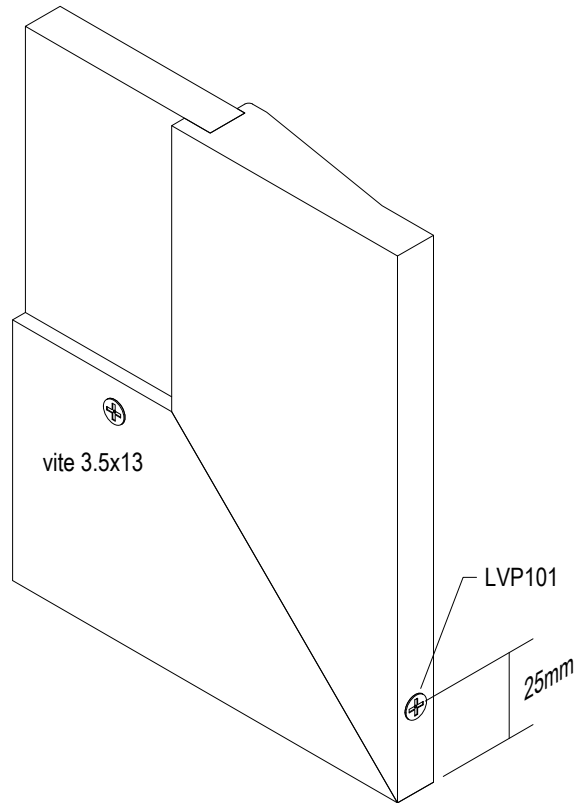
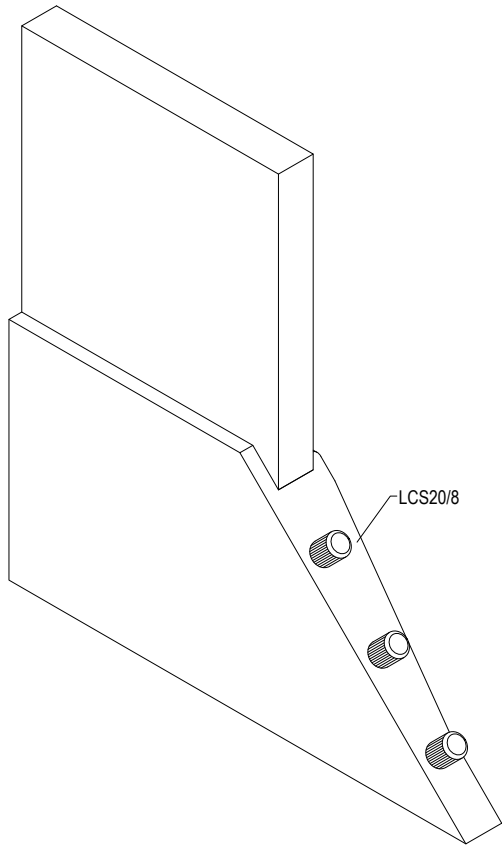
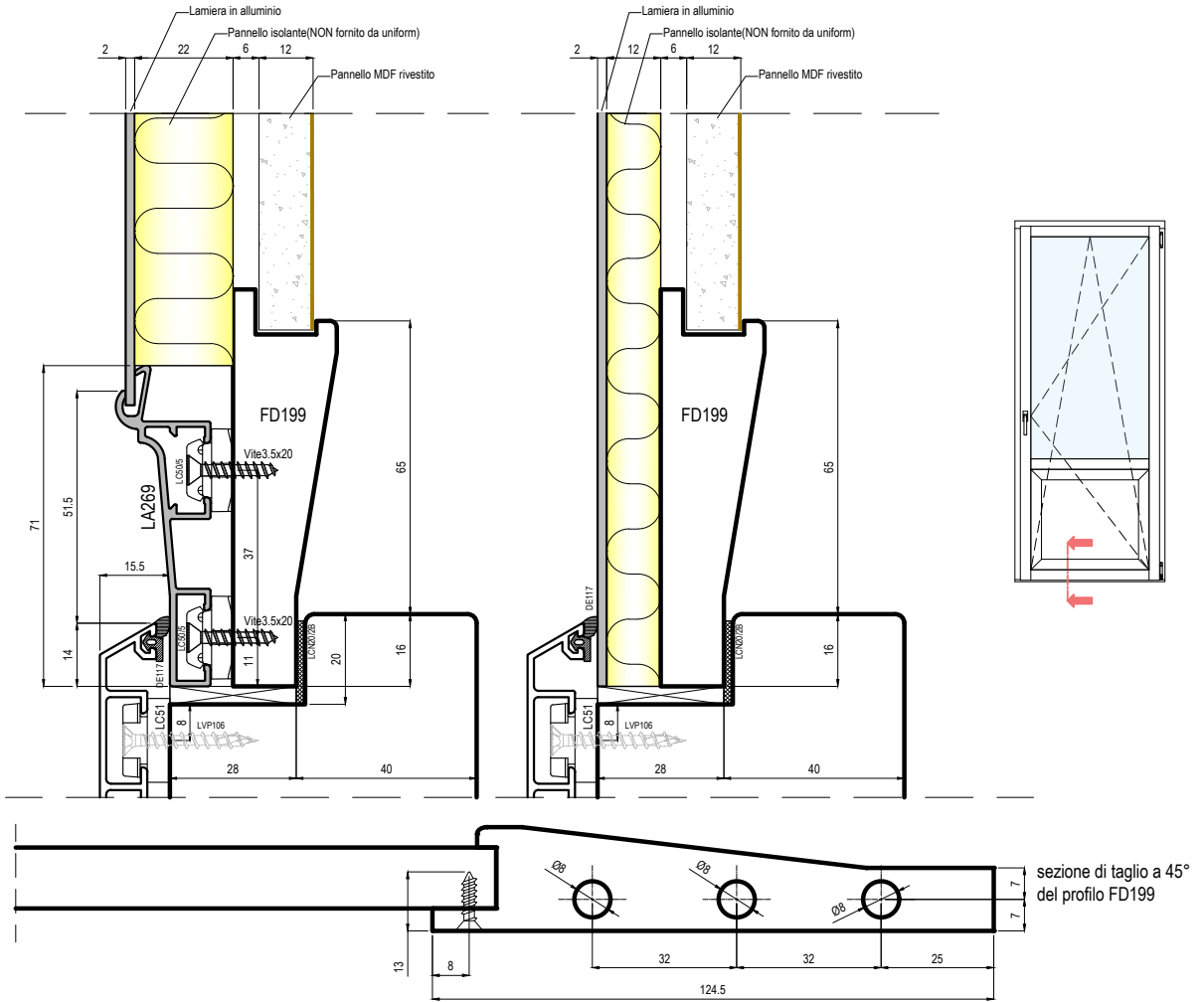

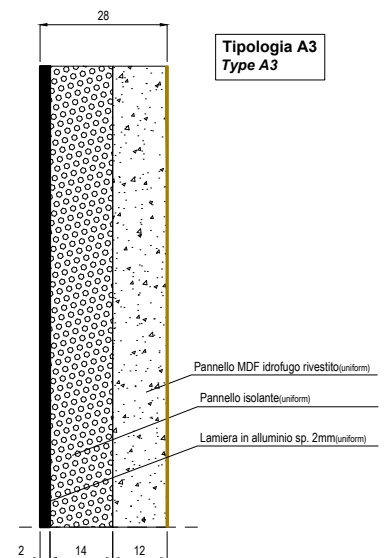
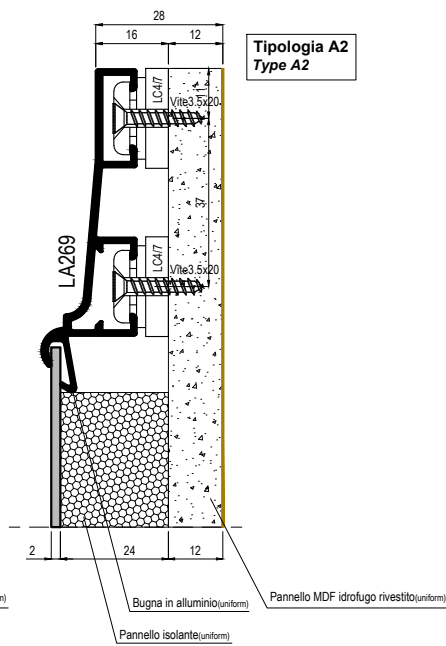
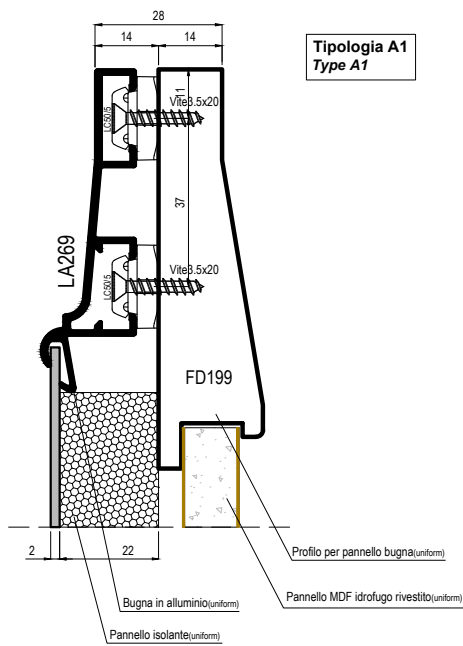
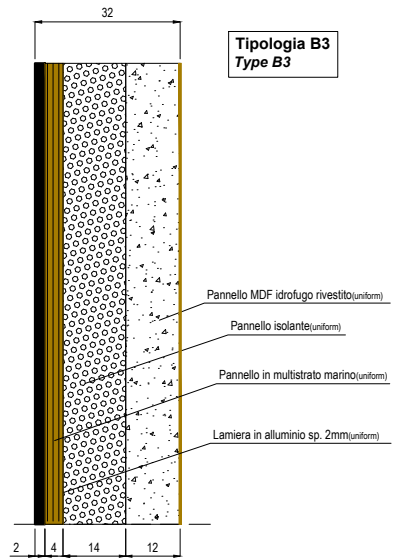
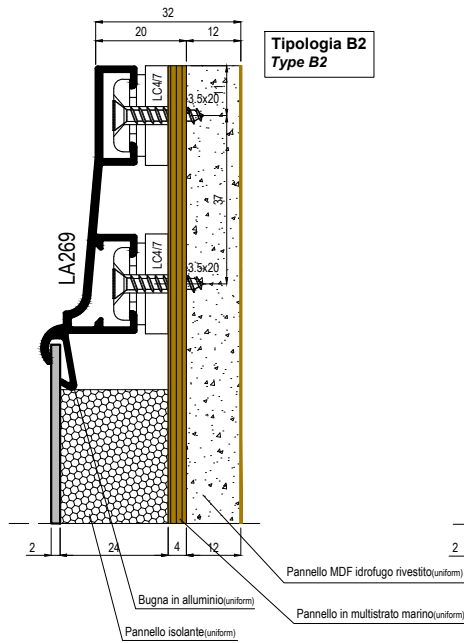
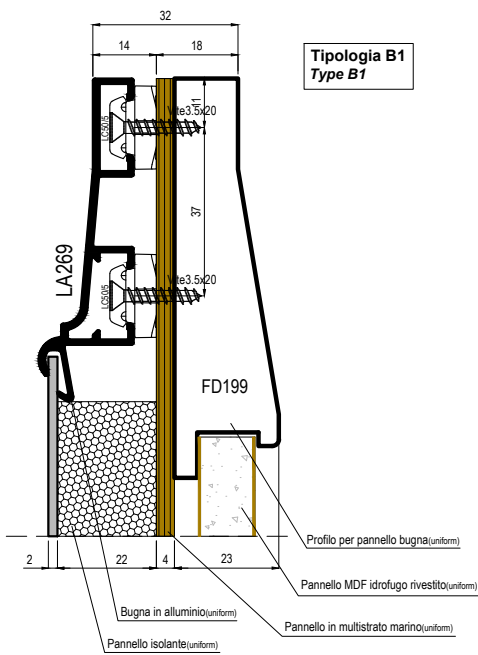

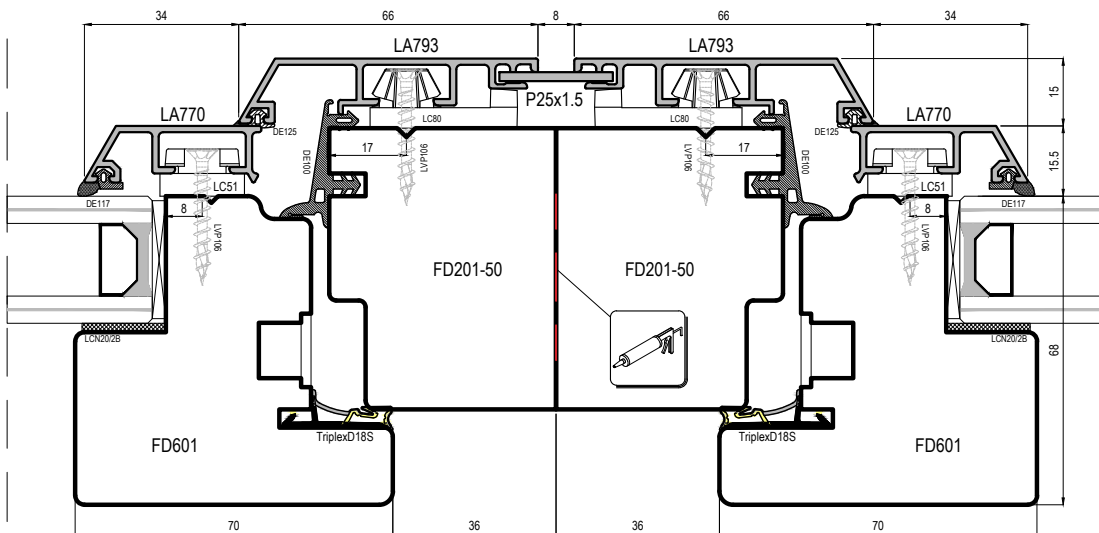
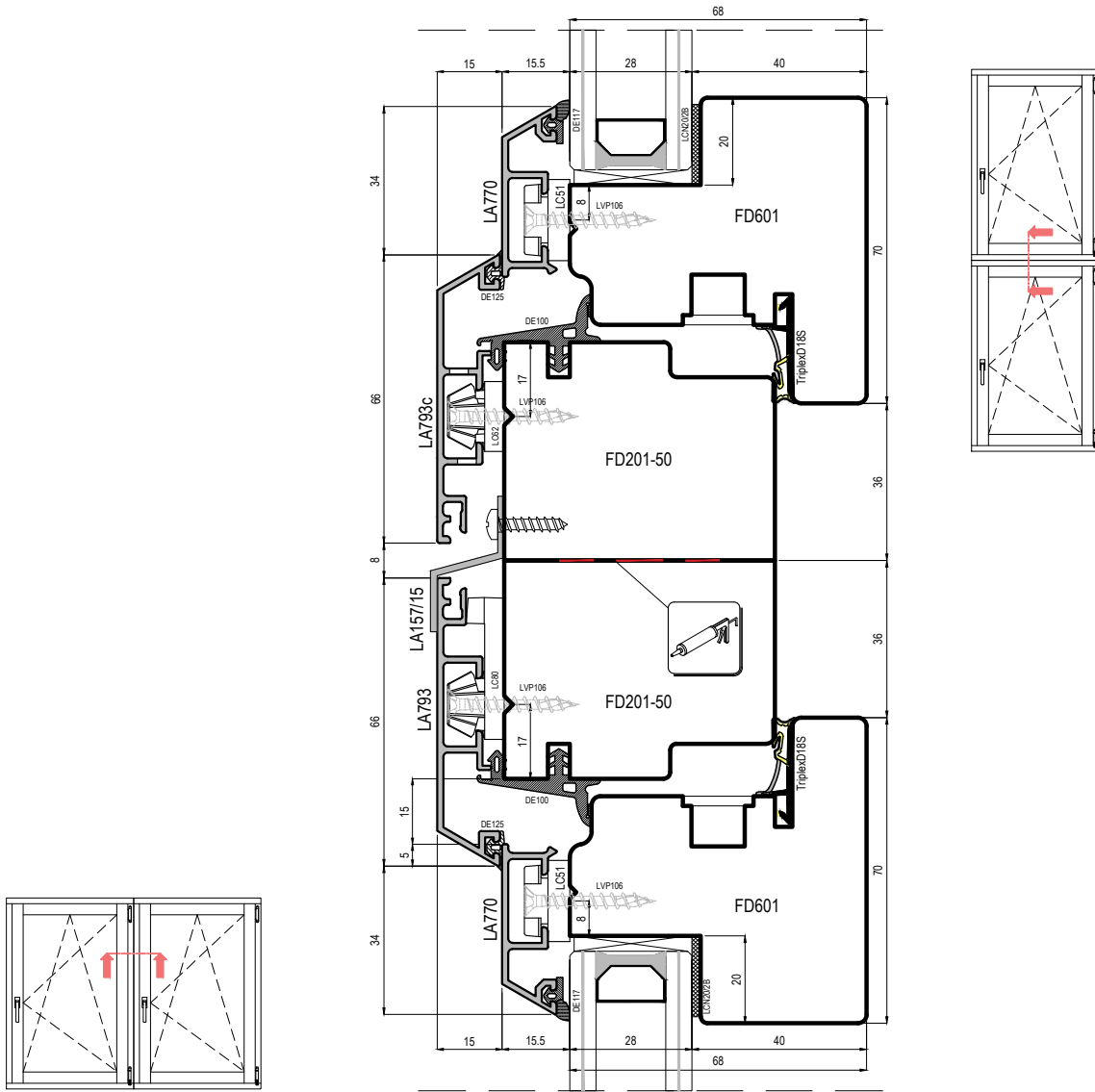

uni_one - Sistema Standard

Scala 0.6:1

CT_uni_one Standard-ver.00/02.24

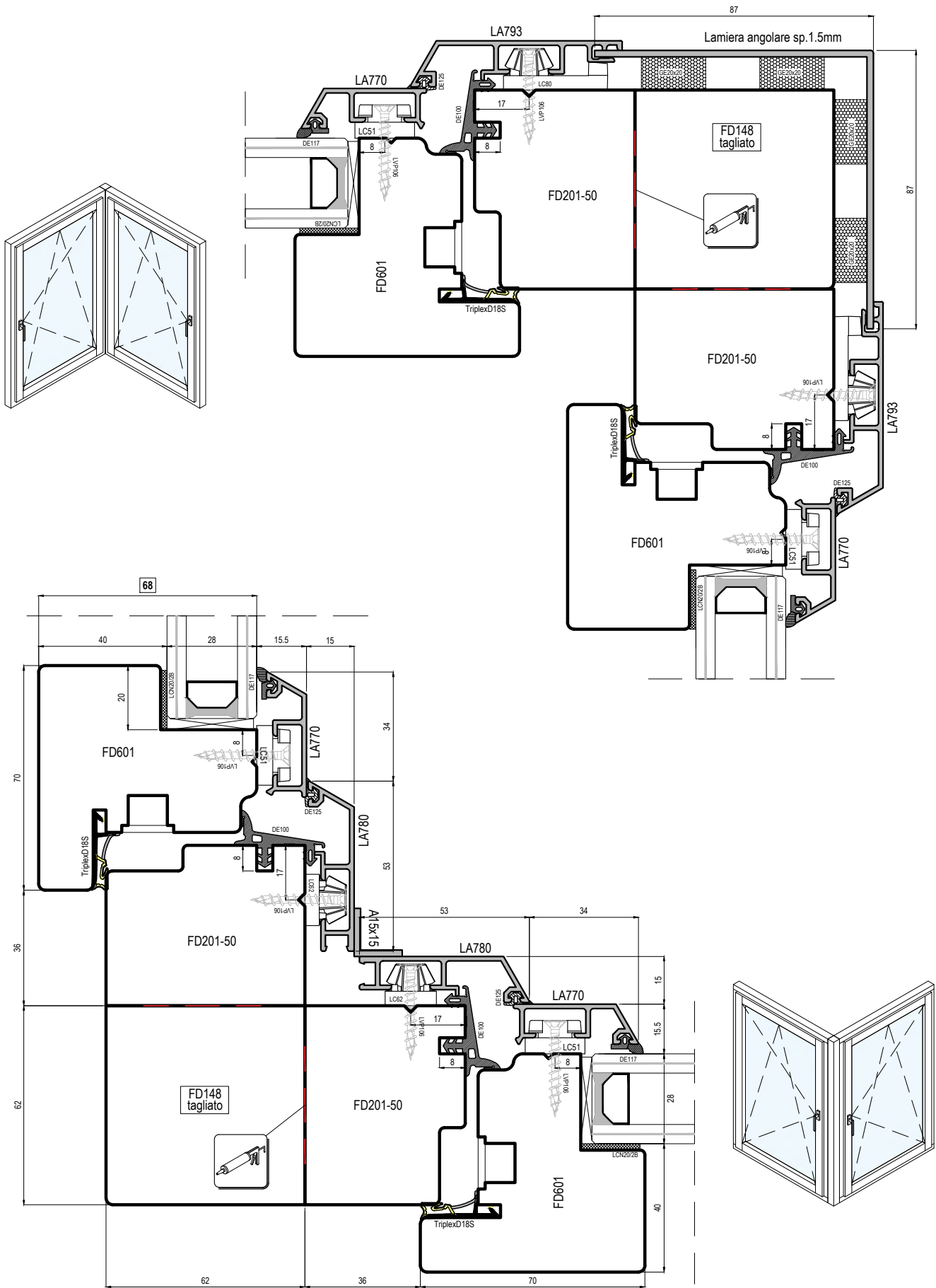

uni_one - Sistema Standard

Scala 0.6:1

CT_uni_one Standard-ver.00/02.24

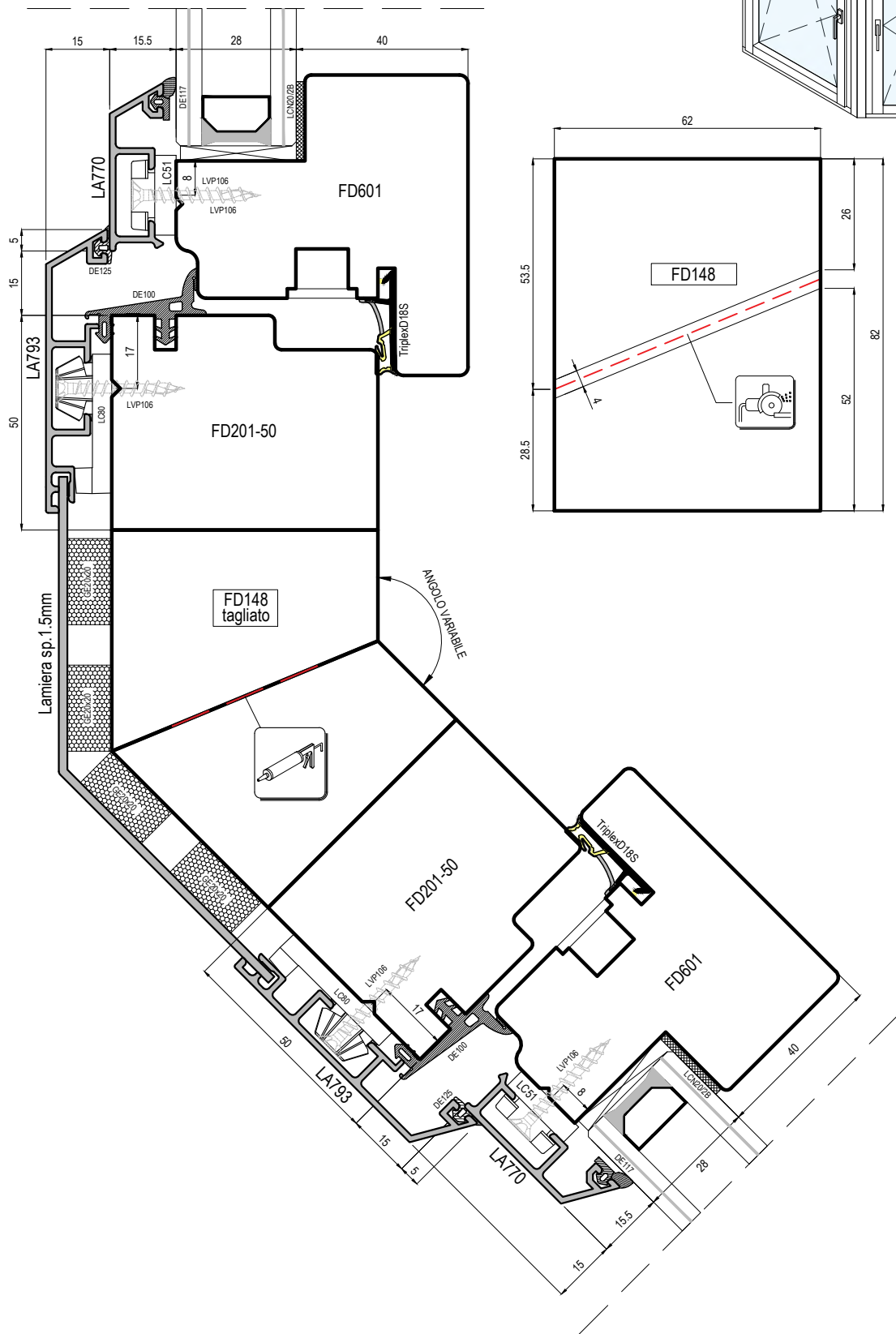

uni_one - Sistema Standard

Scala 0.7:1

CT_uni_one Standard-ver.00/02.24

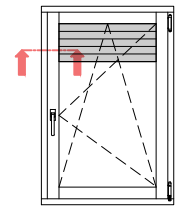
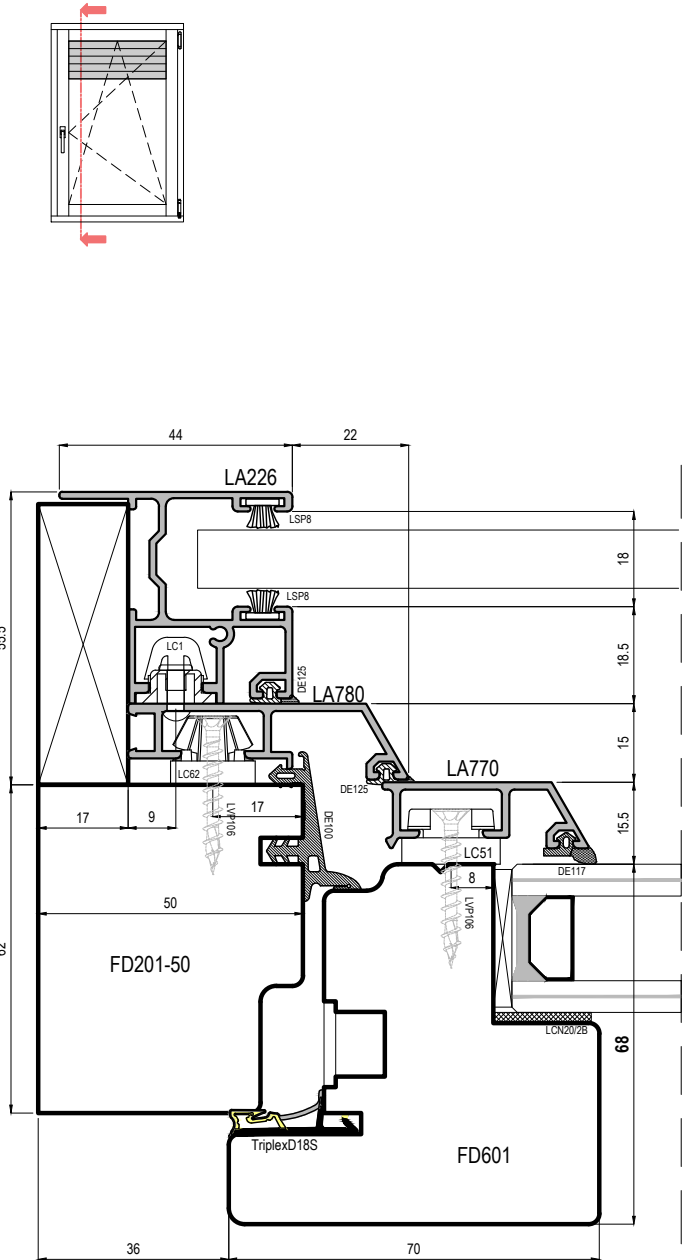
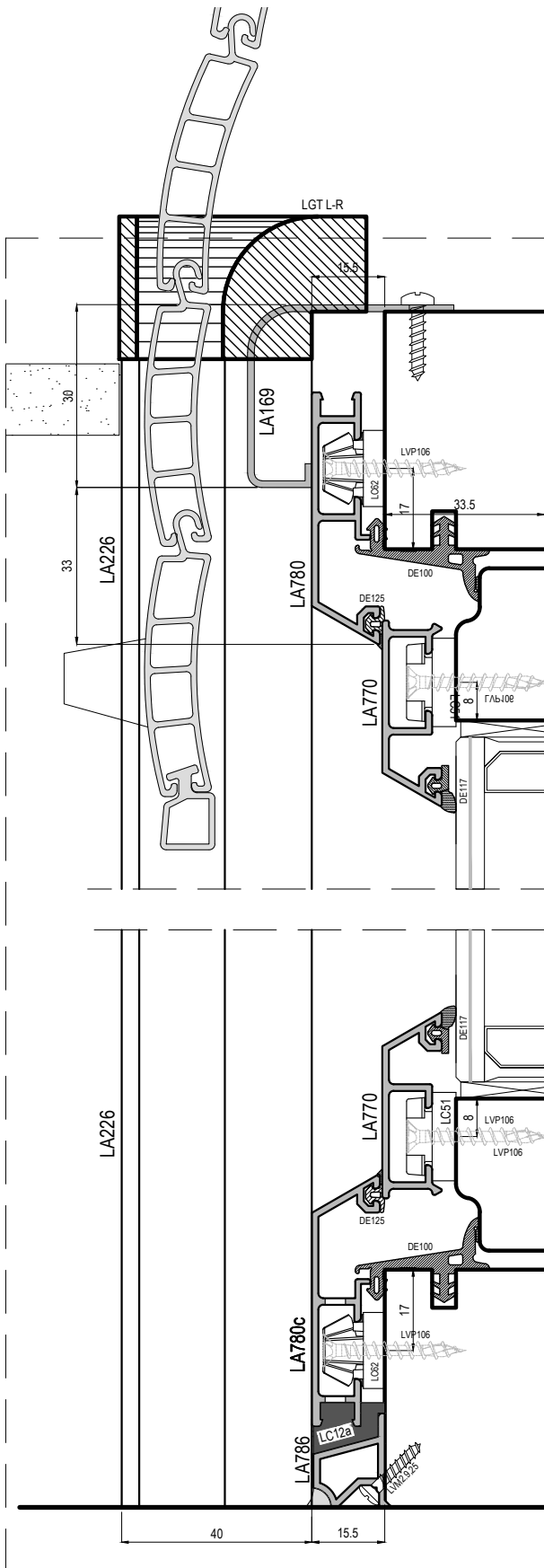

uni_one - Sistema Standard

Scala 0.7:1

CT_uni_one Standard-ver.00/02.24

Produced with:
uni_one
 TECHNOLOGY

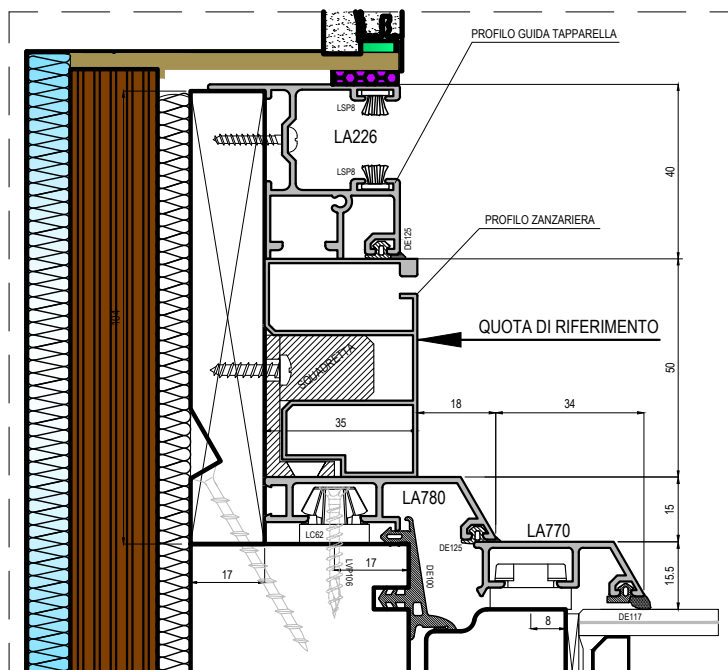
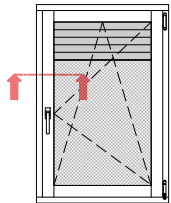
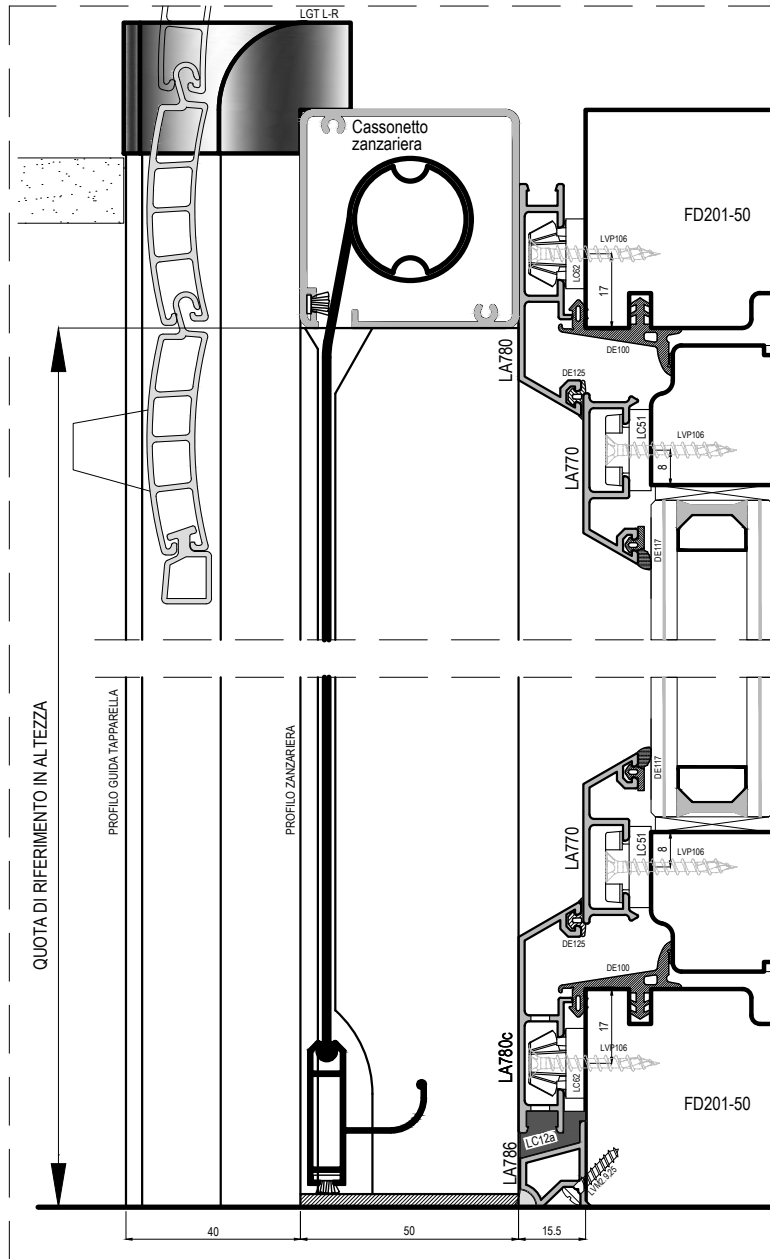
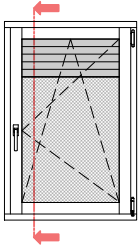

uni_one - Sistema Standard

Scala -

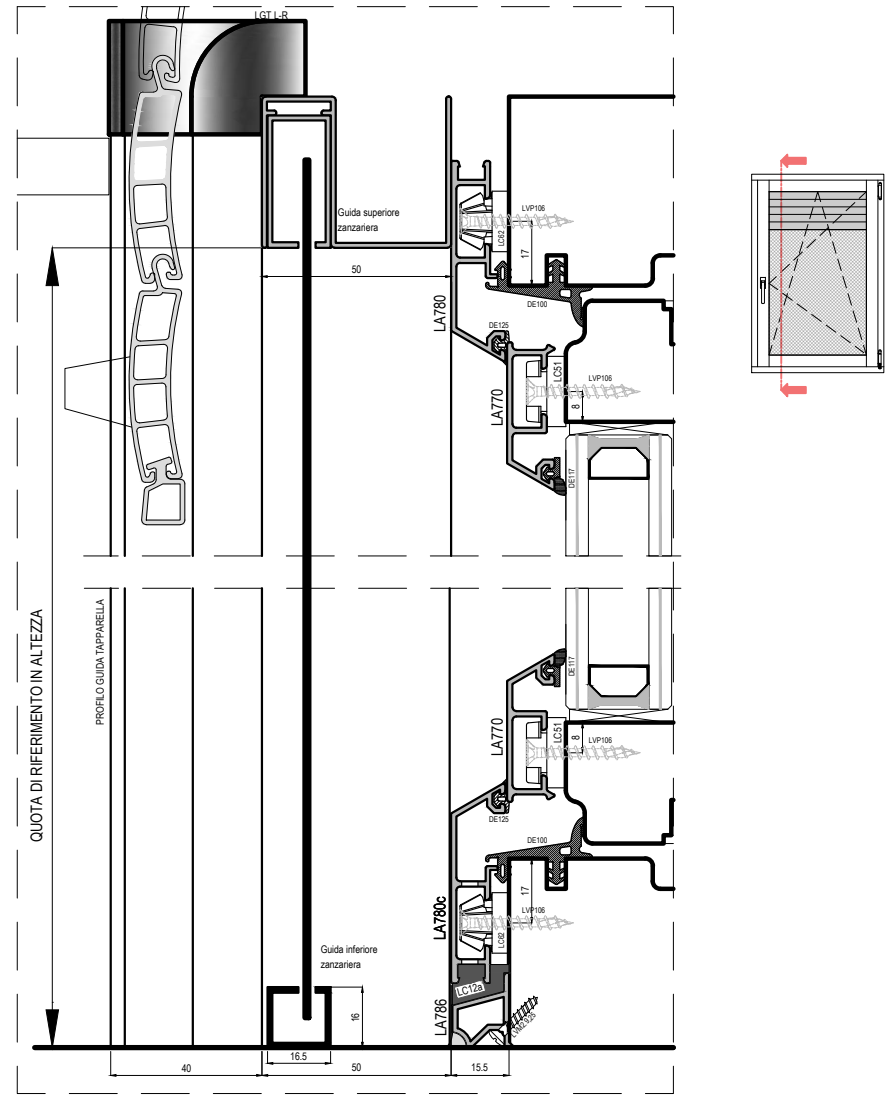
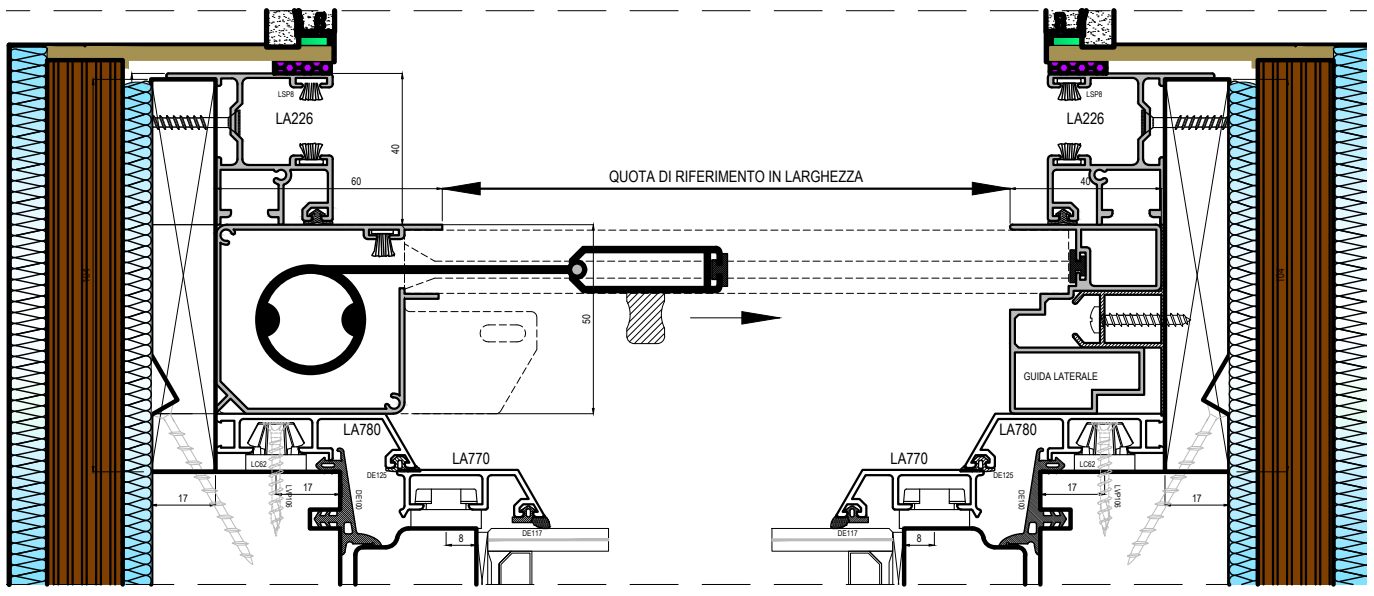
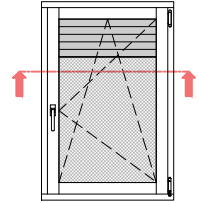

uni_one - Sistema Standard

Scala 1:2

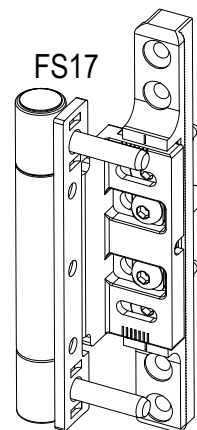
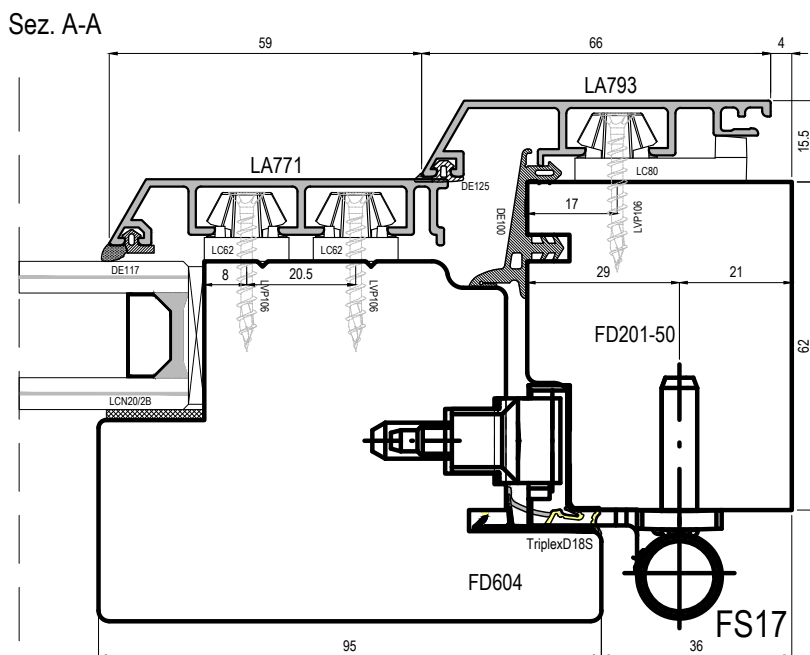
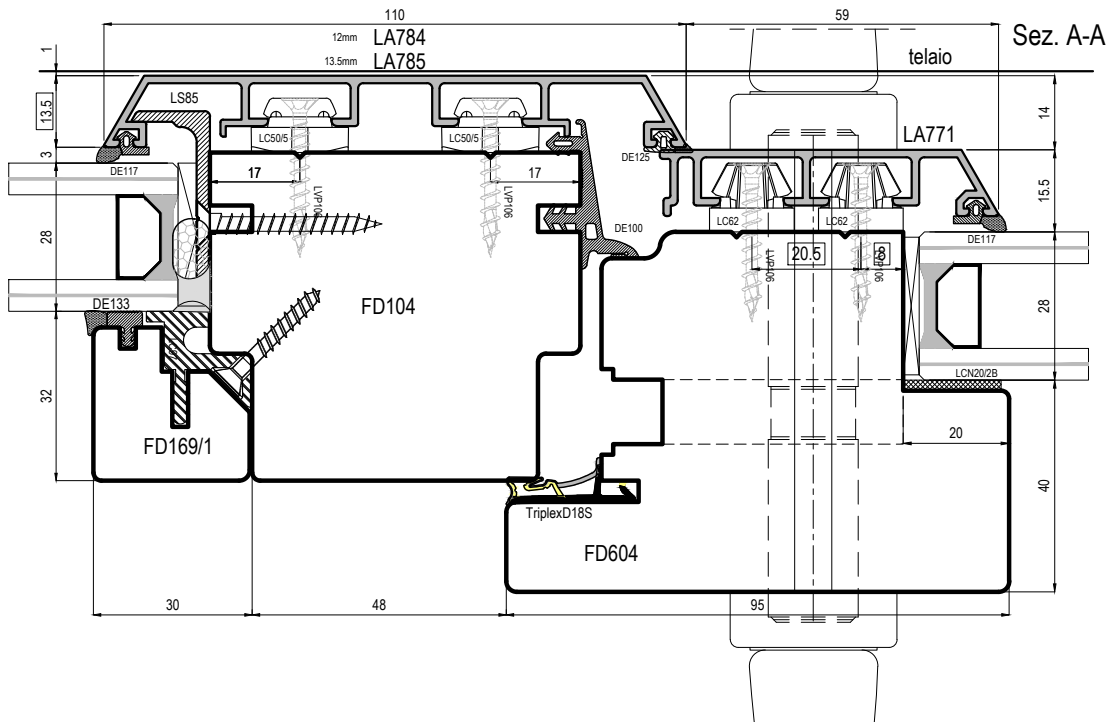
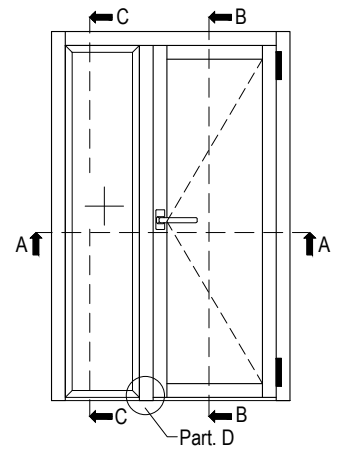
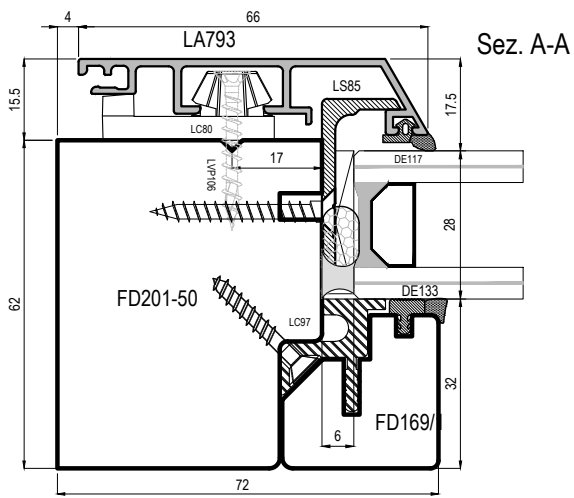

Posizionamento nel caso di terza cerniera

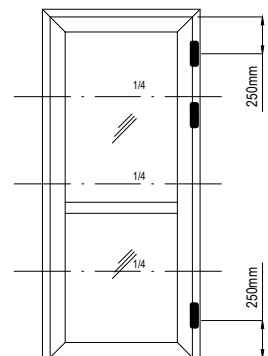

Variante con FS17 (regolabile in 3 direzioni)

- Finiture disponibili:
 Platicato bianco
 Marrone RAL8003
 Marrone scuro RAL8022
 Ottonato
 Cromato opaco
 Bronzo chiaro
 Portata con n°2 cerniere 140Kg

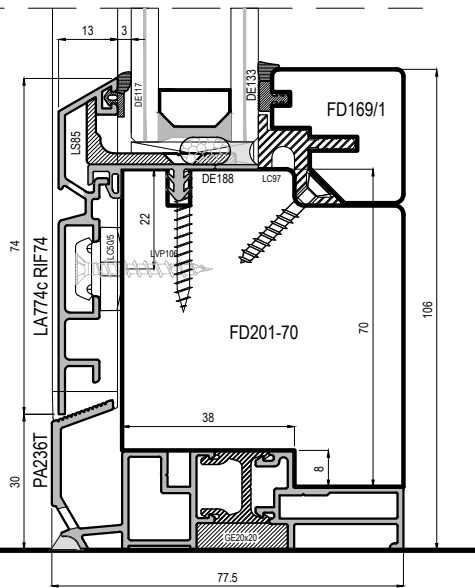
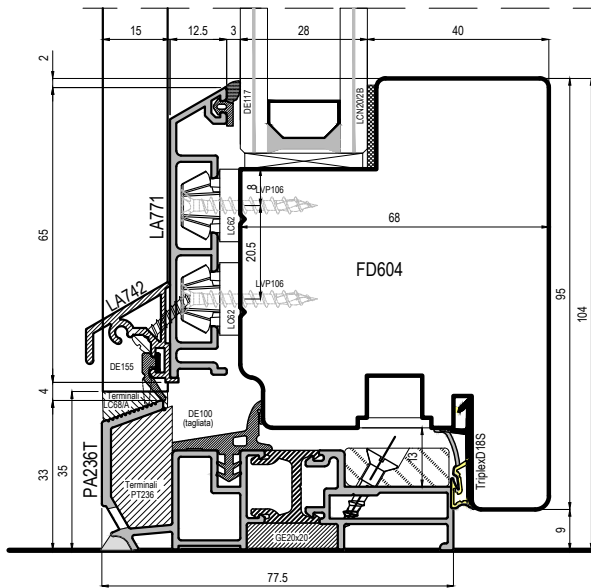
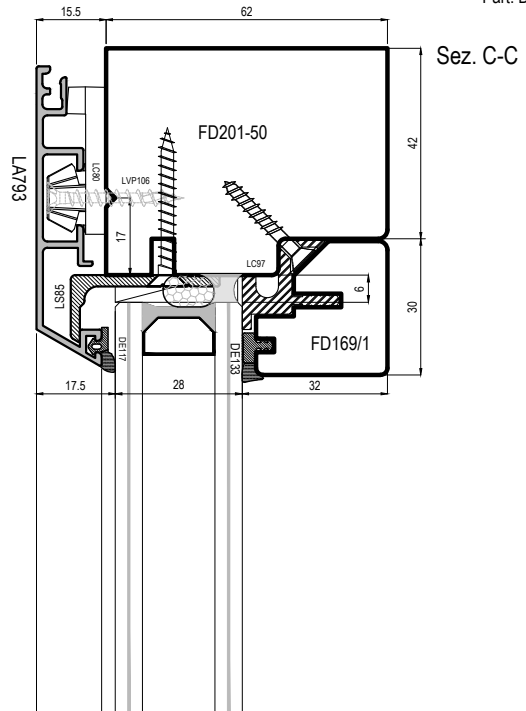
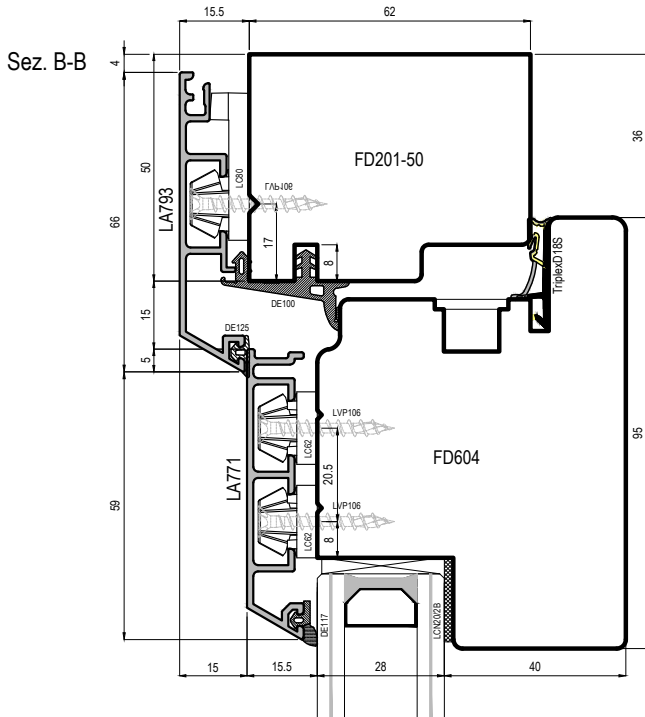
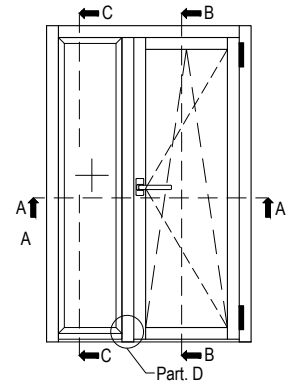
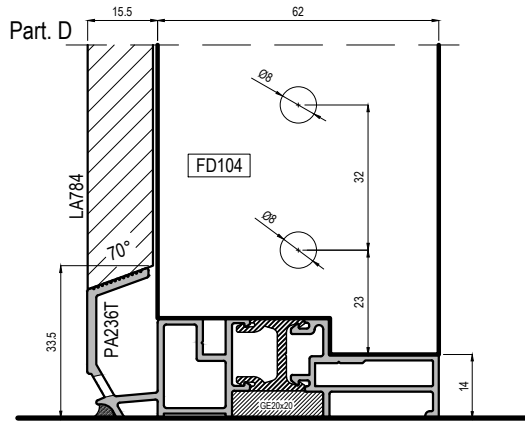

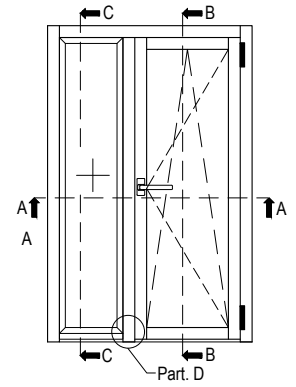
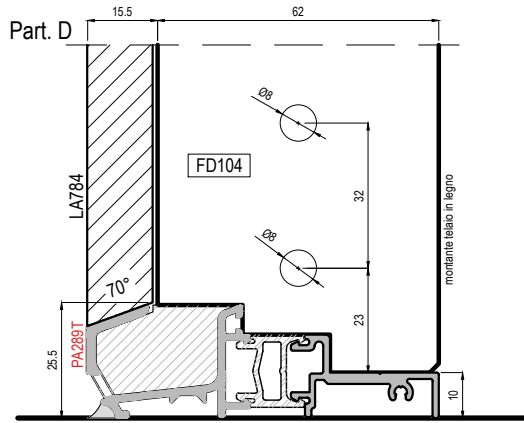

Sez. B-B

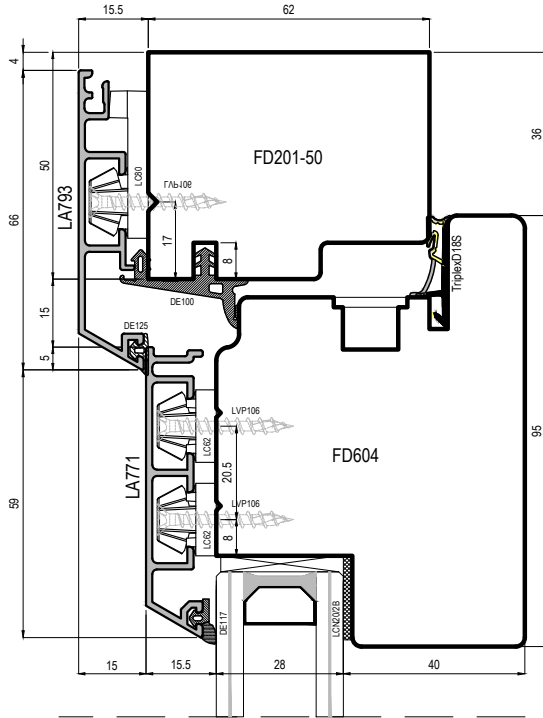

Sez. C-C

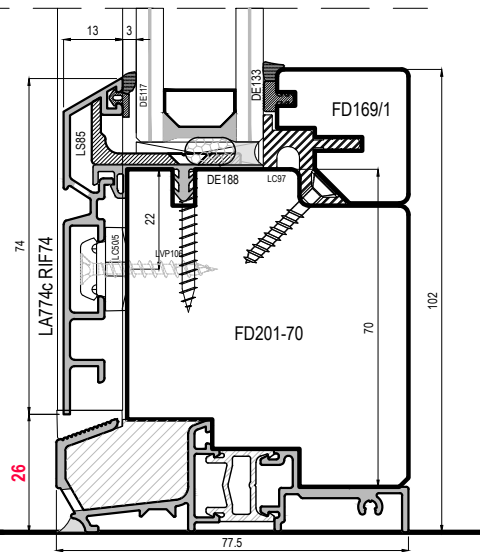
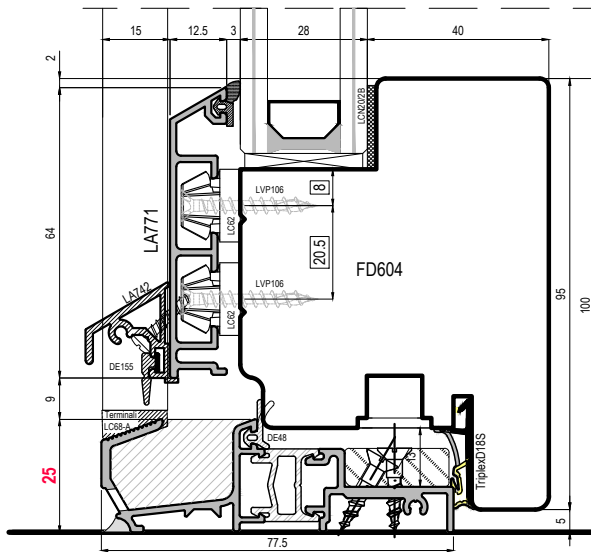
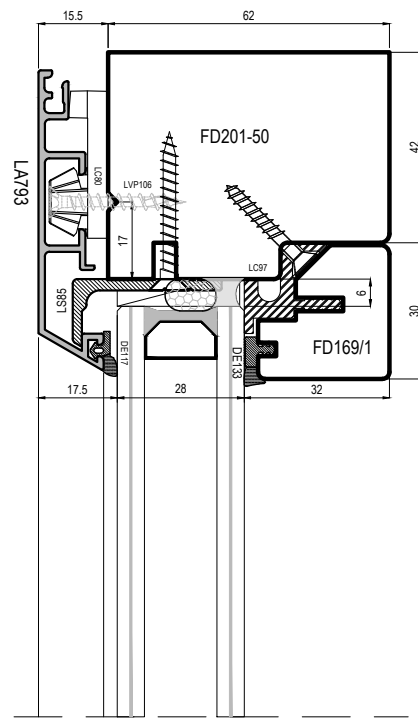

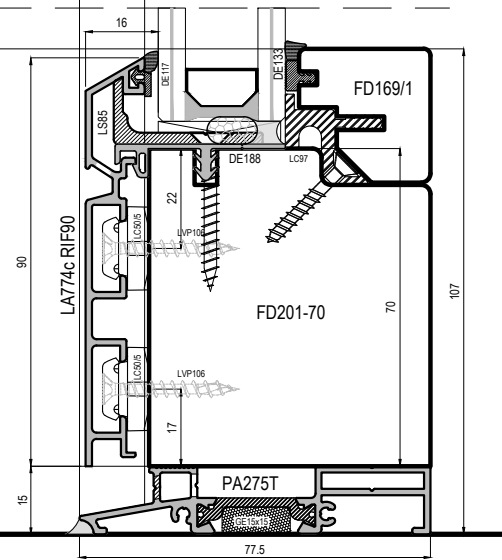
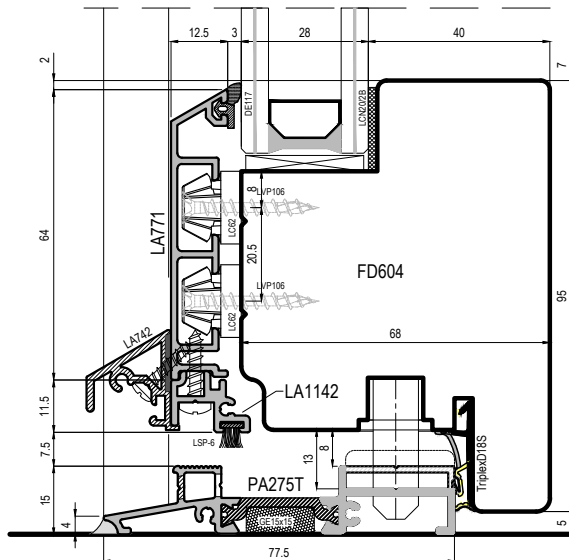
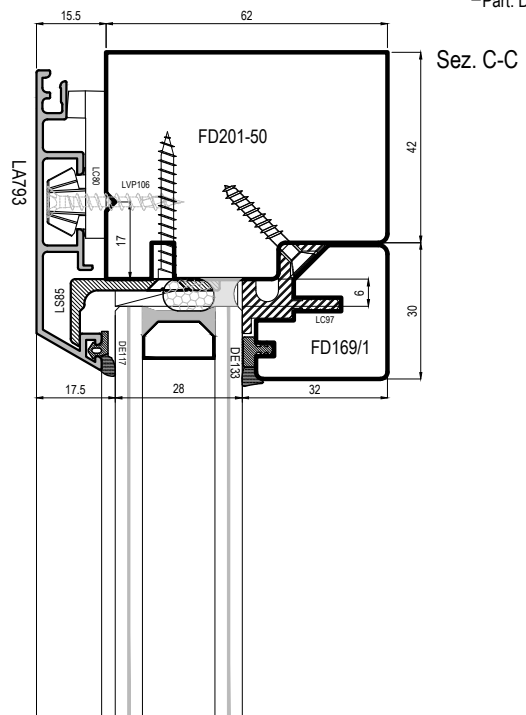
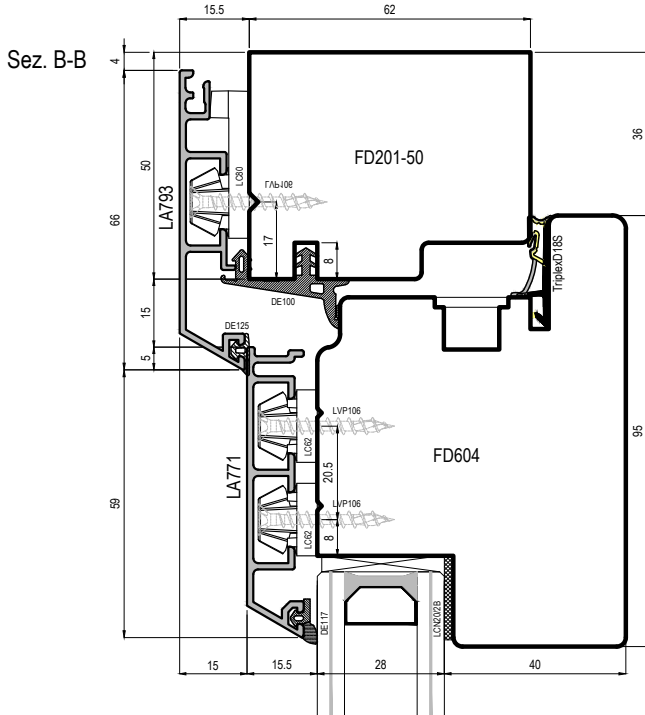
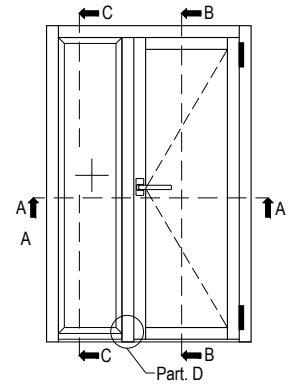
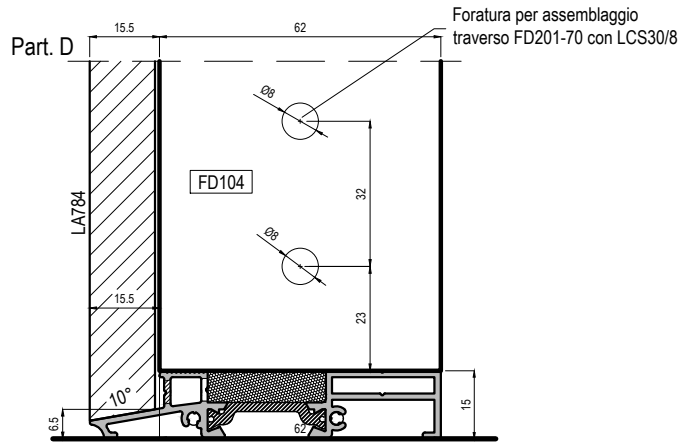

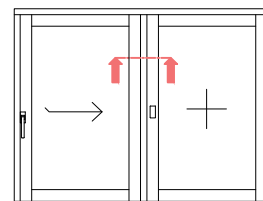
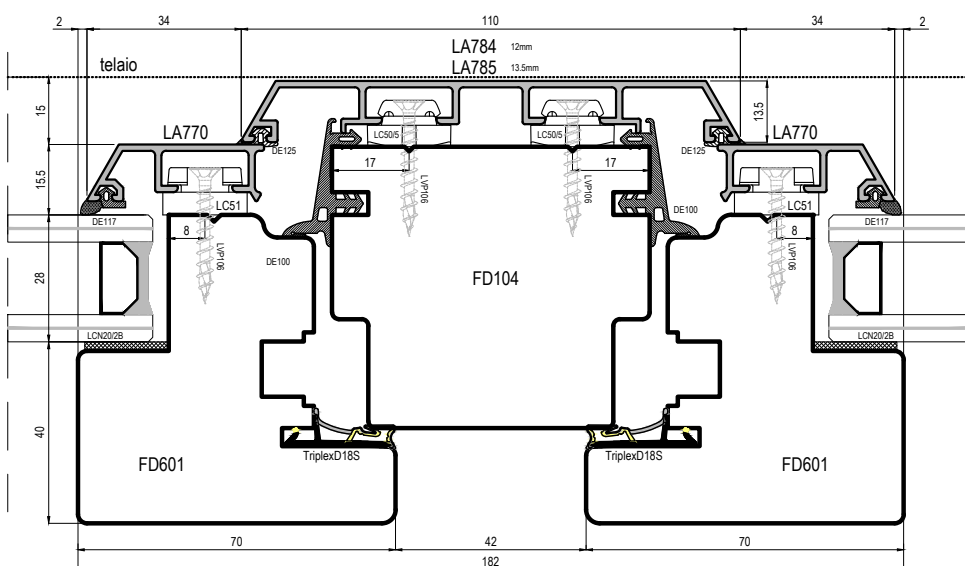
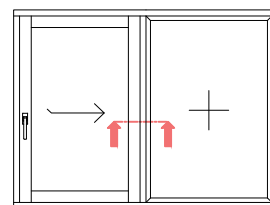
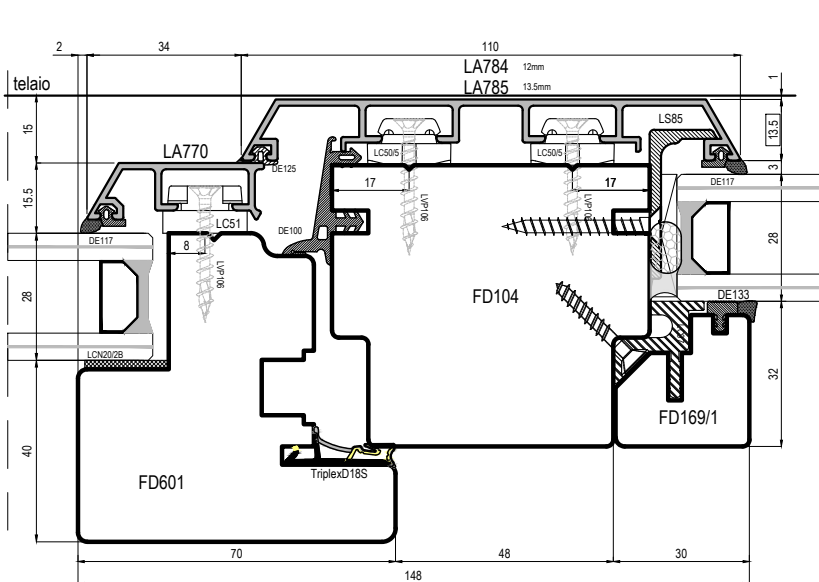
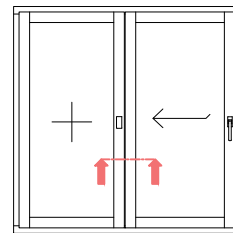
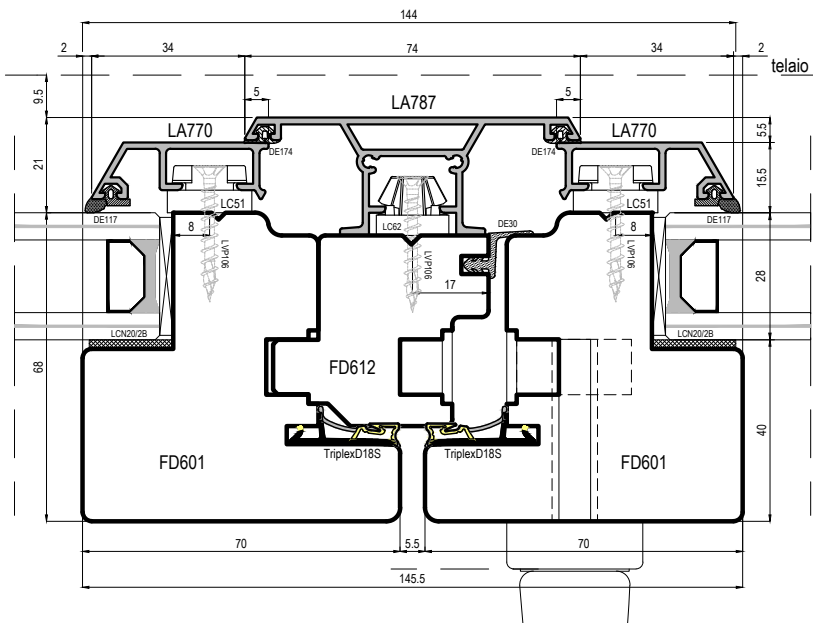

uni_one - Sistema Standard

Scala 0.6:1

CT_uni_one Standard-ver.00/02.24

Produced with:
uni_one
 TECHNOLOGY

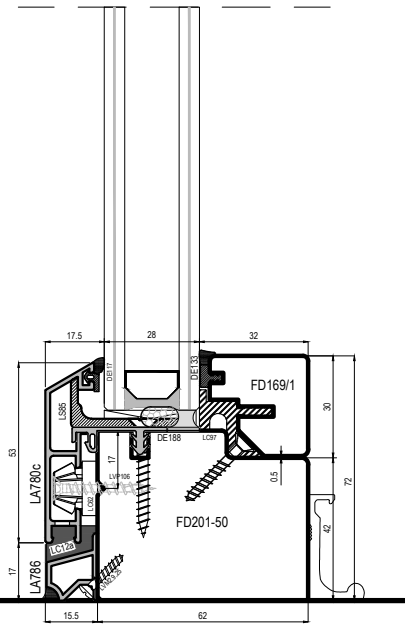
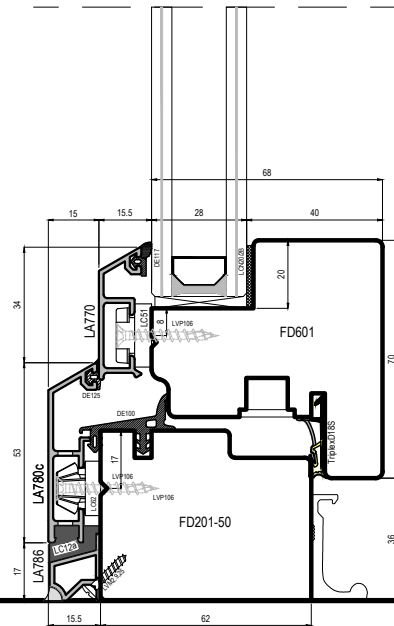
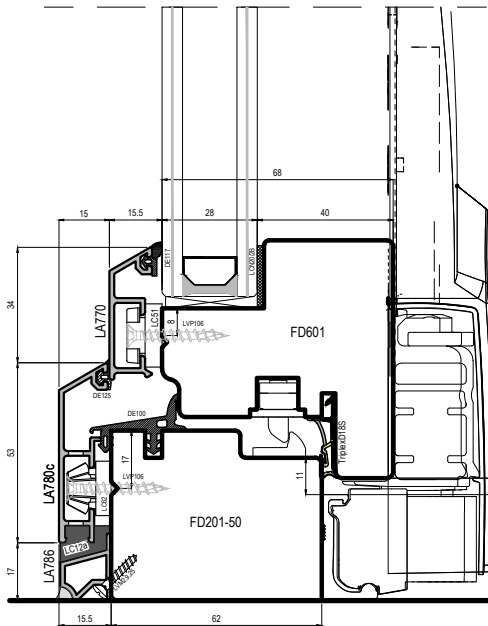
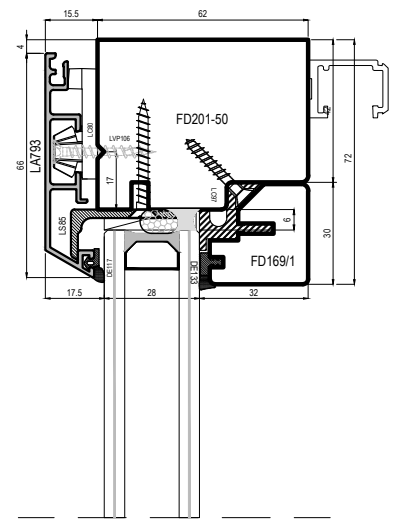
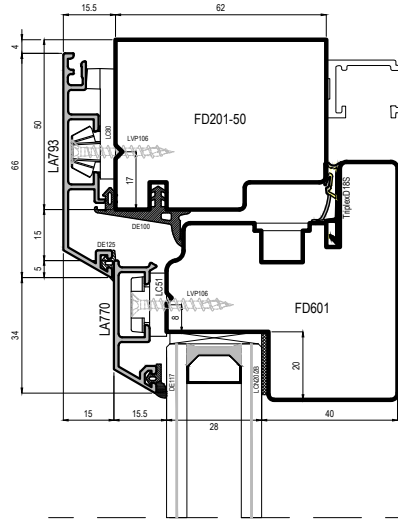
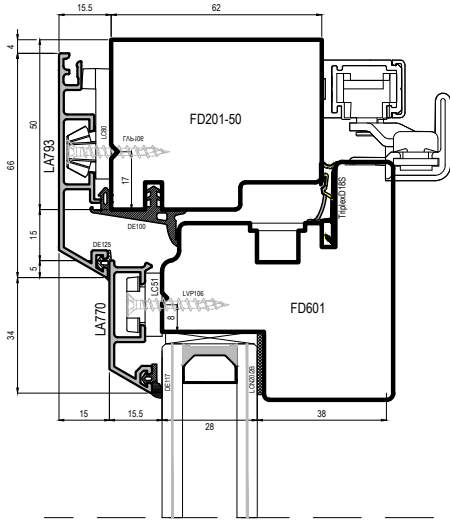
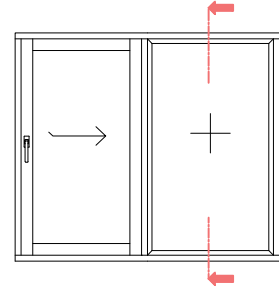
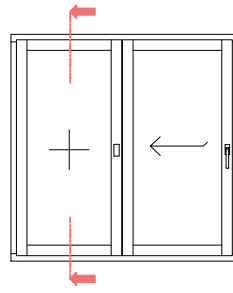
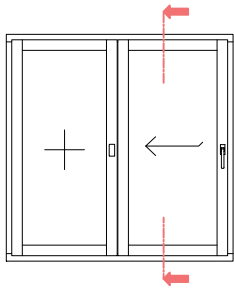

uni_one - Sistema Standard

Scala -

Nell'interesse di un continuo miglioramento dei prodotti, Uniform spa si riserva il diritto di variare le specifiche in qualsiasi momento senza previa notifica.

In the interest of continued improvements to the products, Uniform spa reserve the right to change specifications at any time and without prior notification, and without any obligation