

# COMPLANARE

TRIPLO VETRO / TRIPLE GLAZING

Produced with:  
**uni\_one**  
TECHNOLOGY







*ed. 00/02.2024*

## Indice generale/*General index*

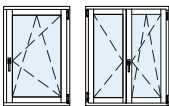
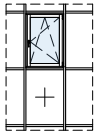
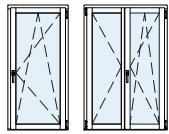
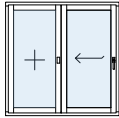
Fattibilità <i>Feasibility</i>	pag.3
Scheda tecnica <i>Technical data sheet</i>	pag.4
Disegni tecnici/ <i>Technical drawings</i> Sezioni finestra <i>Window sections</i>	pag.6
Sezioni scambio battuta centrale <i>Installation examples</i>	pag.9-10
Sezioni porta <i>Door sections</i>	pag.11..16
Traversi intermedi anta e inglesine <i>Intermediate rails and Georgan bars</i>	pag.17..21
Sezione porta con serratura <i>Entrance door</i>	pag.22..29
Finestra con vetro fisso <i>Fixed Light</i>	pag.30..32
Sezioni montanti e traversi intermedi telaio <i>Frame transom and mullion</i>	pag.33..35
Telai per ristrutturazione FD305-FD312 <i>Wooden frames profiles for renovation</i>	pag.36..38
Sezioni bugna/pannelli <i>Ashlar panels</i>	pag.39-40
Finestre accoppiate <i>Connected windows</i>	pag.41..43
Sezioni finestra con tapparella <i>Roller Shutter</i>	pag.44
Sezioni finestra con zanzariera <i>Mosquito net</i>	pag.45-46
Sezioni porta d'ingresso con fisso laterale <i>Entrance door with fixed light</i>	pag.45..50
Sezioni Scorrevole complanare <i>Coplanar sliding window/door</i>	pag.51-52

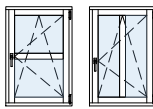
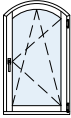
## Esempio di principali tipologie realizzabili

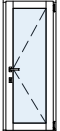
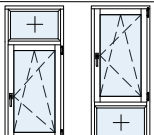
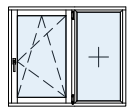
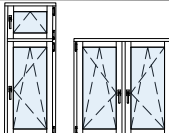
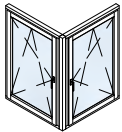
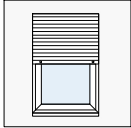
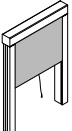
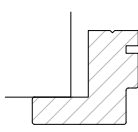
I)Finestra A/R D)Flügel E)Ventana F)Fenêtre EN)Window		✓	I)Inserimento in facciata D)Einspannelement für Fassade E)Encaje en fachada F)Prédisposition pour l'insertion en façade EN)Insertion window for curtain wall		⊘
I)Portafinestra A/R D)Tür E)Puerta ventana F)Porte fenêtre EN)Window door		✓	I)Scorrevole parallelo D)Paralle-Schiebefenster E)Corredera paralela F)Coulissant parallèle EN)Parallel-sliding windows		✓
I)Finestra con anta fissa/Finestra con vetro fisso D)Fenster mit Fixverglasung E)Ventana con cristal fijo F)Fenêtre avec vitre fixe EN)Fixed Light		✓	I)Fuorisquadra D)Schrägelement E)Fuera de squadra F)Hors-équerre EN)Shaped window		⊘
I)Traverso intermedio anta D)Sprossen in Flügel E)Travesanos intermedios de la hoja F)Traverses intermédiaires vantail EN)Sash intermediate rails		✓	I)Serramento ad arco D)Rundbogenfenster E)Cerramiento curvado F)Châssis cintré EN)Curved window		⊘
I)Inglesine(con incollaggio al vetro) D)Vorsatzsprosse E)Travesanos F)Traverses EN)Georgian bars		✓	I)Serramento ad impacchettamento(Libro) D)Falttür E)Cerramiento a libro F)Coulissante pliante EN)Sliding folding window		⊘
I)Porta con serratura D)Tür mit schloss E)Puerta con cerradura F)Porte avec serrure EN)Window door with lock		✓			
I)Finestra con sopra/sottoluce fisso D)Fenster mit Ober/Unterlicht fix E)Ventana con sobreluz/antepecho fijo F)Fenêtre avec partie fixe EN)Fixed glazing		✓			
I)Finestra con fisso laterale D)Fenster mit seitlichen Fixelement E)Ventana con fijo lateral F)Fenêtre avec fixe latéral EN)Side-fixed glazing		✓			
I)Piantoni e traversi intermedi telaio D)Rahmen mit Kämpfer und Setzholz E)Montantes y travesaños intermedios marco F)Meneaux et traverses intermédiaires dormant EN)Sash intermediate mullions and transoms		✓			
I)Finestre accoppiate D)Gekoppelte Fenster E)Ventanas acopladas F)Fenêtres assemblées EN)Connection between windows		✓			
I)Inserimento per tapparelle D)Rolladenführungsprofile E)Encaje para celosías F)Prédisposition pour volets roulants EN)Arrangement for roller shutters		✓			
I)Inserimento zanzariere D)Einführung Fliegengitter E)Encaje para mosquiteras F)Prédisposition pour moustiquaires EN)Arrangement for fly screens		✓			
I)Telaio per ristrutturazione D)Rahmen für Renovierung E)Marco para rehabilitación F)Cadre pour rénovation EN)Frame for renovation		✓			

Per i limiti dimensionali, di portata e di fattibilità delle ante fare riferimento ai cataloghi tecnici del proprio fornitore di ferramenta.  
*Please refer to your hardware supplier's technical catalogues for sash size, load-bearing capacity and feasibility limits.*

# COMPLANARE

TRIPLO VETRO **U<sub>w</sub>=0,8 W/m<sup>2</sup>K**



<b>Materiale</b>		Legno-Alluminio
<b>Isolamento termico</b>		U <sub>w</sub> = 0,8 W/m <sup>2</sup> K
<b>Vetrocamera</b>		Tripla vetro spessore 44mm
<b>Isolamento acustico</b>		R <sub>w</sub> fino a 43 dB
<b>Ferramenta di sicurezza</b>		Fino a RC2
<b>Dimensioni in mm.</b>		
Spessore anta		98,5 x 70mm
Spessore telaio		77,5 x 72,5mm
Sezione a vista anta + telaio		106mm
Sezione a vista nodo a 2 ante		116mm
<b>Permeabilità all'Aria</b>		CLASSE 4
<b>Tenuta all'Acqua</b>		CLASSE E1350
<b>Resistenza al carico del Vento</b>		CLASSE C5

I valori di isolamento termico sono calcolati secondo la norma UNI EN 10077/1-2018, UNI EN 10077/2-2018, UNI EN 10456-2008, UNI EN 673-2011, in riferimento ad un serramento a 1 anta LxH (1230x1480mm, ψ<sub>g</sub> = 0,04 W/mK)

Le prestazioni aria-acqua-vento sono certificate in riferimento ad un serramento a 2 ante LxH (1500x1500mm)

I valori di isolamento acustico sono certificati in riferimento ad un serramento a 1 anta LxH (1230x1480mm)

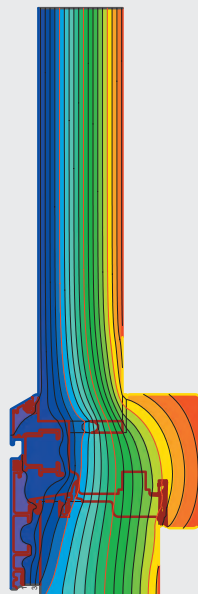

**COMPLANARE - vetro 44mm  
LEGNO TENERO (SOFT WOOD)  
U<sub>f</sub> = 1,3 W/m<sup>2</sup>K**

U <sub>g</sub> W/m <sup>2</sup> K	U <sub>w</sub> W/m <sup>2</sup> K
0,5	-> 0,8
0,6	-> 0,9
0,7	-> 1,0
0,8	-> 1,0
0,9	-> 1,1
1,0	-> 1,2
1,1	-> 1,3

**Tavole tecniche**  
***Technical Drawings***

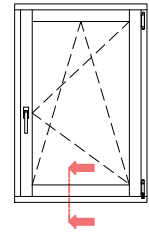

Tagliare seguendo l'incisione con forbice LF1



Finitura Codice biadesivo  
 ICONA: LCN20-2B  
 NATURA: LCN20-2BT

VARIANTI SCARICHI ACQUA FRONTALI

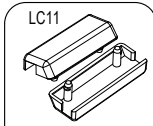

LC11  
 Colore: BIANCO / NERO  
 Materiale: ABS

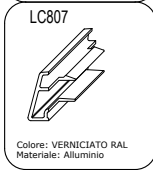

LC807  
 Colore: VERNICIATO RAL  
 Materiale: Alluminio

Profilo per telai assemblati  
 Profile for assembled frames

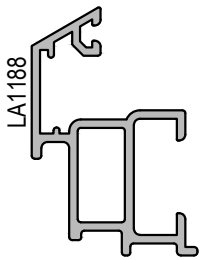

Profilo per telai saldati  
 Profile for welded frames

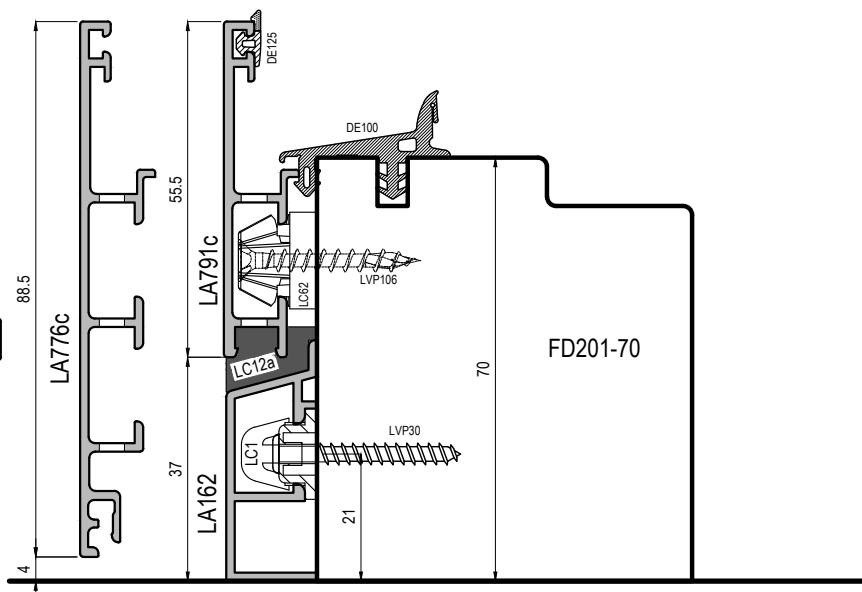
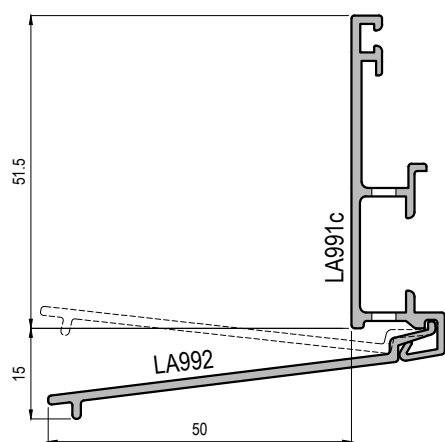
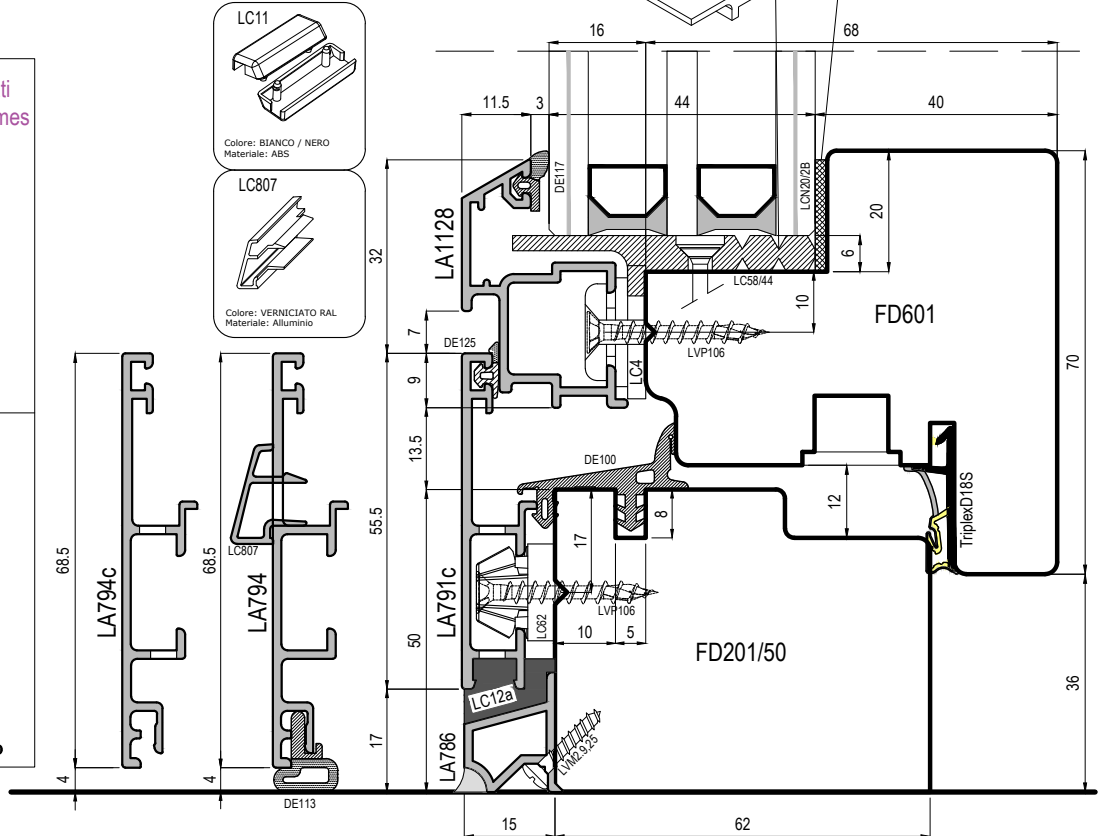
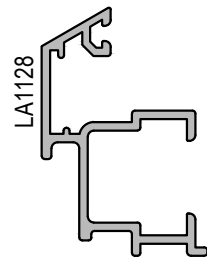

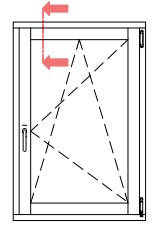
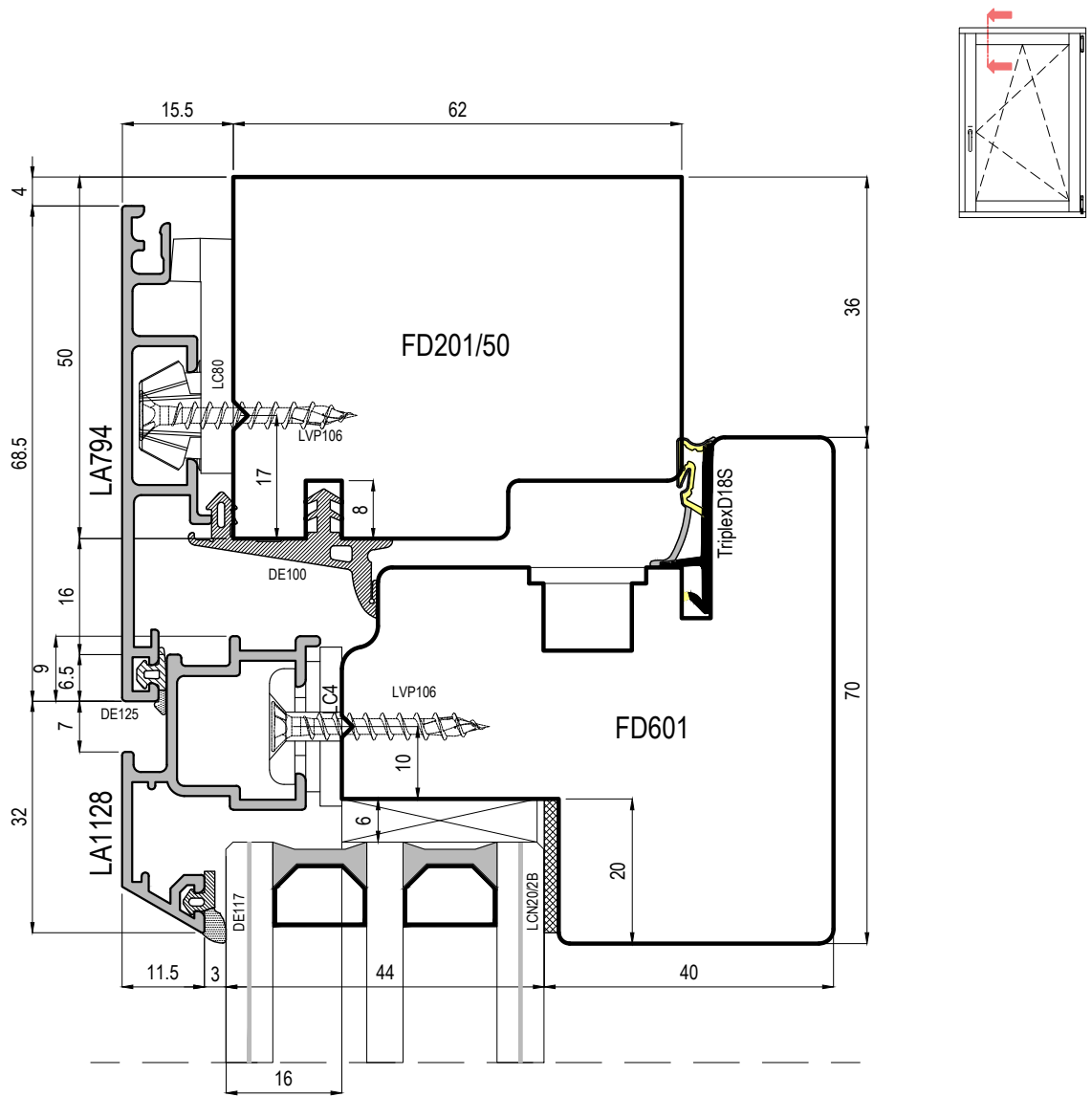

Coprifili in legno

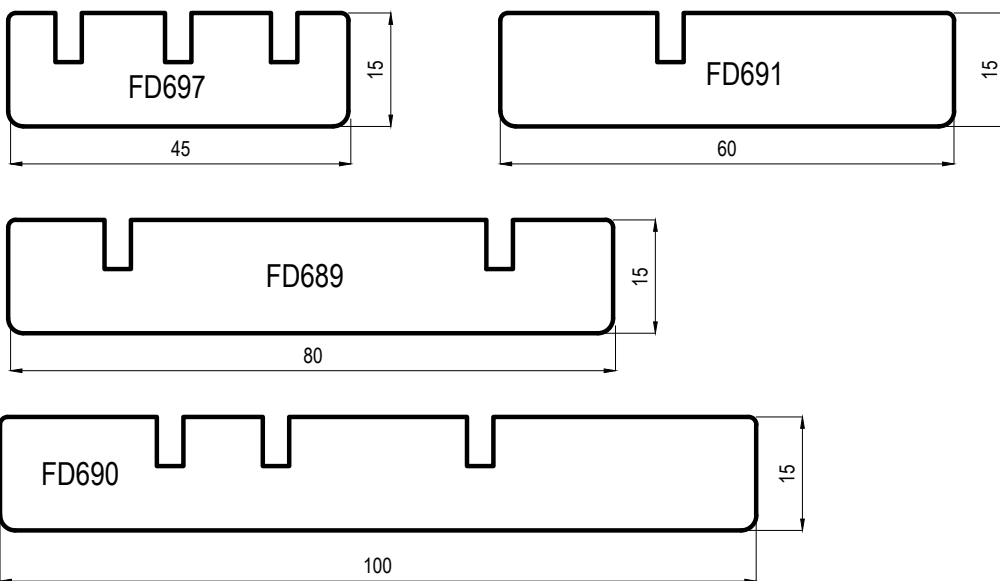

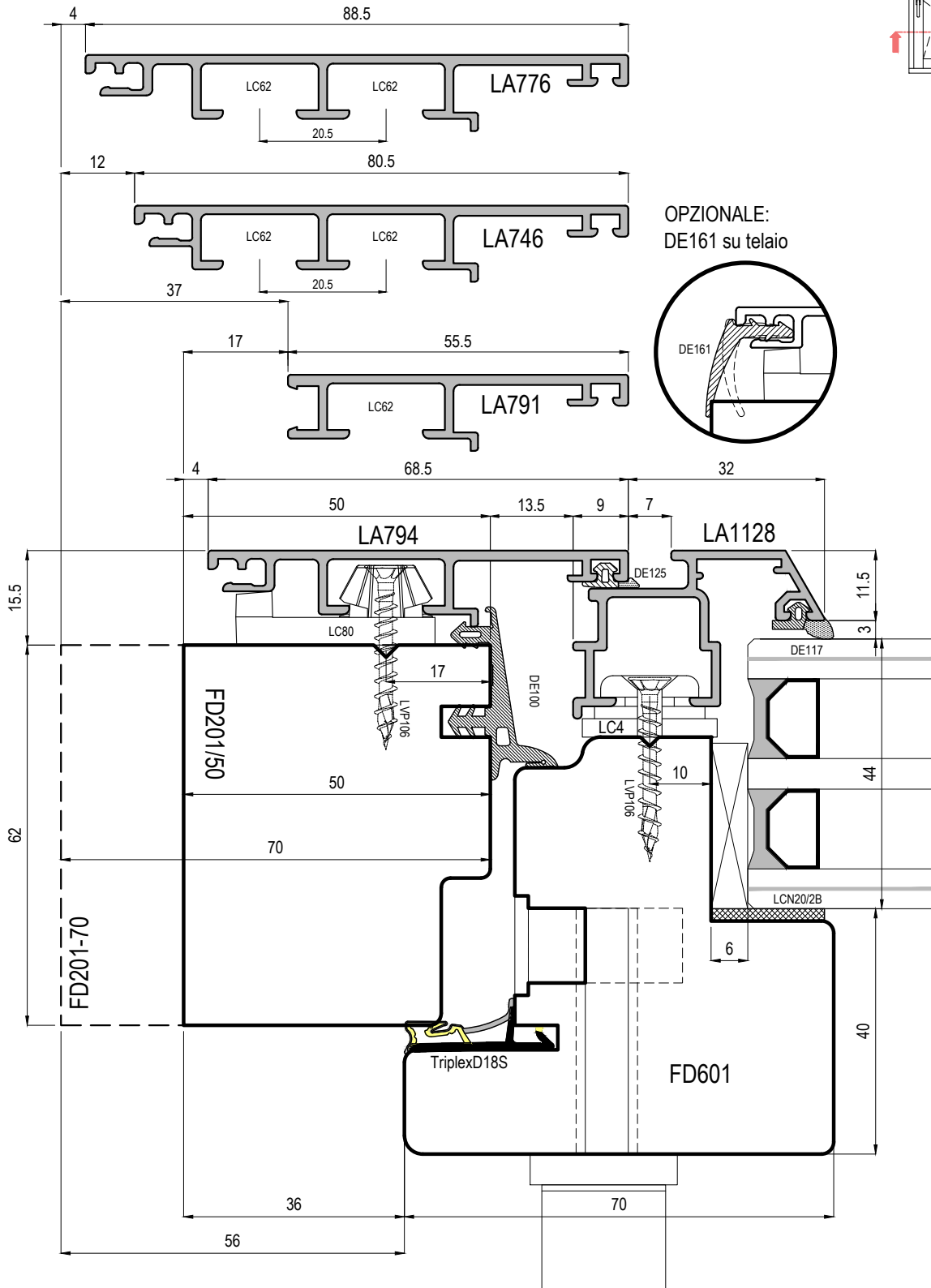
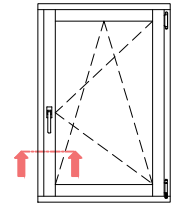

OPZIONALE:  
DE161 su telaio

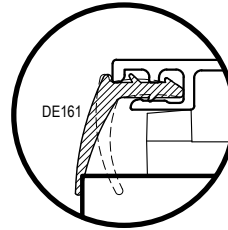



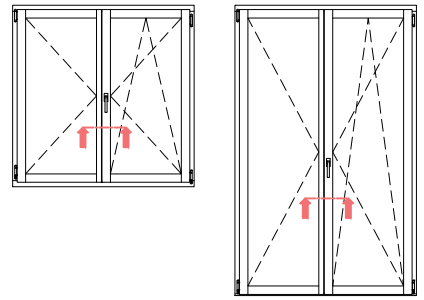
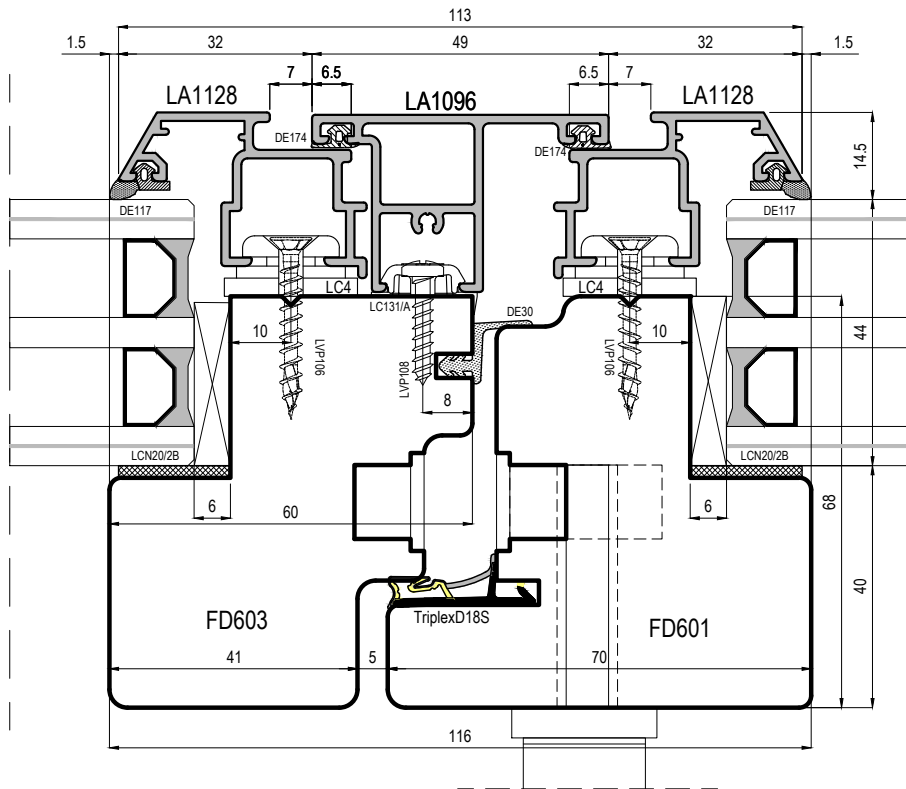

Coppia terminali  
aggiuntivi per  
porta:  
LC1096/P

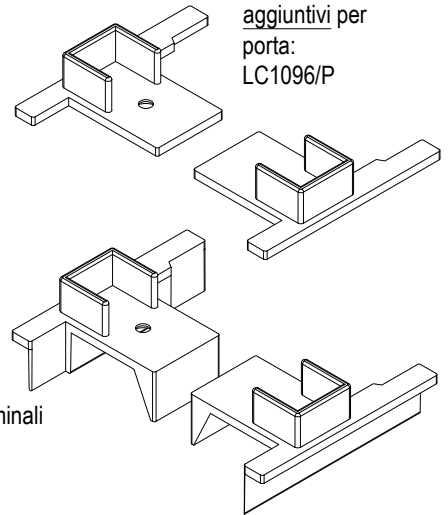

Coppia terminali  
LC1096

Sezione chiusura centrale porta

IMPORTANTE: Fissare  
il terminale superiore  
per bloccare lo  
scorrimento del  
profilo LA1095

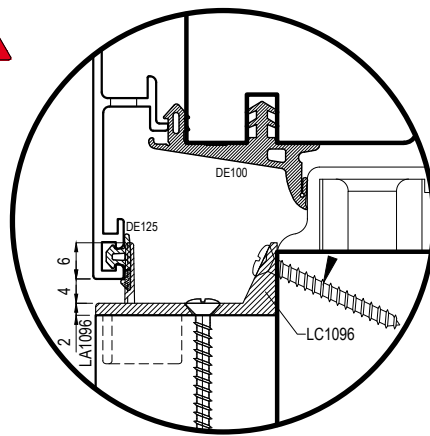
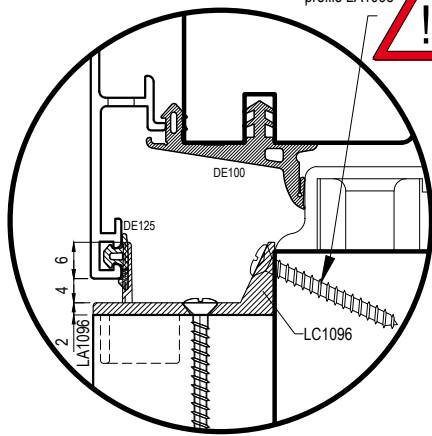

Sezione chiusura centrale finestra

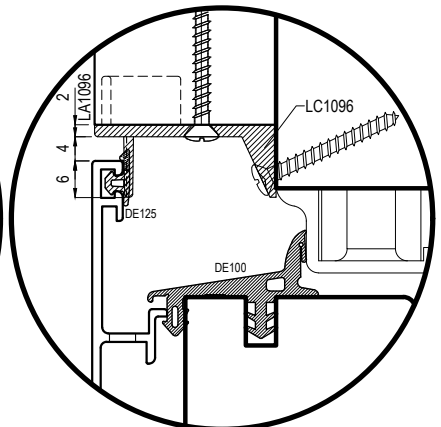
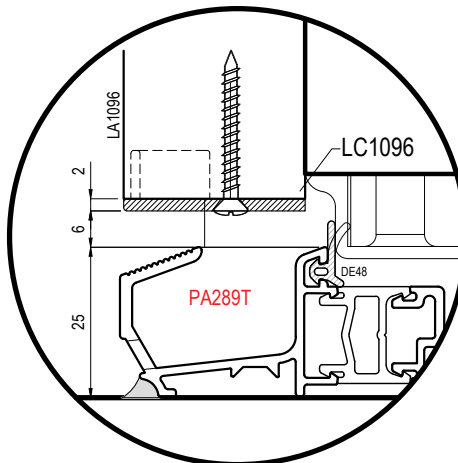
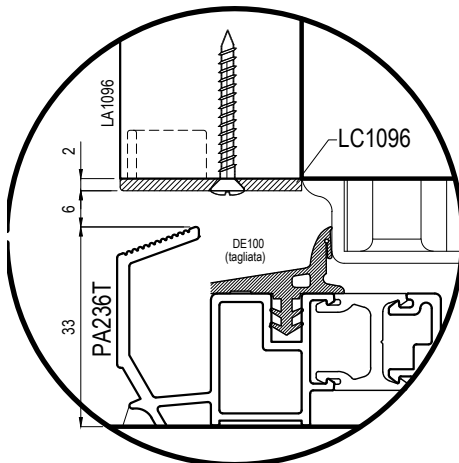
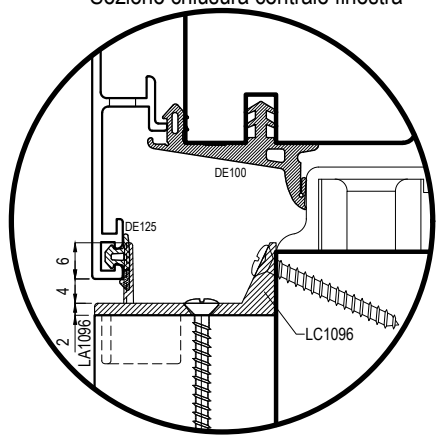

uni\_one - Sistema Complanare

Scala 0.8:1

Produced with:  
**uni\_one**  
TECHNOLOGY

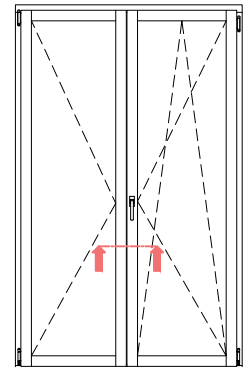
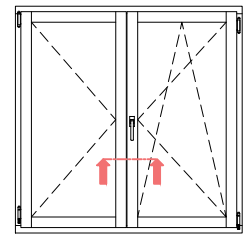
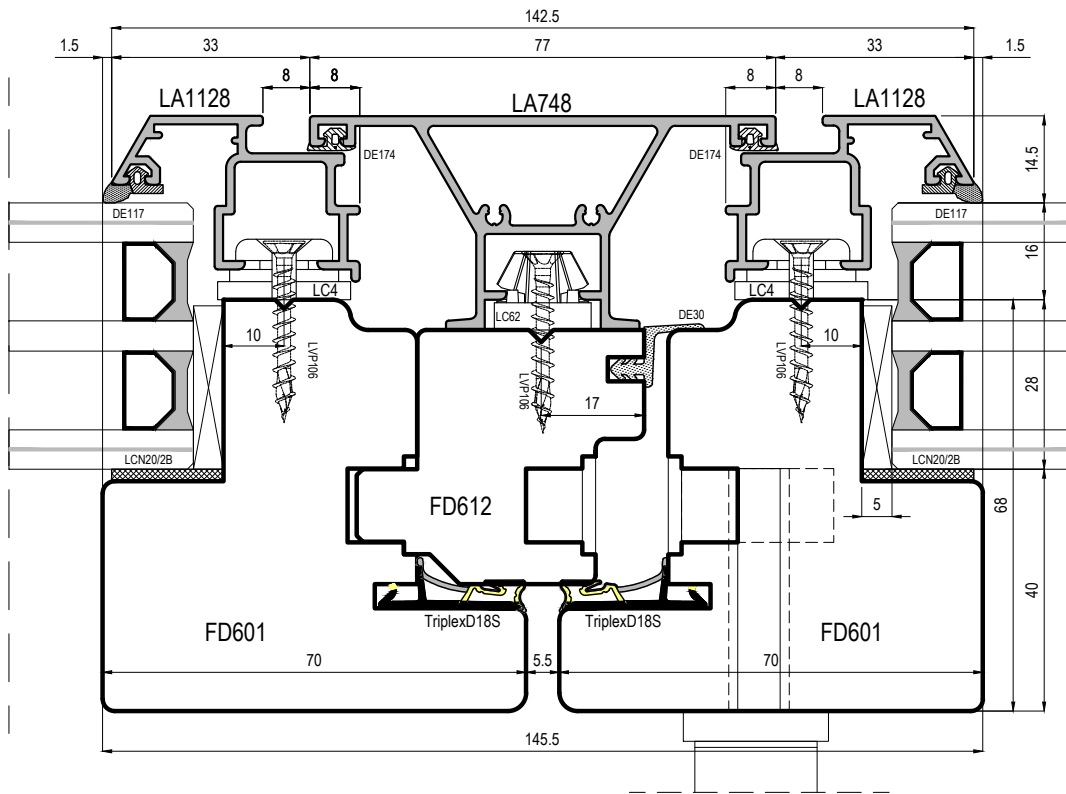

Sezione chiusura centrale porta

IMPORTANTE: Fissare il terminale superiore per bloccare lo scorrimento del profilo LA1095

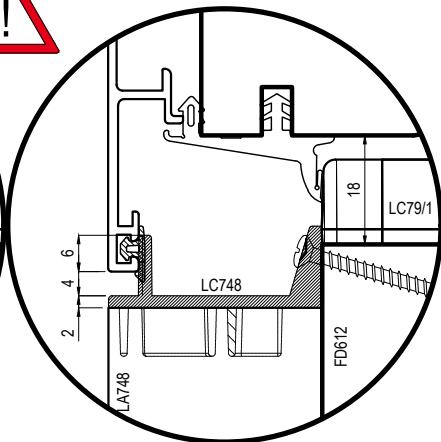
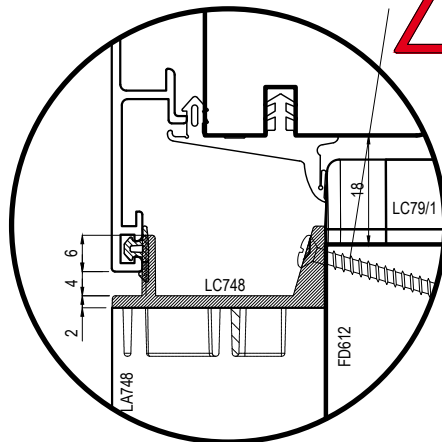

Sezione chiusura centrale finestra

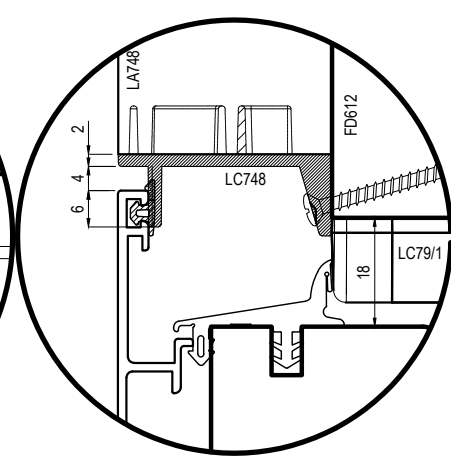
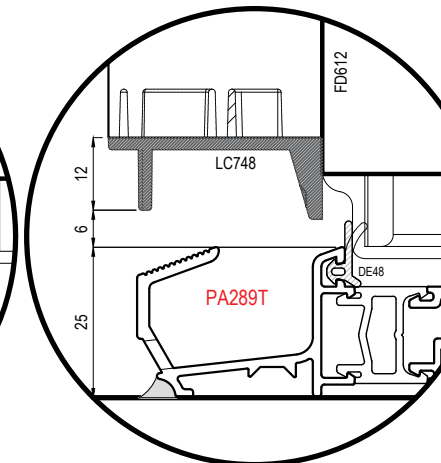
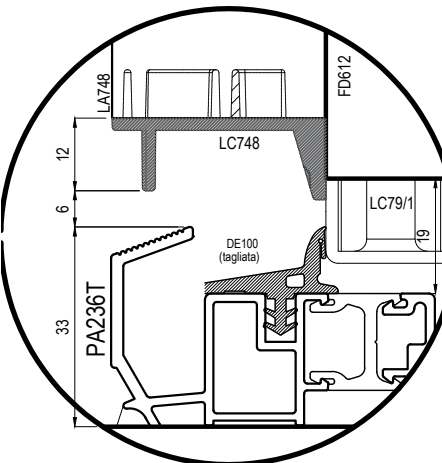
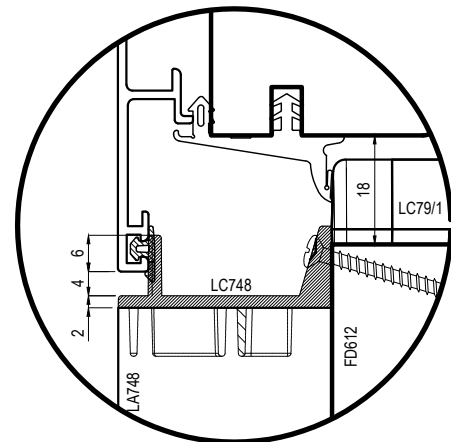

uni\_one - Sistema Complanare

Scala 0.8:1

Produced with:  
uni\_one  
TECHNOLOGY

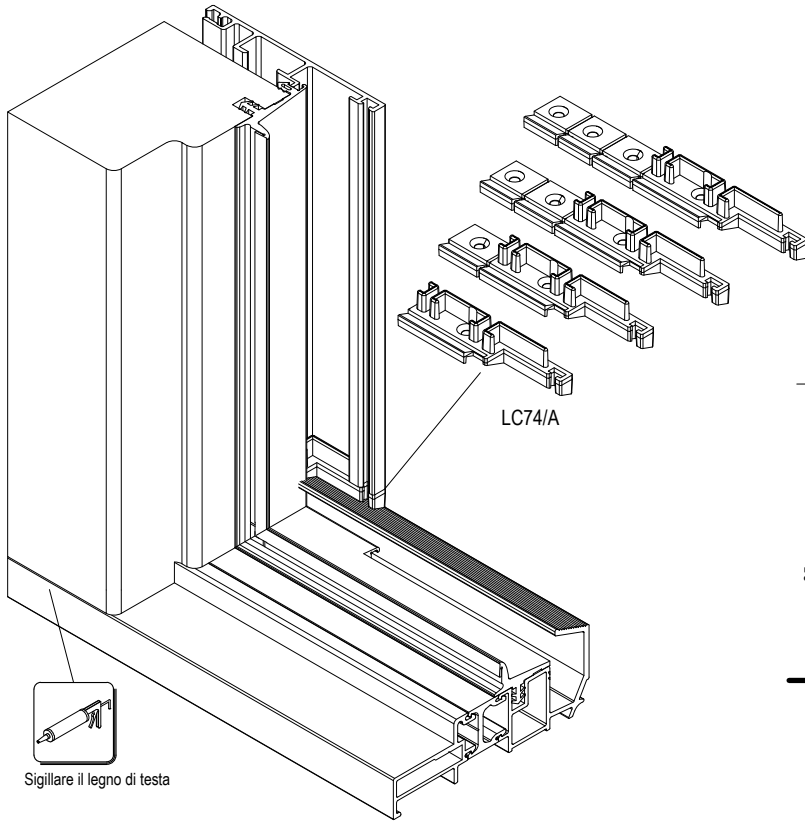

Alluminio	Accessorio
LA791	LC74/A tagliato
LA794	LC74/A tagliato
LA746	LC74/A tagliato
LA776	LC74/A

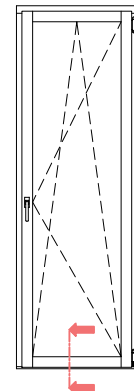
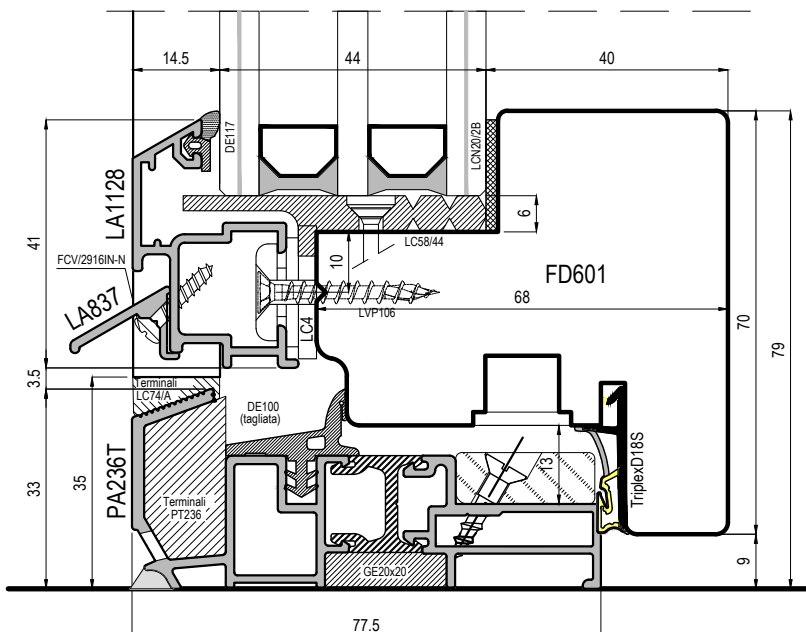
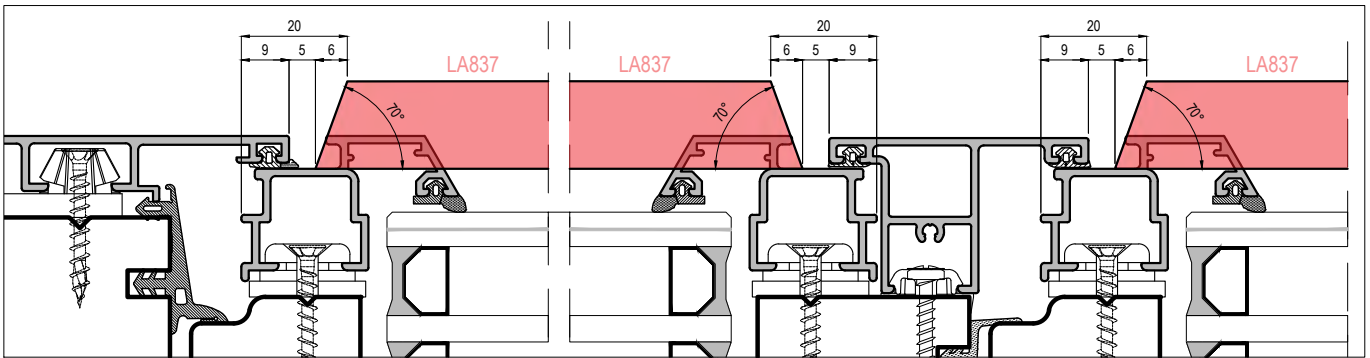
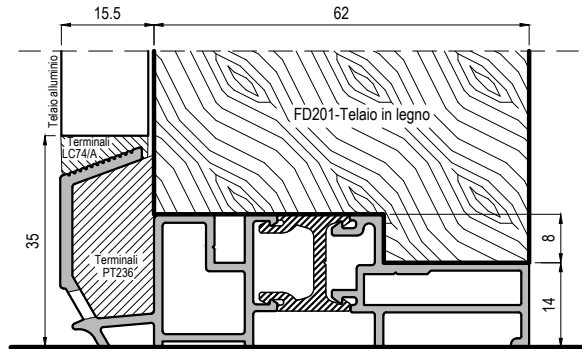

## uni\_one - Sistema Complanare

Scala 0.8:1

CT uni\_one Complanare-ver.00/02.24

Produced with:  
**uni\_one**  
 TECHNOLOGY



Conforme alla normativa per l'abbattimento delle barriere architettoniche BARRIER FREE

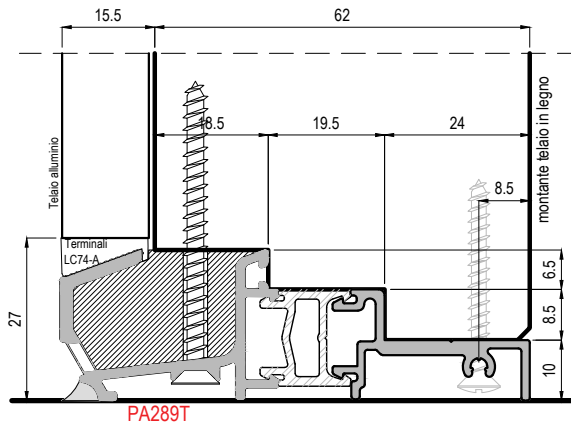
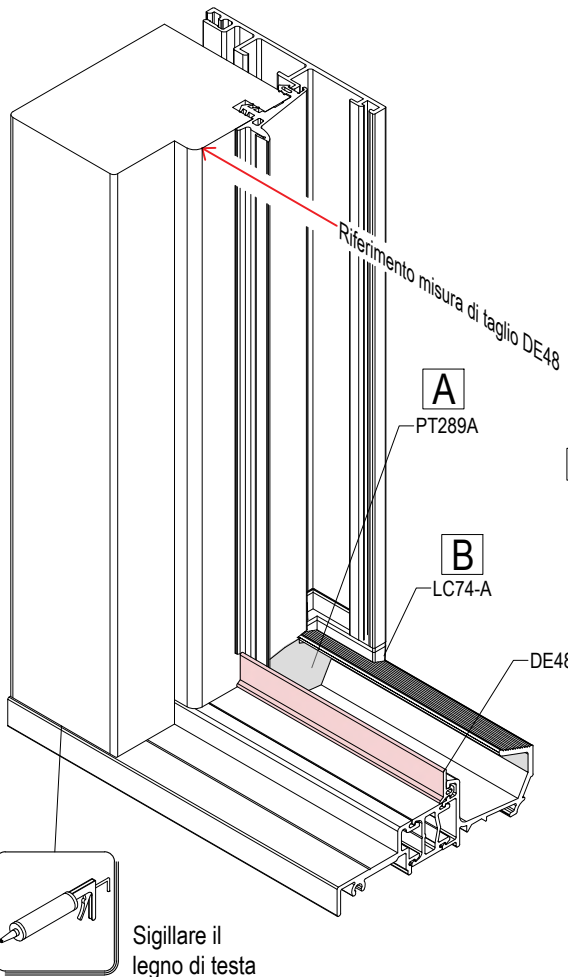

A			B	
Telaio	Accessorio	Misura	Alluminio	Accessorio
FD201-50	PT289A-50	50mm	LA780	LC74/A tagliato
FD201-70	PT289A-70	70mm	LA793	LC74/A tagliato
FD305	PT289A-38	38mm	LA783	LC74/A tagliato
FD312	PT289A-33	33mm	LA889	LC74/A
FD104	PT289A-70	70mm		

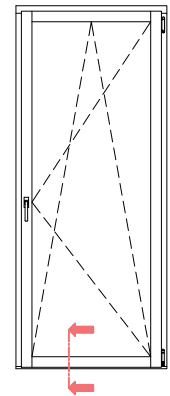
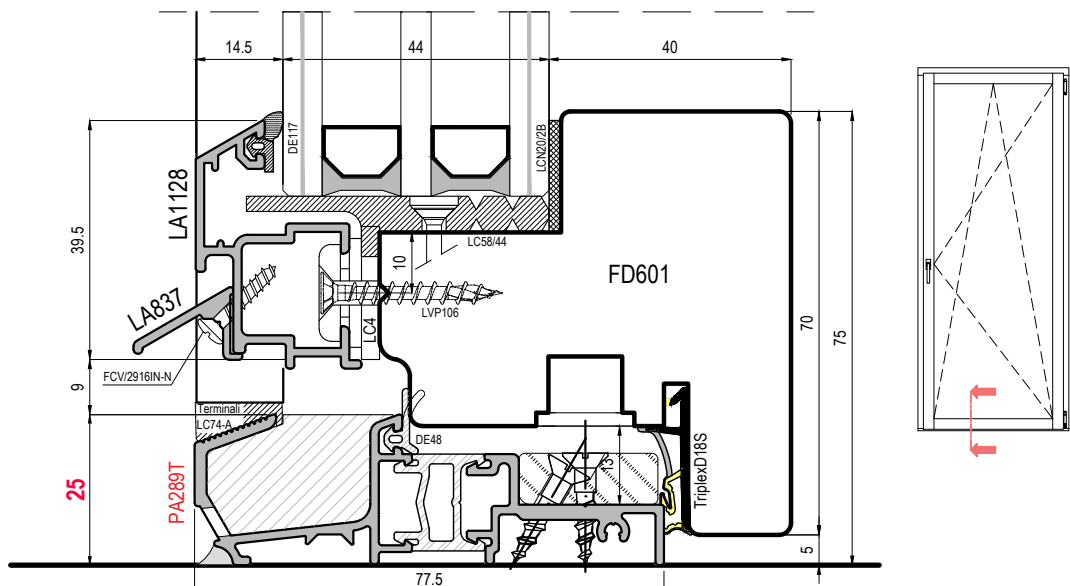
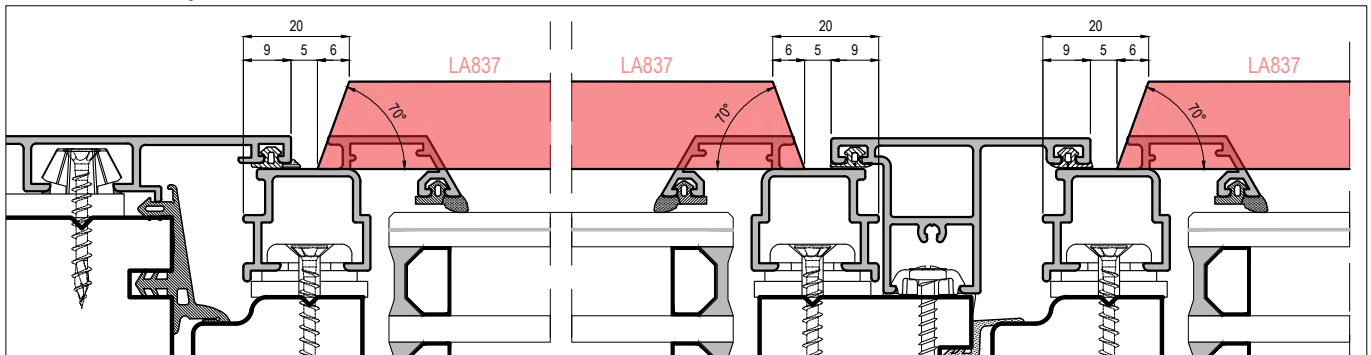

## uni\_one - Sistema Complanare

Scala 0.8:1

Produced with:  
uni\_one  
TECHNOLOGY



Conforme alla  
normativa per  
l'abbattimento  
delle barriere  
architettoniche  
**BARRIER FREE**

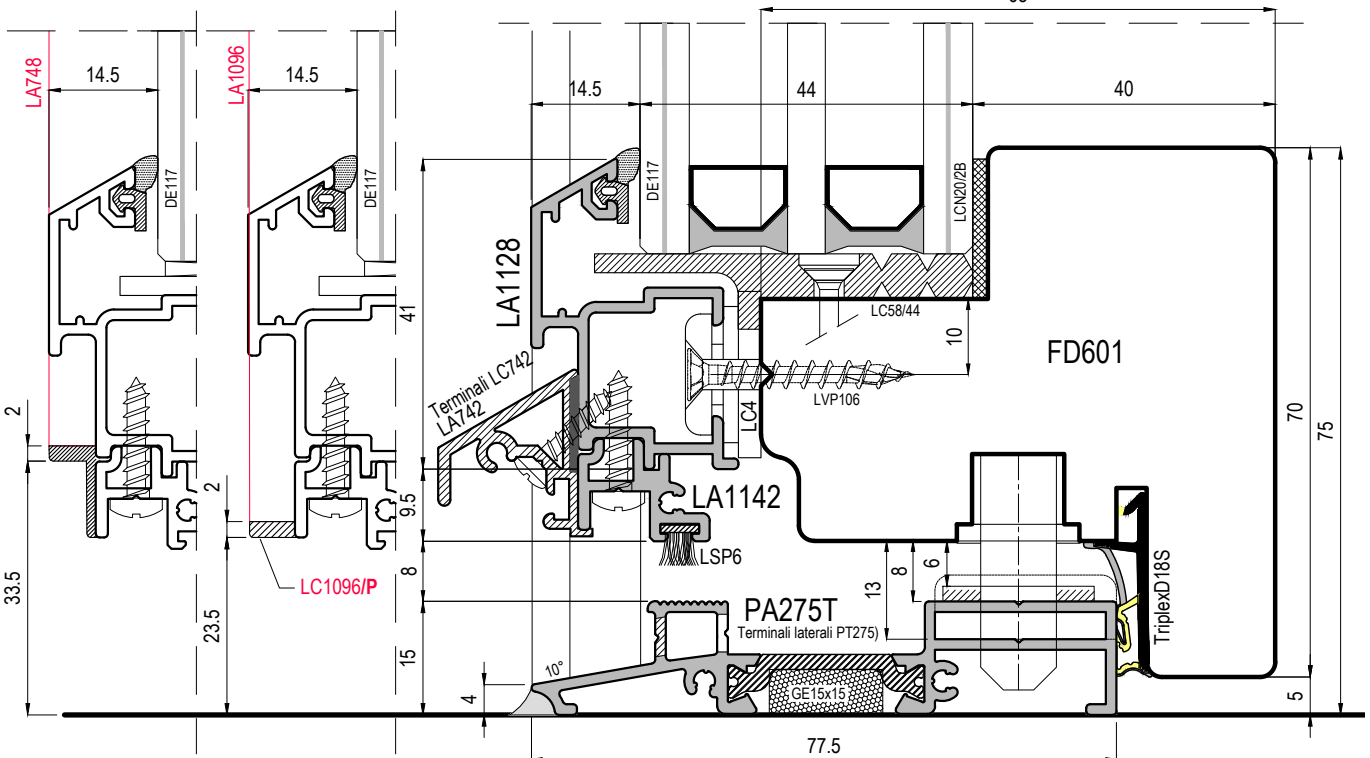
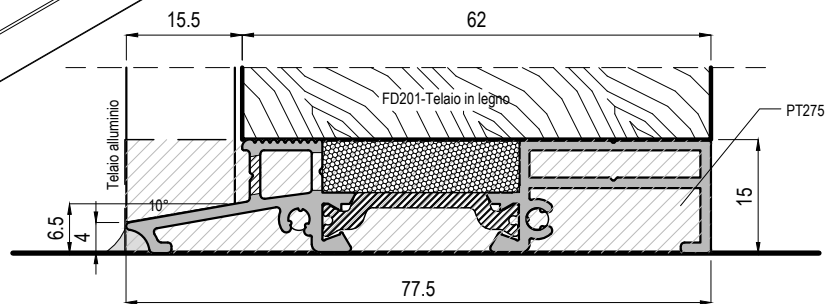
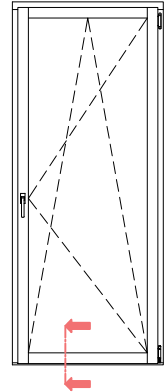
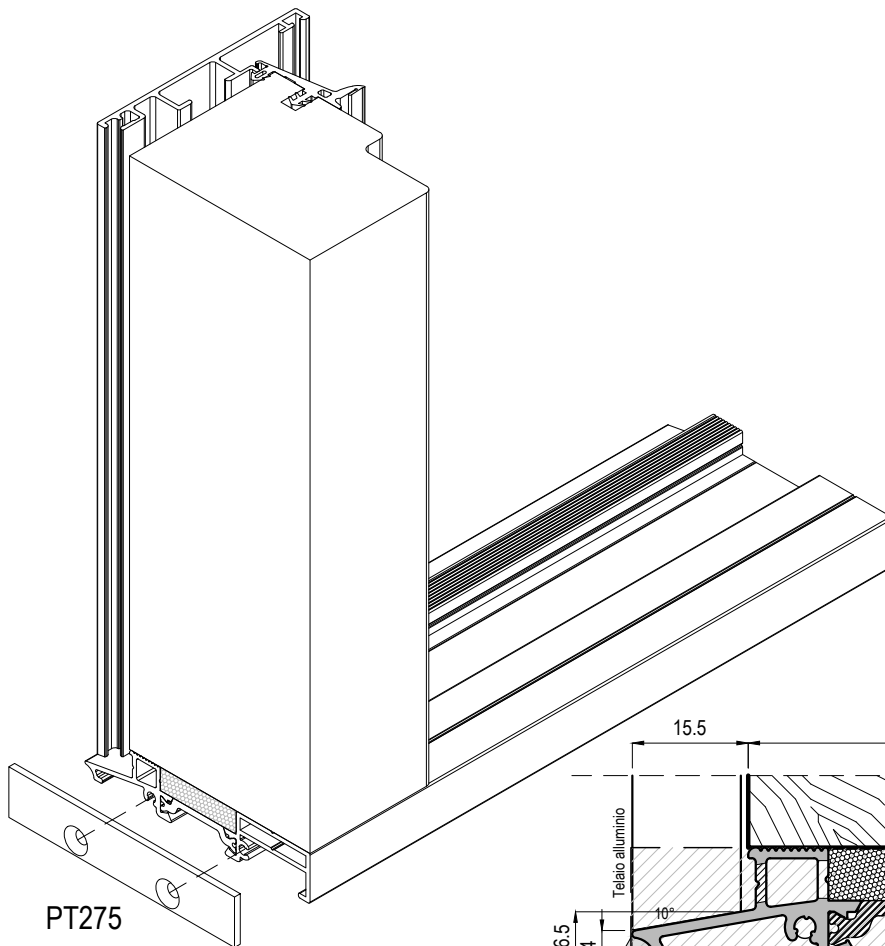

## uni\_one - Sistema Complanare

Scala 1:1

CT uni\_one Complanare-ver.00/02.24

Produced with:  
**uni\_one**  
TECHNOLOGY



Soluzione non coperta da Cascading

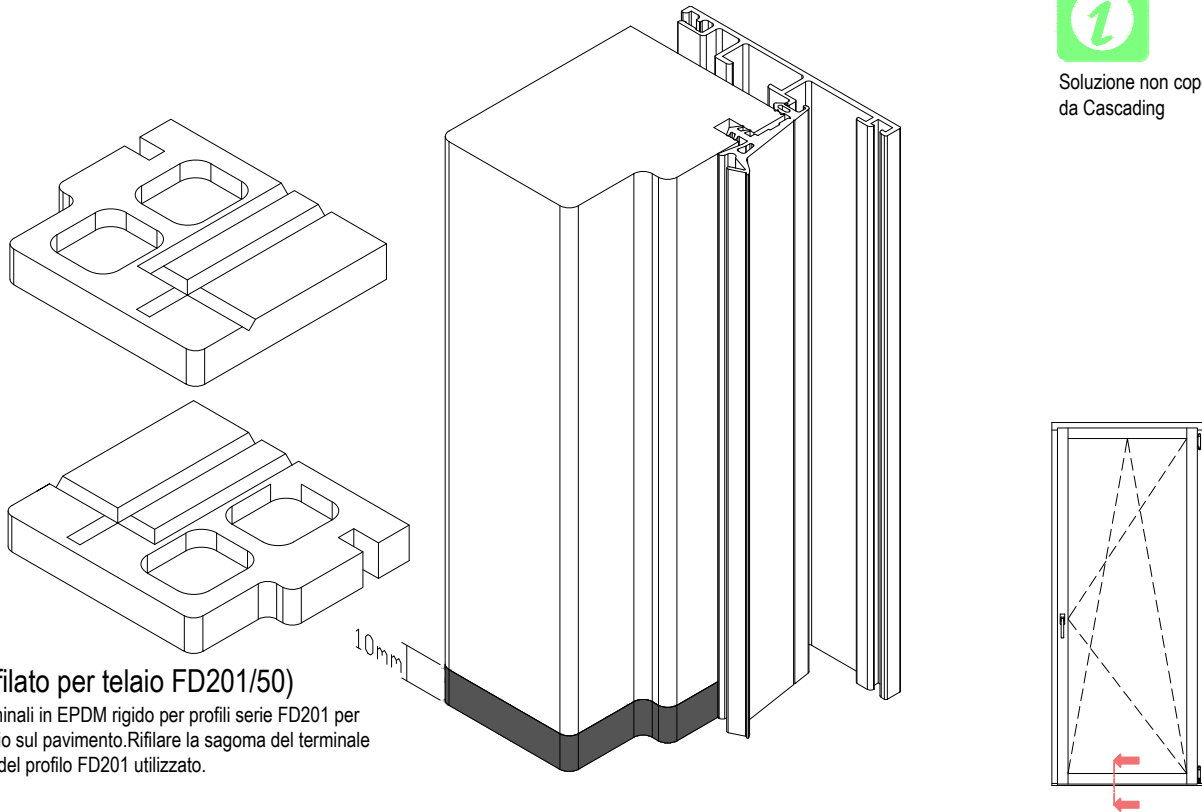

### LC85(rifilato per telaio FD201/50)

Coppia terminali in EPDM rigido per profili serie FD201 per la posa telaio sul pavimento. Rifilare la sagoma del terminale in funzione del profilo FD201 utilizzato.

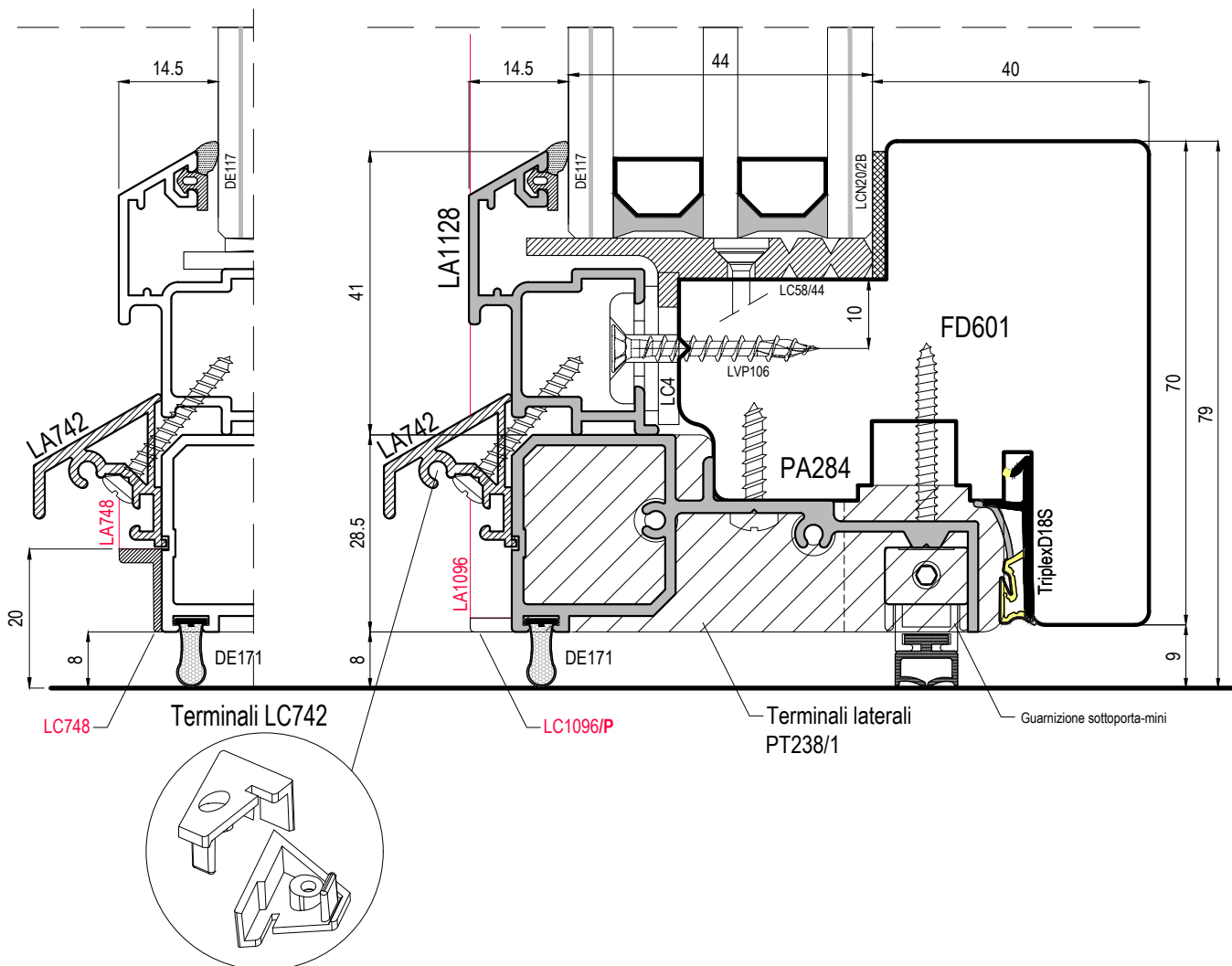

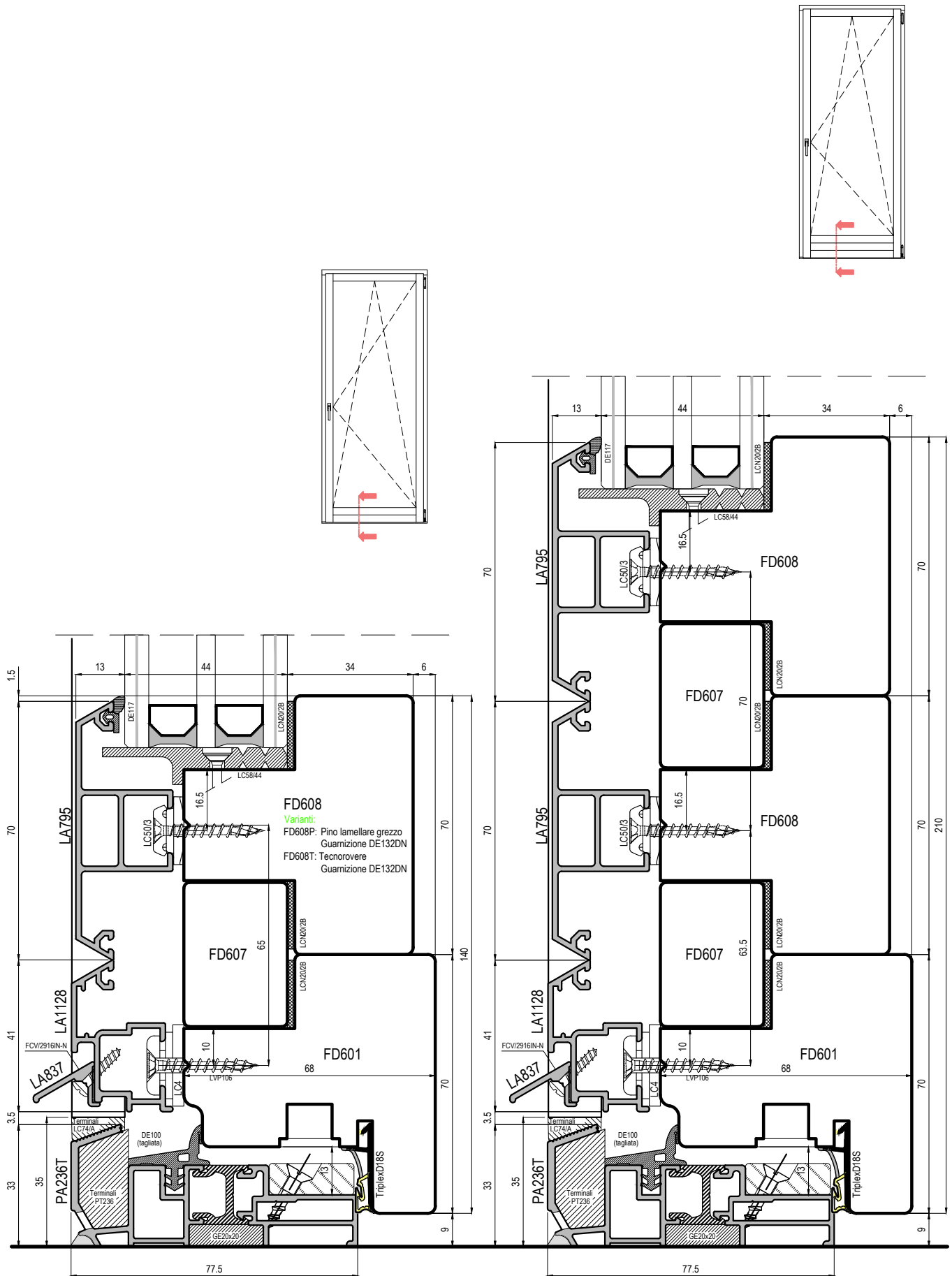

uni\_one - Sistema Complanare

Scala 0.7:1





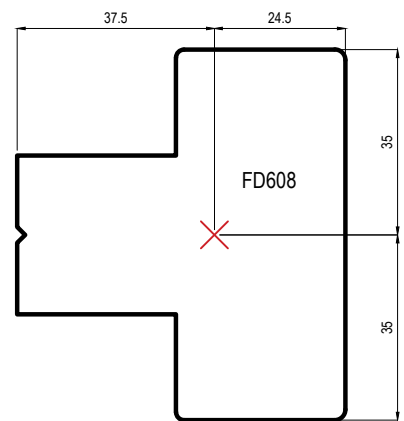
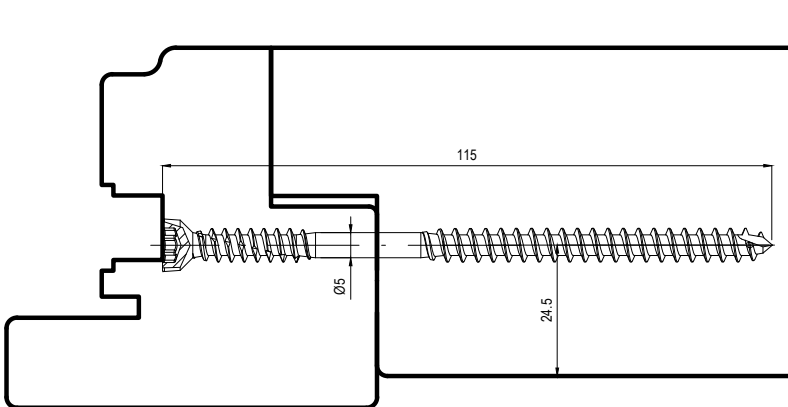
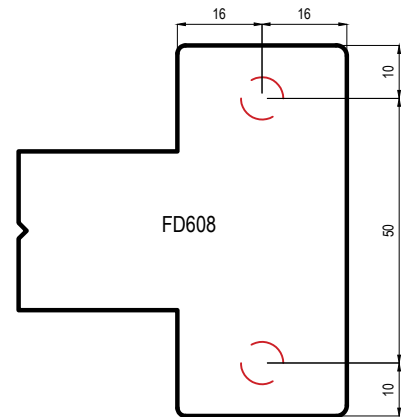
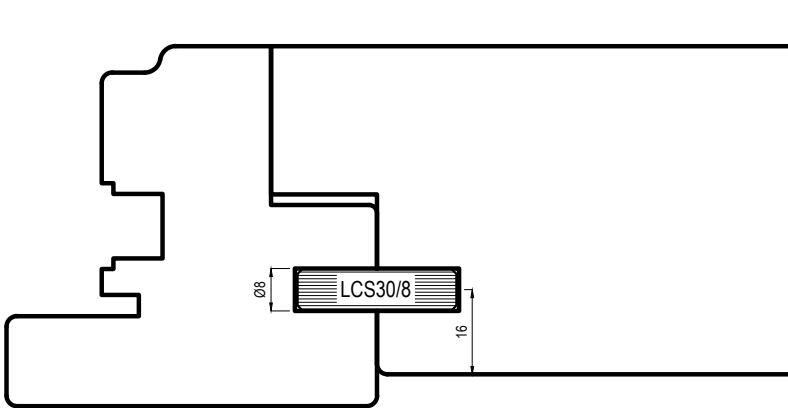
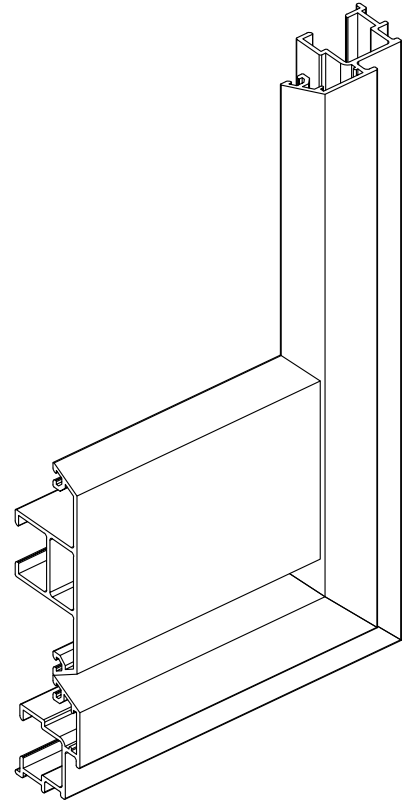
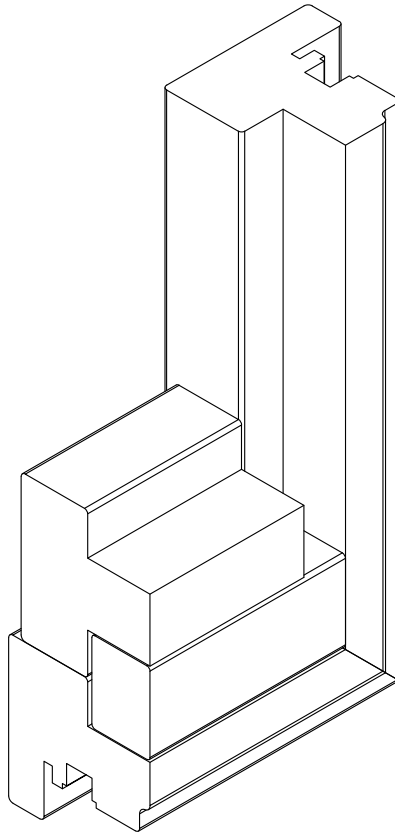
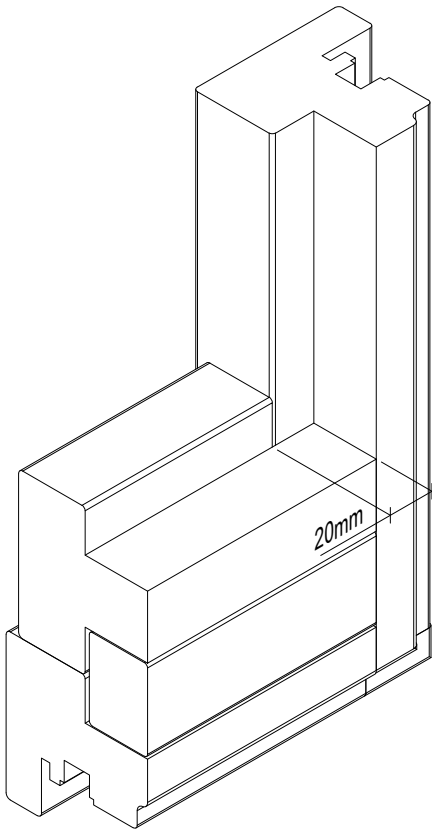

## uni\_one - Sistema Complanare

Scala 0.7:1

CT uni\_one Complanare-ver.00/02.24

Produced with:  
uni\_one  
TECHNOLOGY

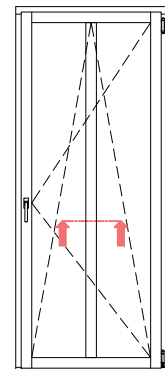
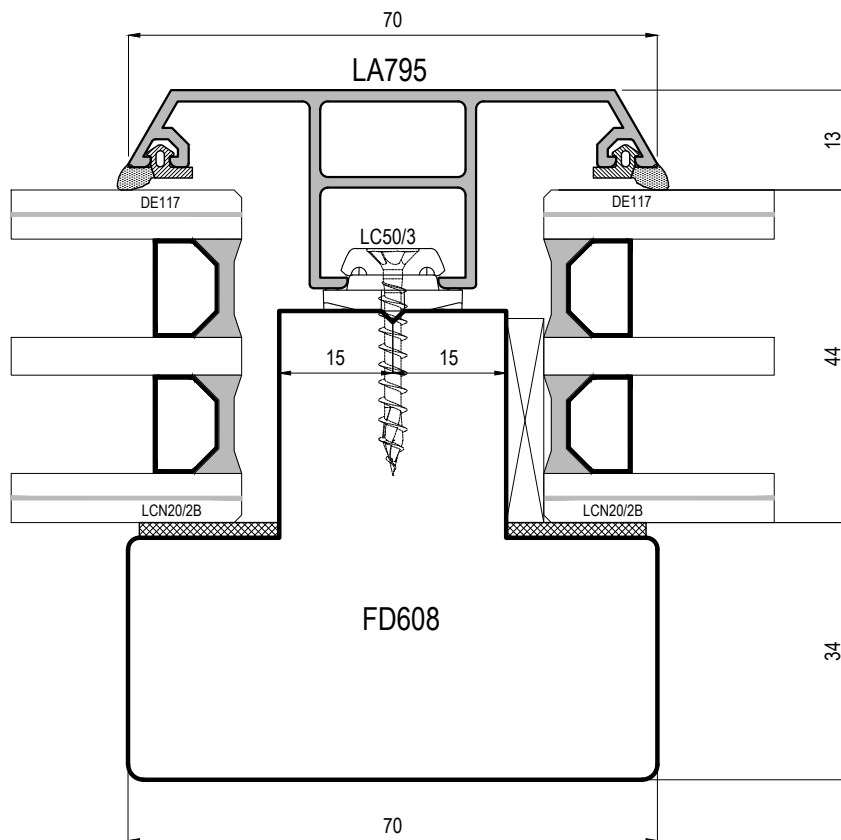
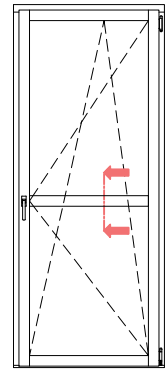
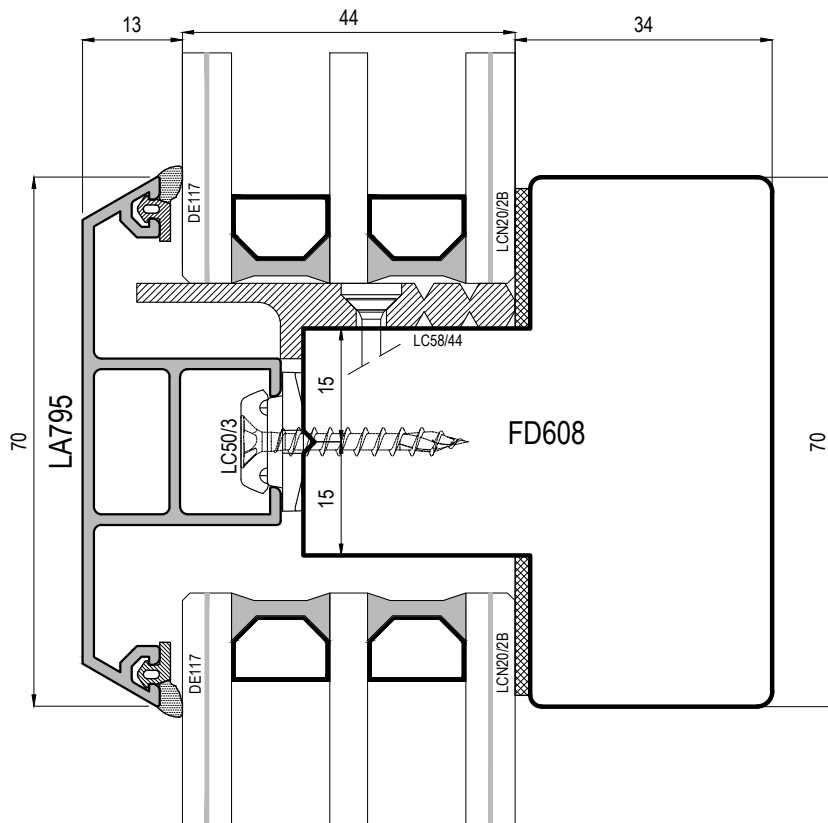

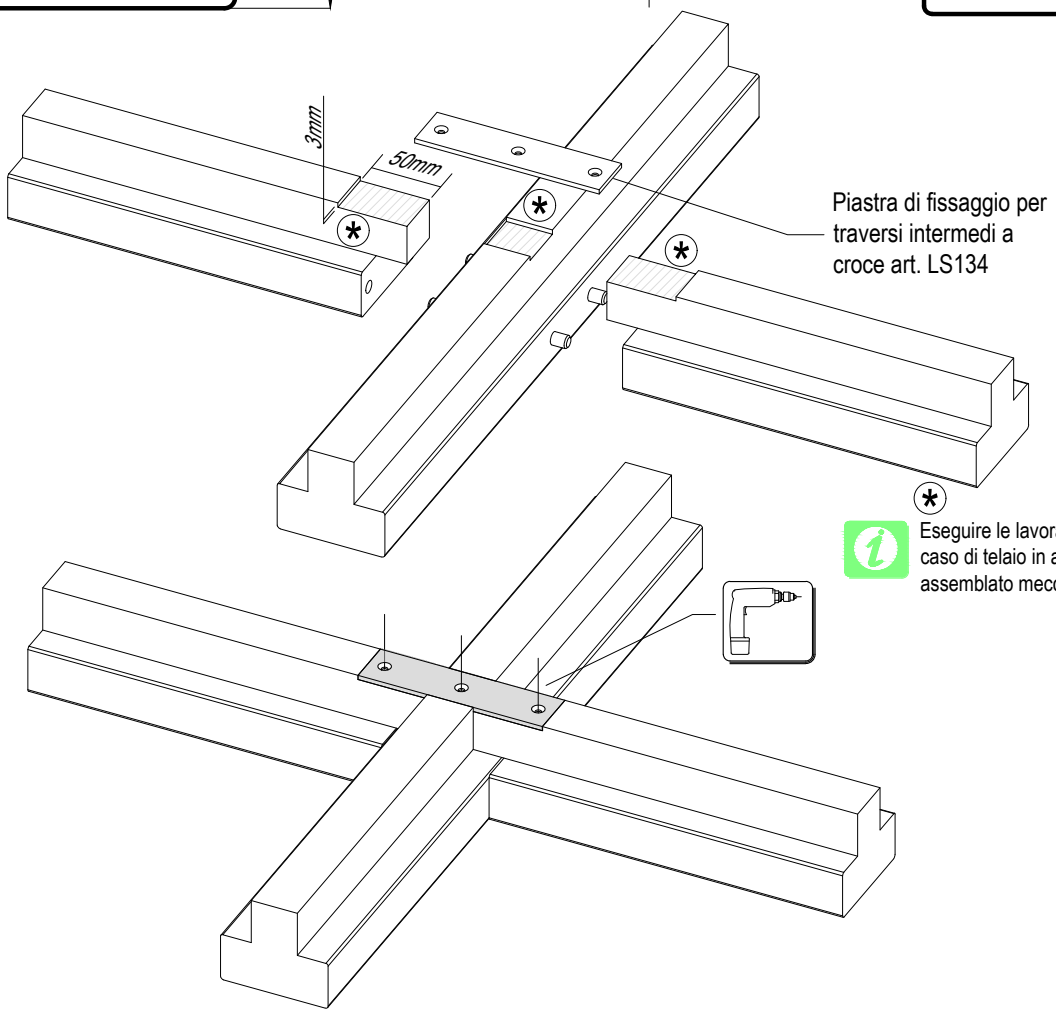
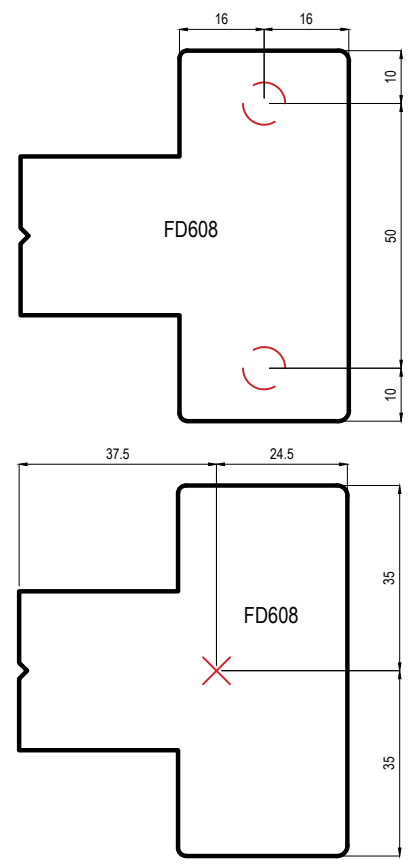
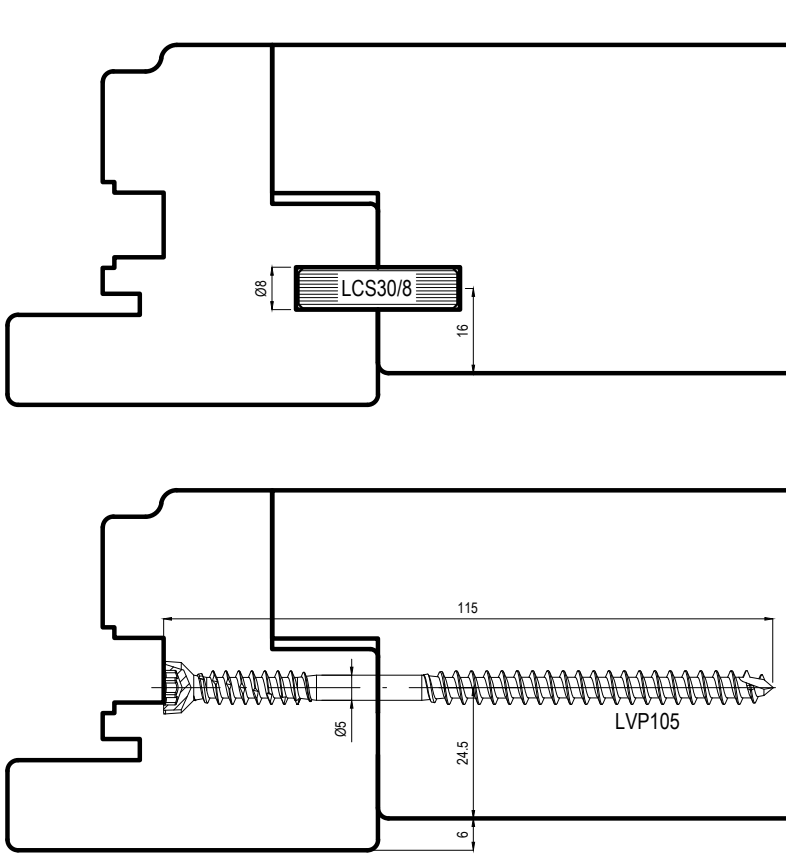

Piastra di fissaggio per traversi intermedi a croce art. LS134

 Eeguire le lavorazioni solo nel caso di telaio in alluminio assemblato meccanicamente

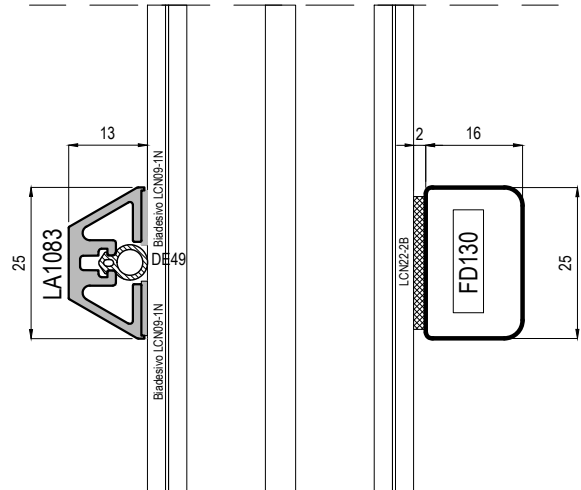
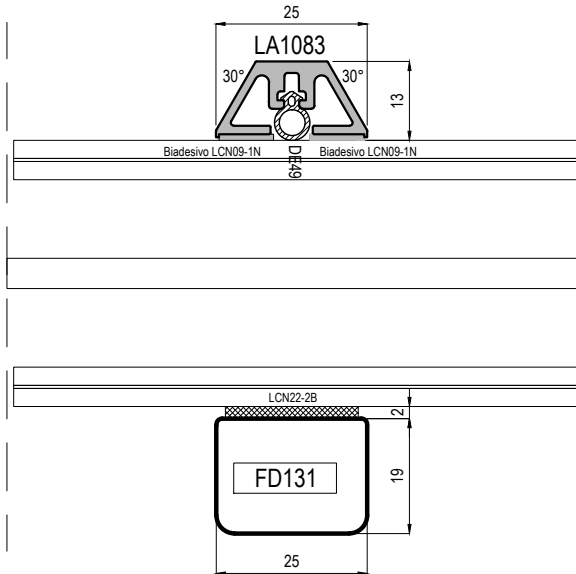
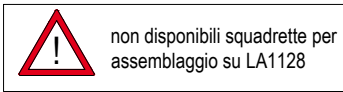
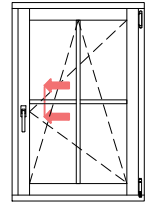
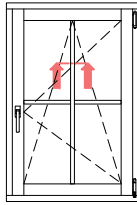

#### ISTRUZIONI PER IL MONTAGGIO DEI PROFILI INGLESINA:

1. Pulizia della superficie del vetro e dell'alluminio con alcool isopropilico LCALCOL-IP
2. Applicazione del LCPRIMER86 sui profili inglesina in alluminio
3. Attendere alcuni minuti per la completa asciugatura del prodotto ed applicare il nastro biadesivo sui profili
4. Rimuovere parte del biadesivo dalla parte centrale e applicare la colla LC-PUB600E(vedi schema 4.1)
5. Bagnare la superficie del vetro con alcol isopropilico: questa operazione permette al nastro biadesivo di incollarsi
6. Applicare i profili spressori o il telaio prima dell'evaporazione dell'alcol dalla superficie del vetro. Esercitare un'adeguata pressione per fare aderire correttamente il biadesivo al vetro
7. Tenere l'anta in posizione orizzontale con l'applicazione di un peso soprattutto negli incroci tra inglesine per favorire il corretto incollaggio
8. Attendere almeno 2 ore prima della rimozione dei pesi e l'installazione dell'anta

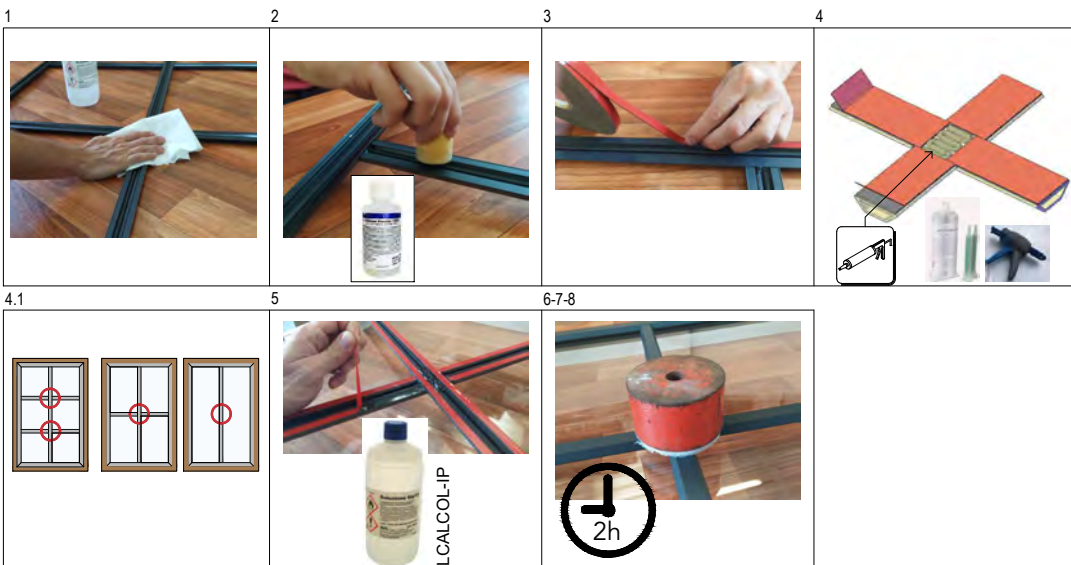

Per maggiori dettagli:  
<http://www.uniform.it/prodotti/systems/profili-traversi-intermedi-anta/>

uni\_one - Sistema Complanare

Scala 0.8:1

CT uni\_one Complanare-ver.00/02.24

Produced with:  
**uni\_one**  
 TECHNOLOGY

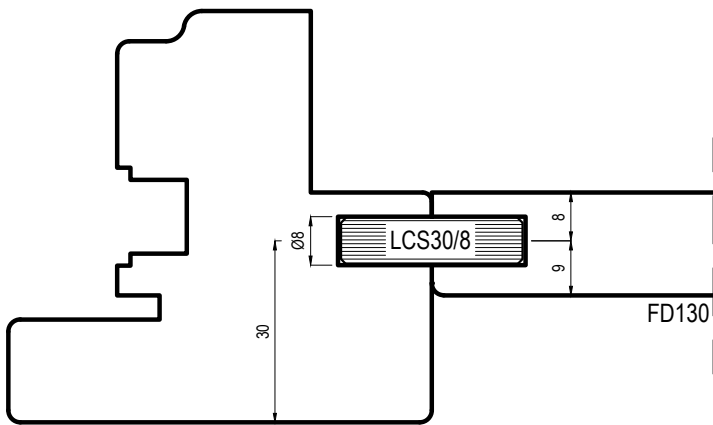

Assemblaggio con graffe metalliche (Lungh. max=15mm) tra i traversi FD130 e FD131

LCS30-8

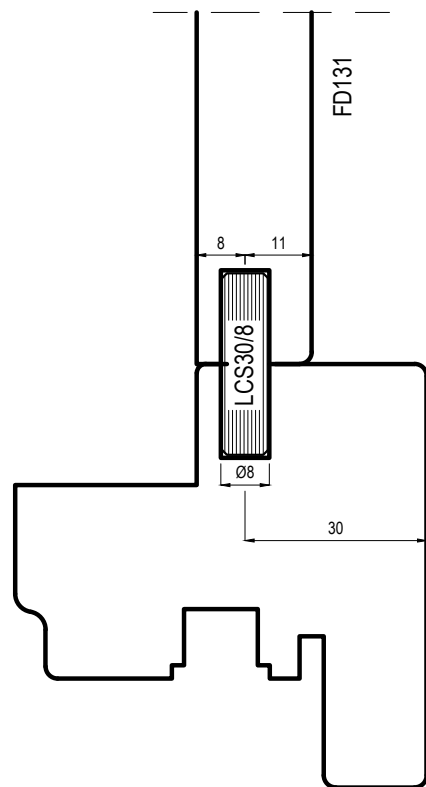
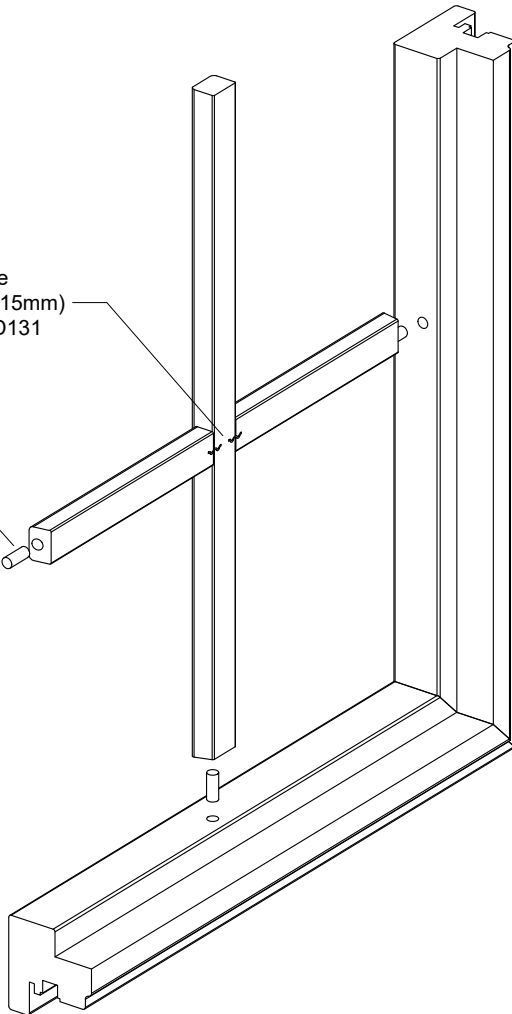

Istruzioni per il corretto incollaggio dei profili inglesina al vetro:

- 1) Nel caso il nastro biadesivo non fosse già premontato sul profilo in legno, è sufficiente pulire la parte in legno eliminando tracce di polveri o altri residui prima dell'applicazione
- 2) Pulizia della superficie del vetro con alcool isopropilico
- 3) Spruzzare leggermente il vetro con alcool isopropilico nella zona di contatto con il biadesivo. Ciò permette successivamente di evitare la formazione di bolle d'aria tra il nastro ed il vetro
- 4) Rimozione della pellicola protettiva del biadesivo e fissaggio al vetro. Applicare una pressione adeguata in modo da fare aderire tutta la superficie del nastro al vetro fino all'"asciugatura" e completa adesivizzazione dello stesso.

NOTE: la temperatura ideale per l'applicazione del nastro biadesivo è da 20 a 38° C. L'applicazione al di sotto dei 10° C è sconsigliata poiché l'adesivo risulta troppo rigido per aderire in modo appropriato.

Per maggiori dettagli:

<http://www.uniform.it/prodotti/systems/profilo-traversi-intermedi-anta/>

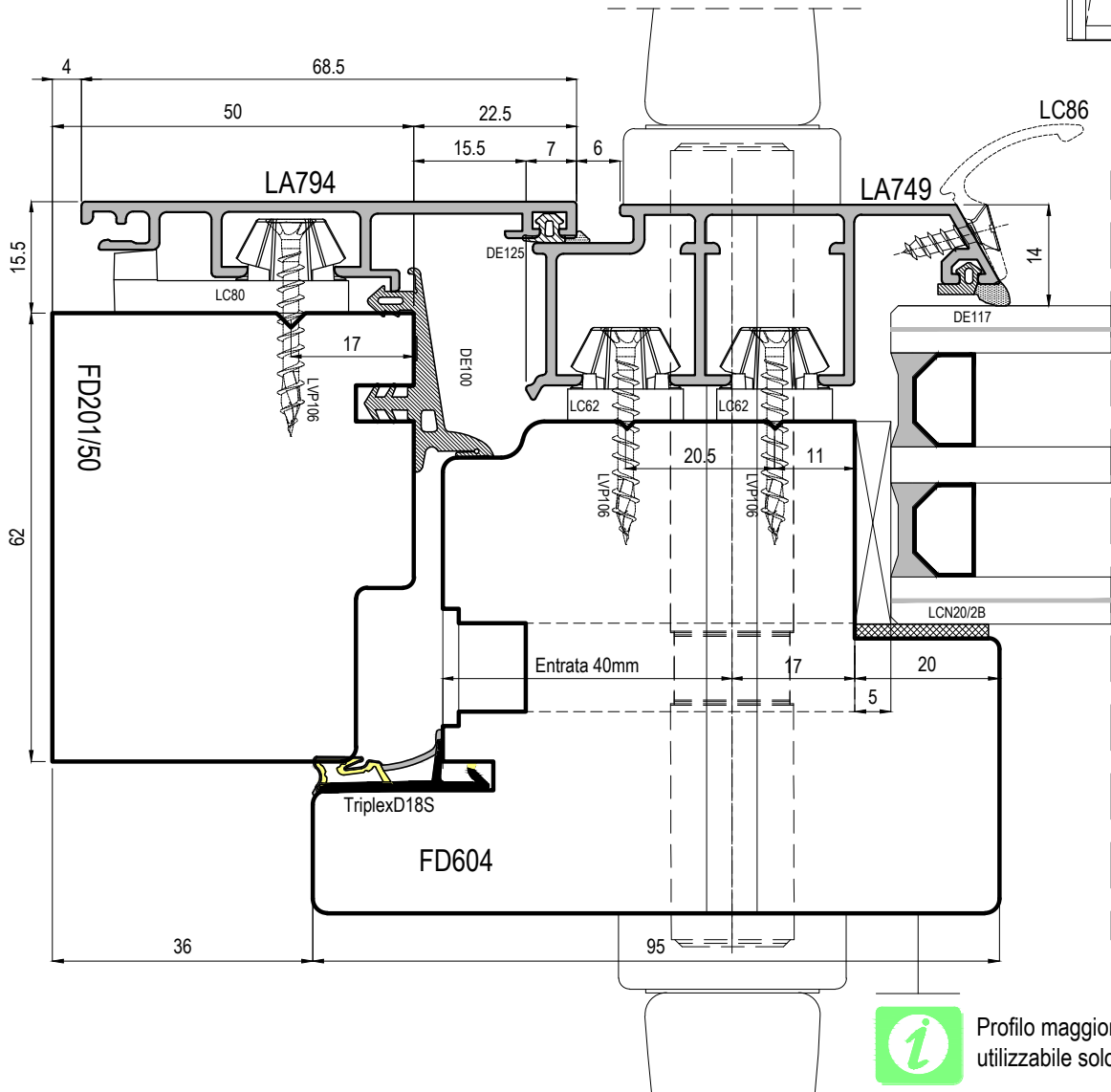
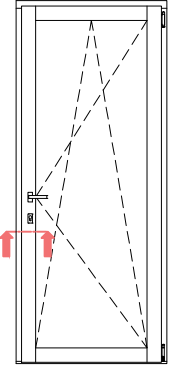

**i** Profilo maggiorato utilizzabile solo sui 4 lati

VARIANTE:  
Maniglia fissa  
esterna LC86

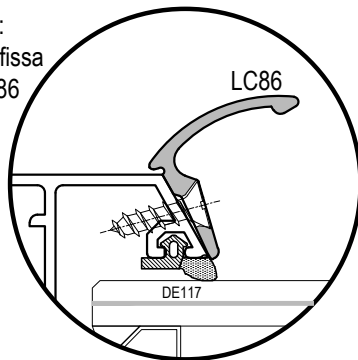



*Su richiesta  
On request*

Maniglia fissa esterna **LC86**  
Finiture disponibili:  
Bronzo chiaro, Testa di  
Moro, Argento, Bianco 9016

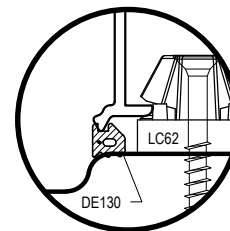
OPZIONALE:  
DE130 su anta

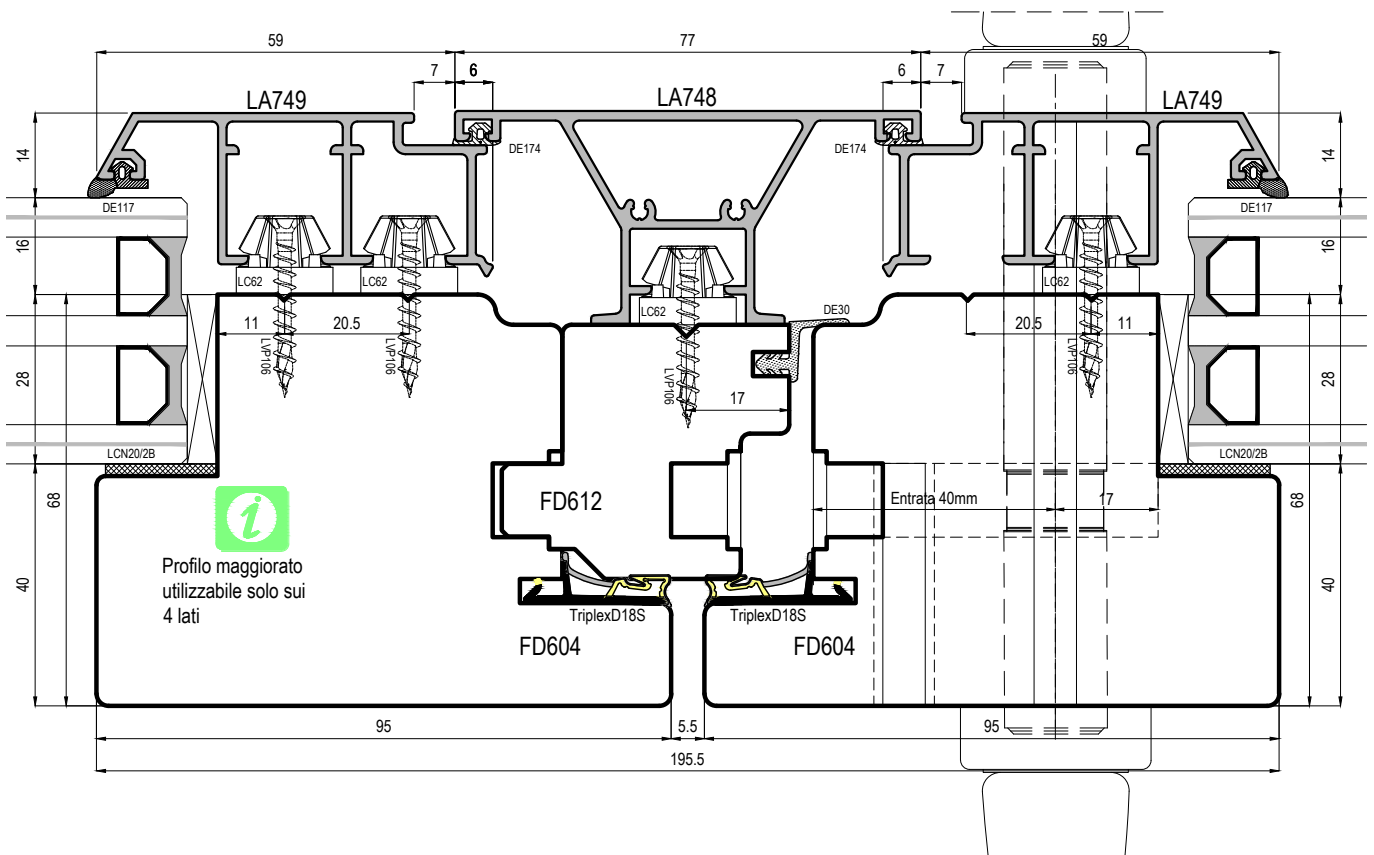
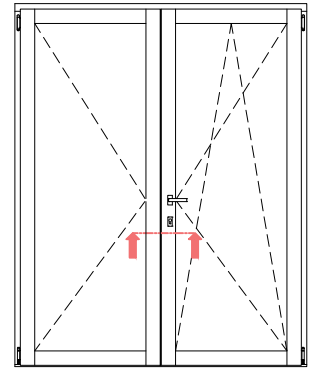



 Profilo maggiorato utilizzabile solo sui 4 lati

## uni\_one - Sistema Complanare

Scala 0.8:1

CT uni\_one Complanare-ver.00/02.24

Produced with:  

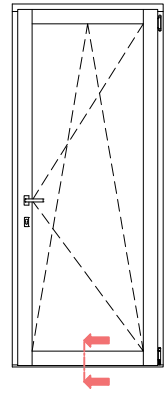
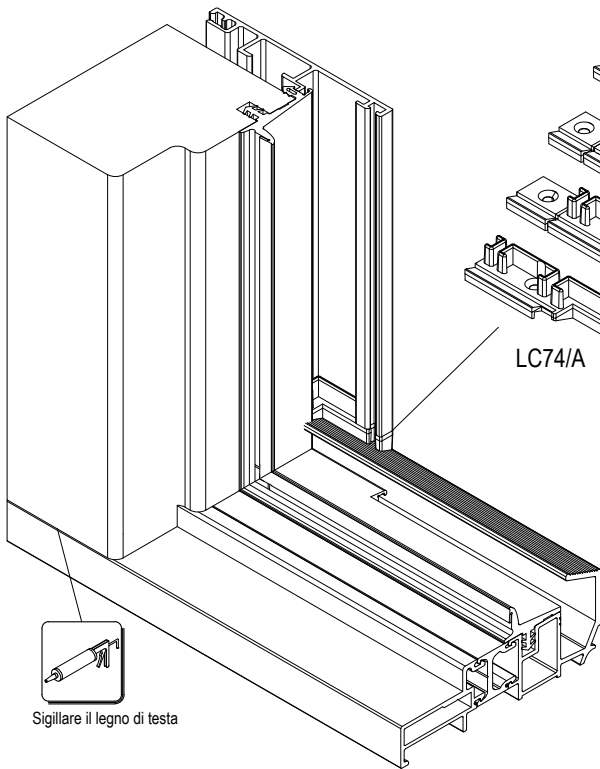
Alluminio	Accessorio
LA791	LC74/A tagliato
LA794	LC74/A tagliato
LA746	LC74/A tagliato
LA776	LC74/A

Sigillare il legno di testa

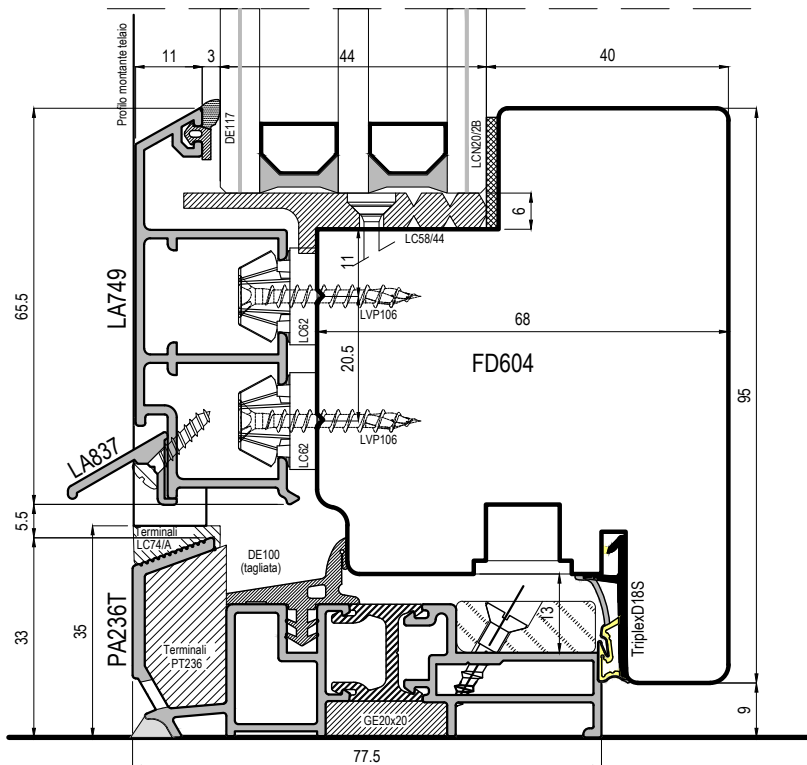
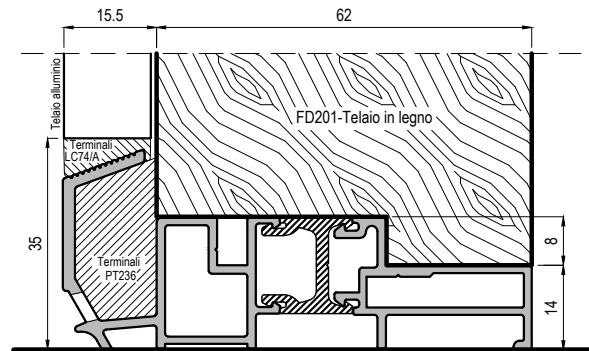

## uni\_one - Sistema Complanare

Scala 0.8:1

CT uni\_one Complanare-ver.00/02.24

Produced with:  
**uni\_one**  
 TECHNOLOGY





Conforme alla normativa per l'abbattimento delle barriere architettoniche BARRIER FREE

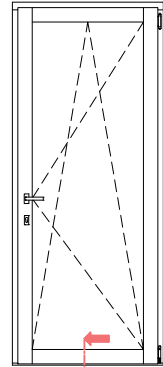
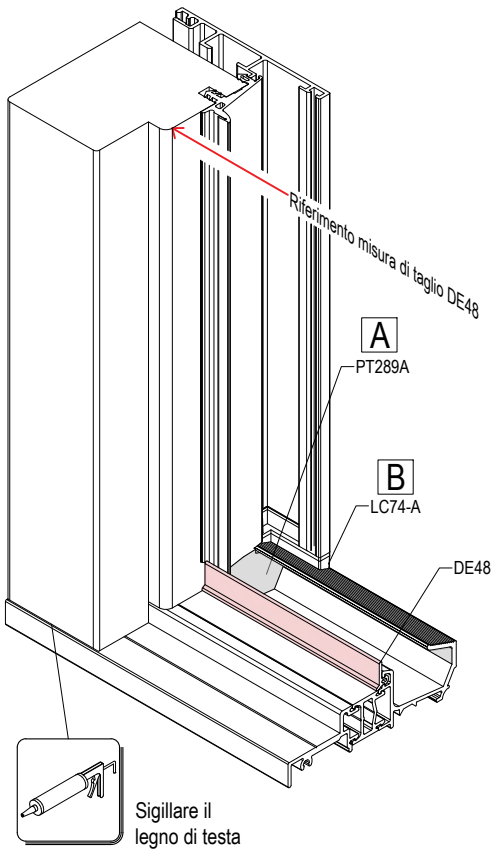

A	Telaio	Accessorio	Misura	B	Alluminio	Accessorio
	FD201-50	PT289A-50	50mm		LA780	LC74/A tagliato
	FD201-70	PT289A-70	70mm		LA793	LC74/A tagliato
	FD305	PT289A-38	38mm		LA783	LC74/A tagliato
	FD312	PT289A-33	33mm		LA889	LC74/A
	FD104	PT289A-70	70mm			

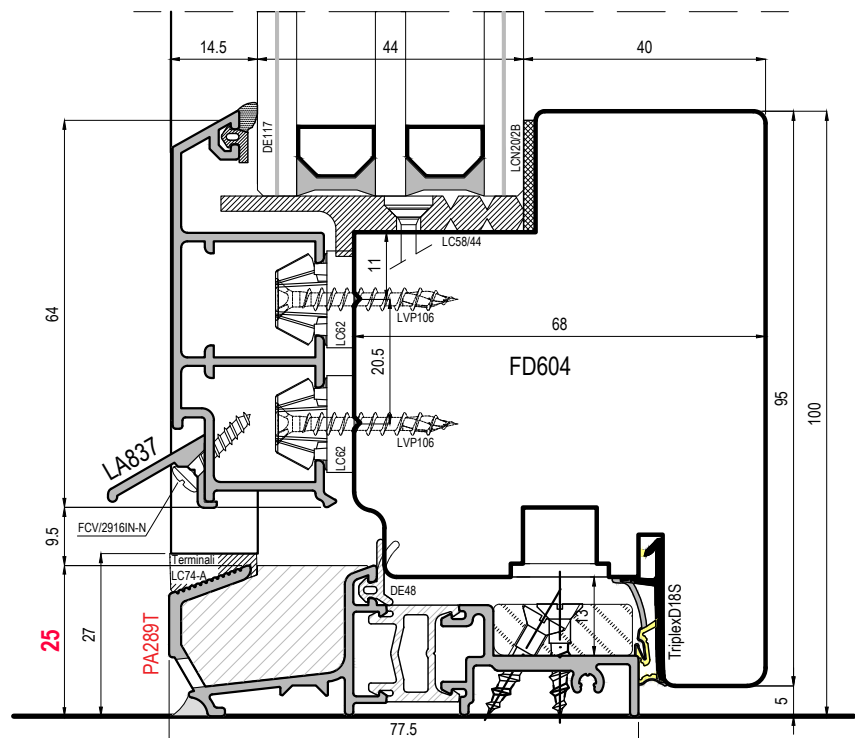
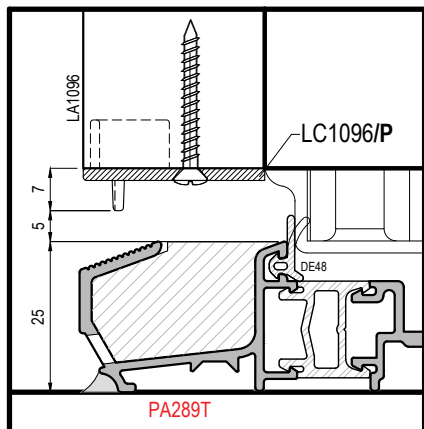
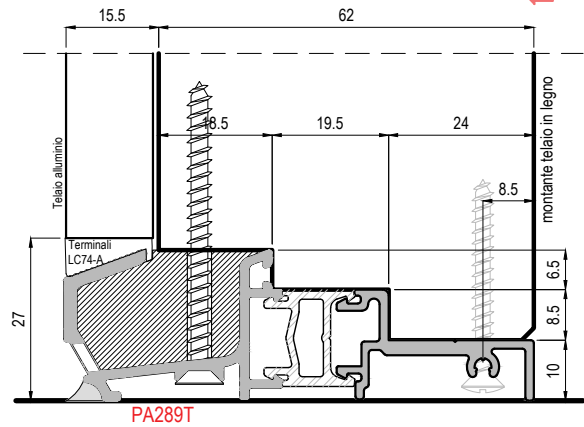

uni\_one - Sistema Complanare

Scala 0.8:1

CT uni\_one Complanare-ver.00/02.24

Produced with:  
uni\_one  
TECHNOLOGY



Conforme alla normativa per l'abbattimento delle barriere architettoniche BARRIER FREE

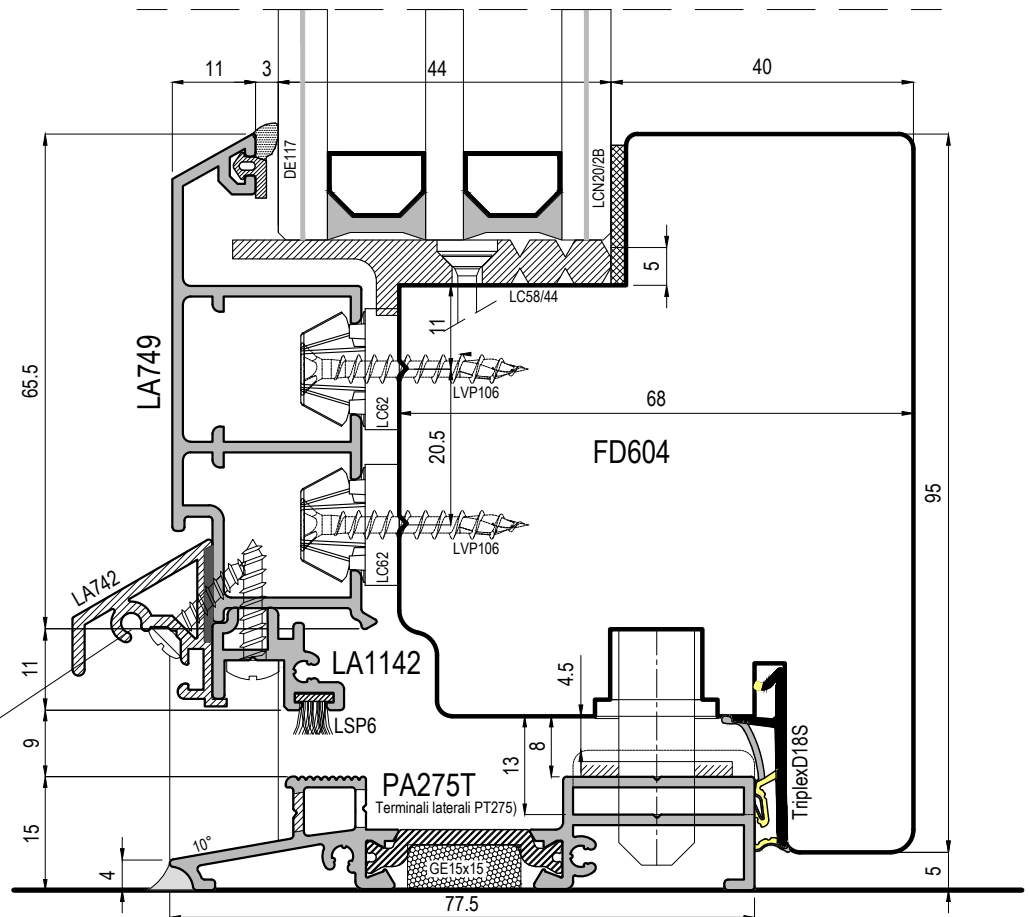
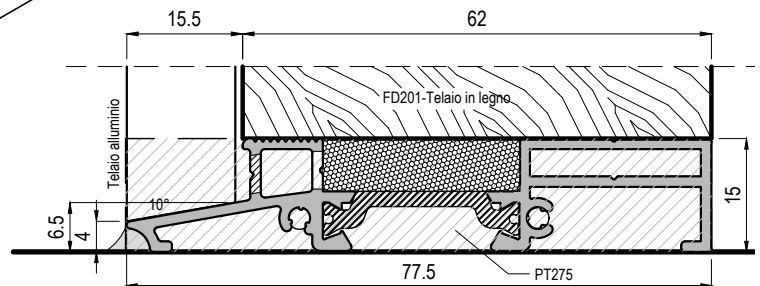
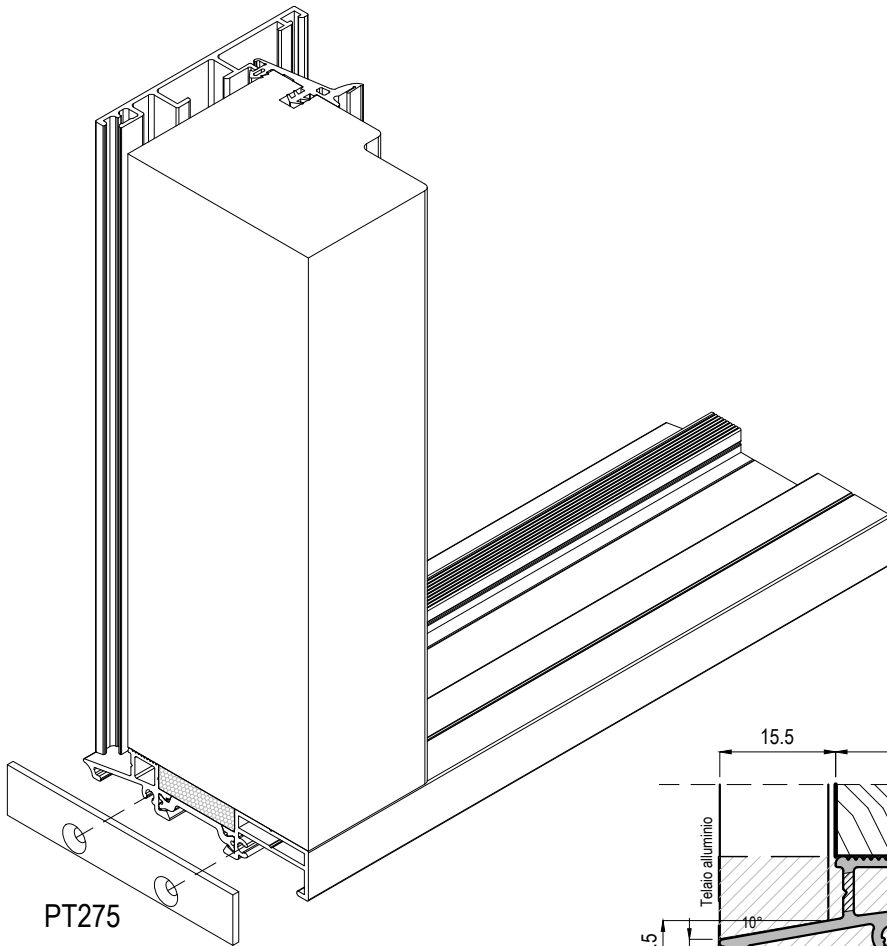
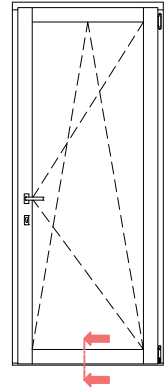

Terminali LC742

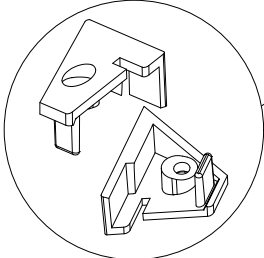

## uni\_one - Sistema Complanare

Scala 1:1

CT uni\_one Complanare-ver.00/02.24

Produced with:  
**uni\_one**  
TECHNOLOGY



Soluzione non coperta da Cascading

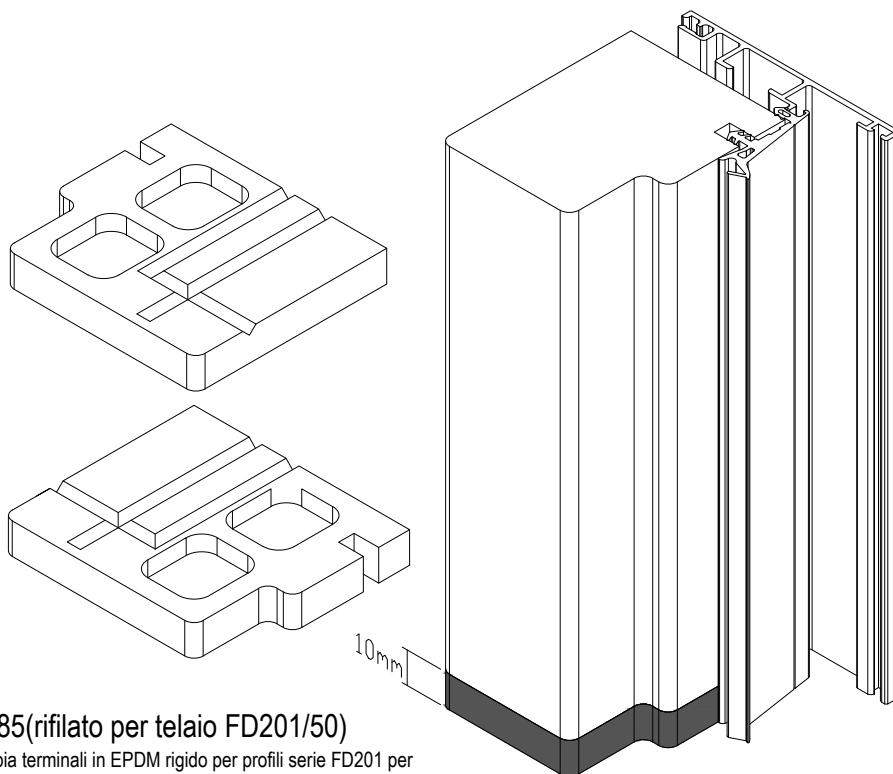

### LC85(rifilato per telaio FD201/50)

Coppia terminali in EPDM rigido per profili serie FD201 per la posa telaio sul pavimento. Rifilare la sagoma del terminale in funzione del profilo FD201 utilizzato.

### uni\_one 90°

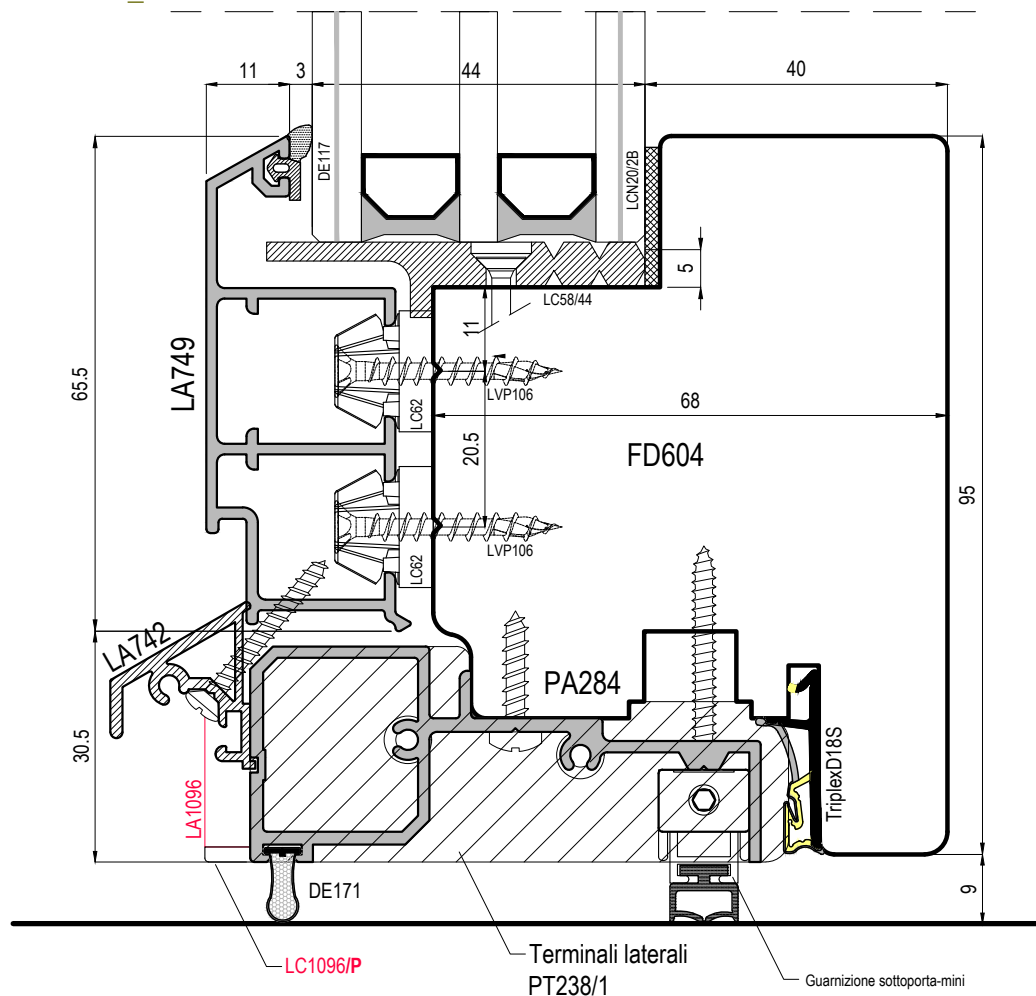

## uni\_one - Sistema Complanare

Scala 1:1

CT uni\_one Complanare-ver.00/02.24

Produced with:  
**uni\_one**  
TECHNOLOGY

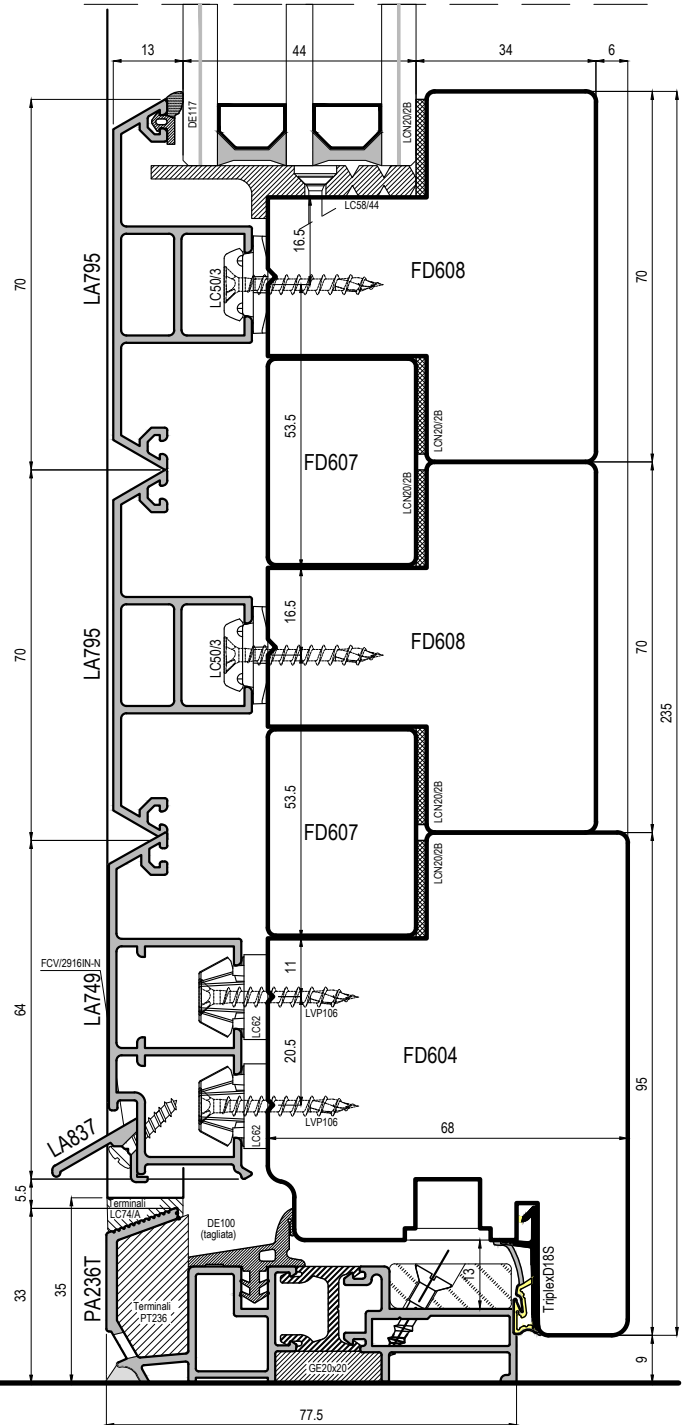
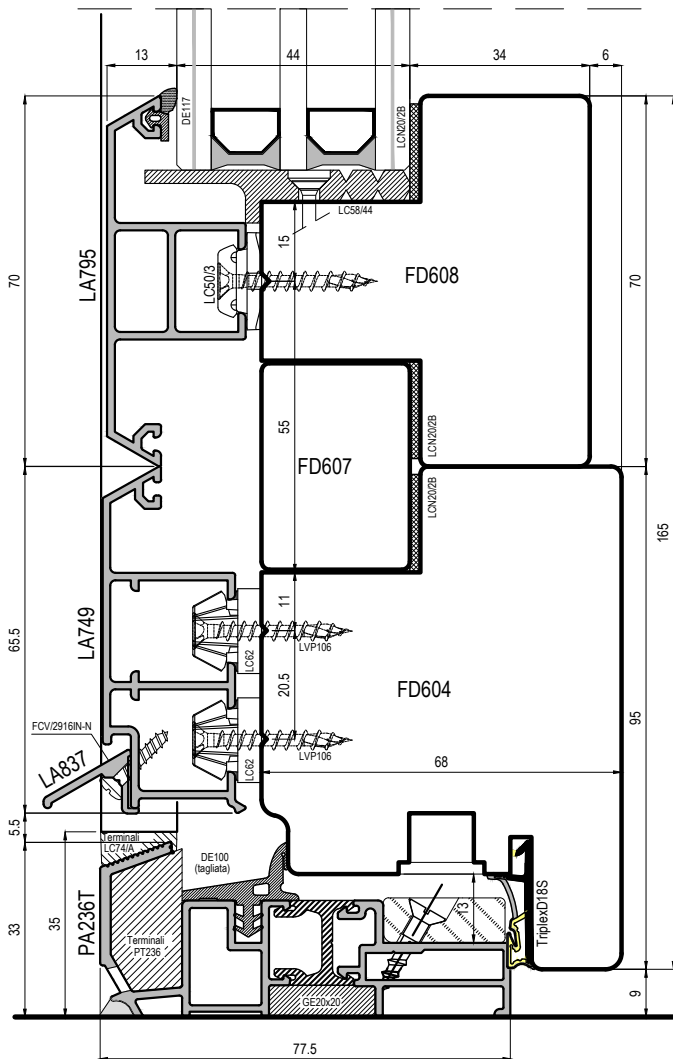
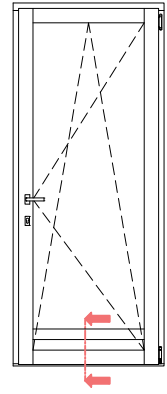
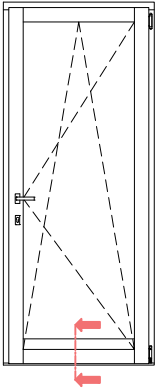

uni\_one - Sistema Complanare

Scala 0.7:1

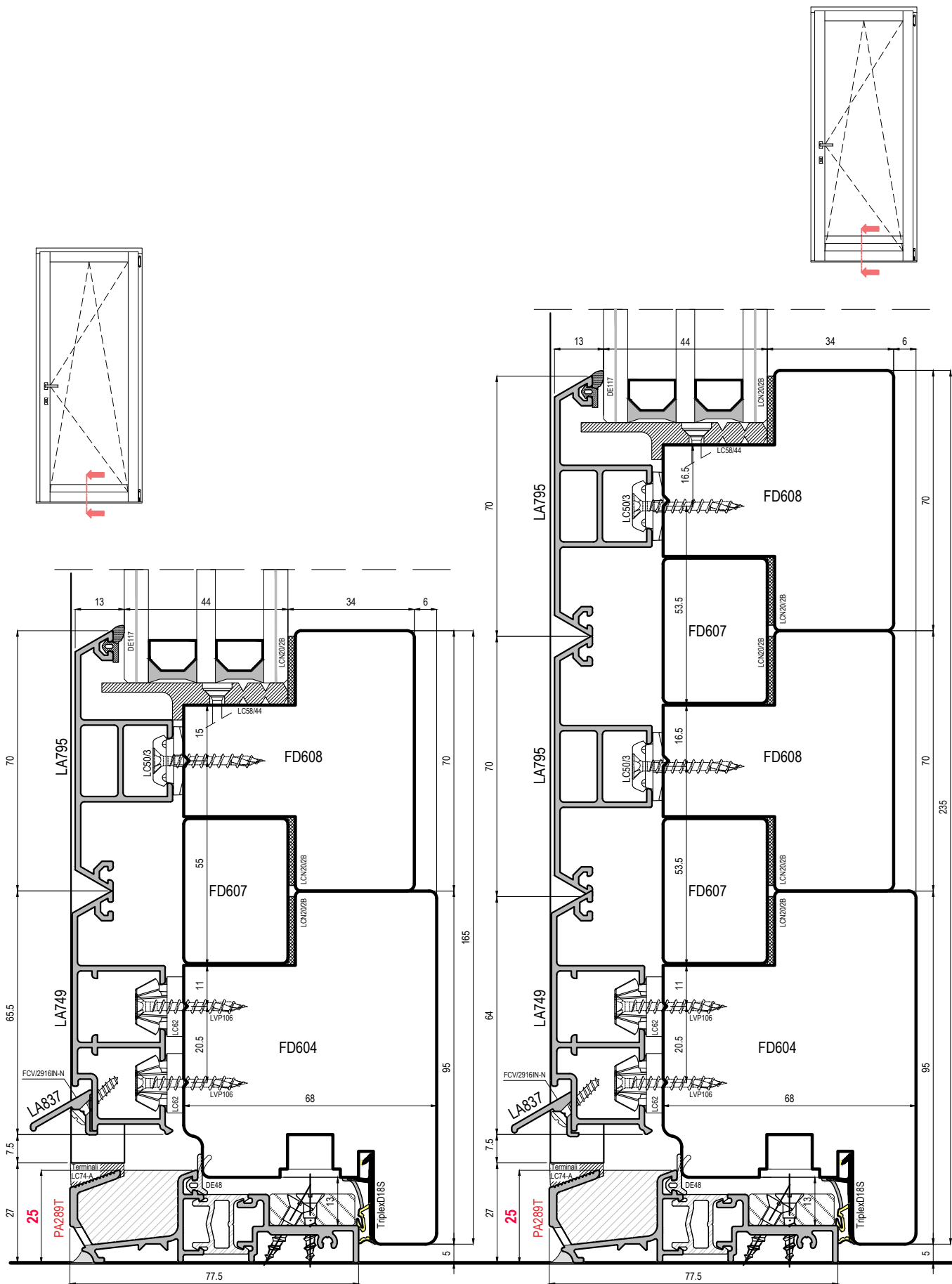

uni\_one - Sistema Complanare

Scala 0.7:1

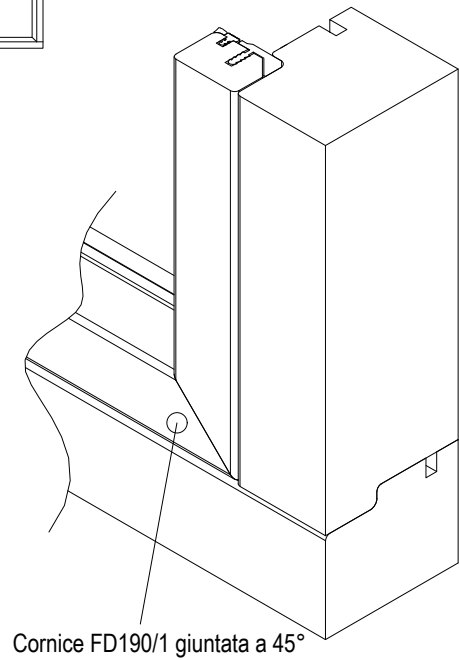
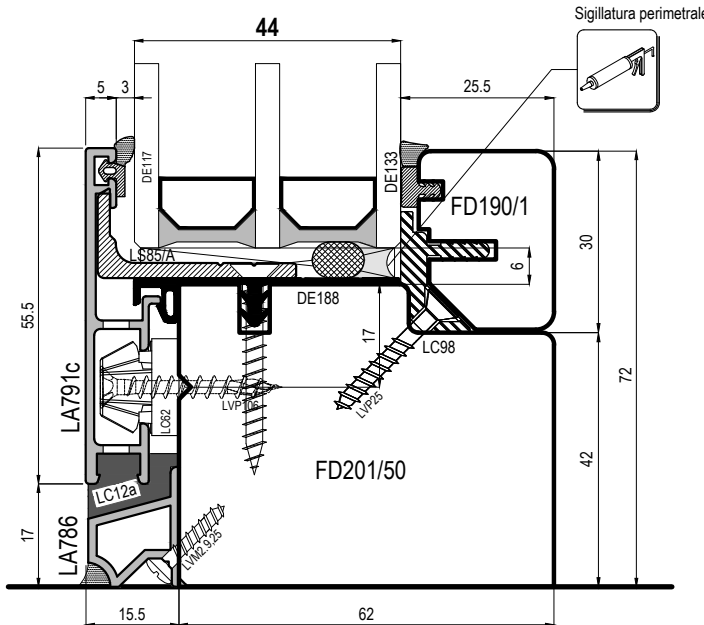
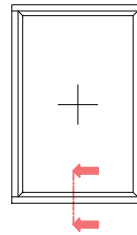
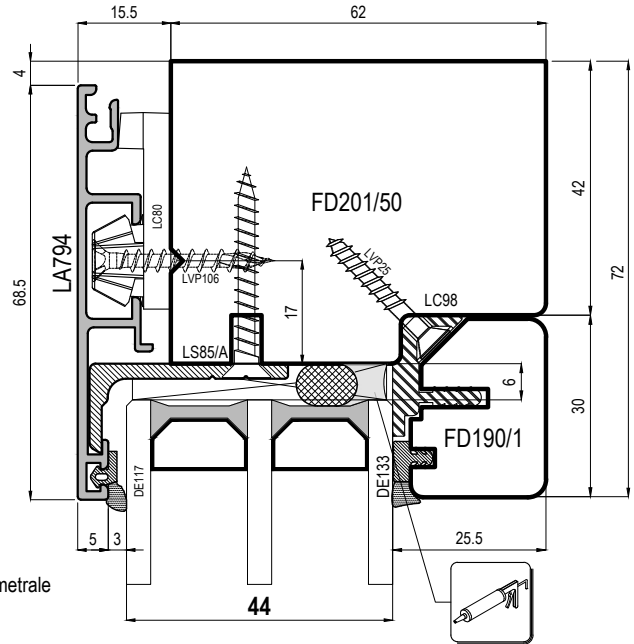
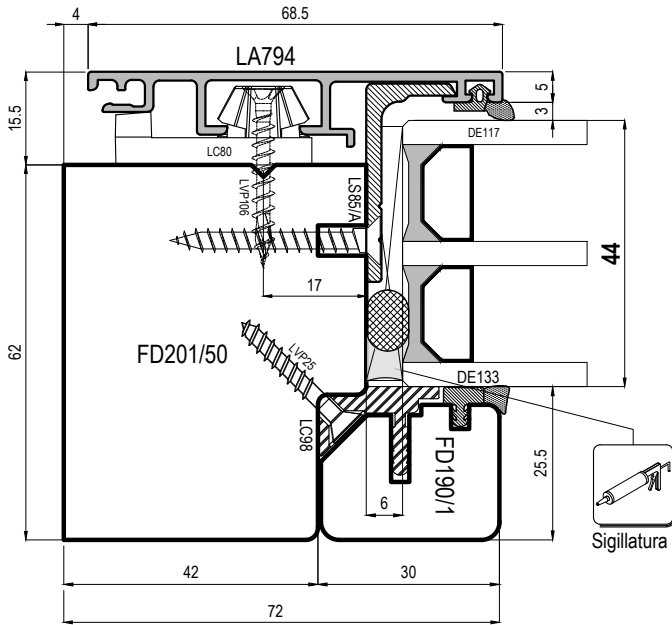
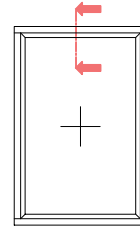
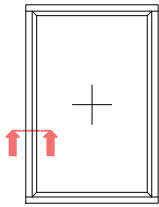

# Istruzioni per il montaggio del vetro fisso

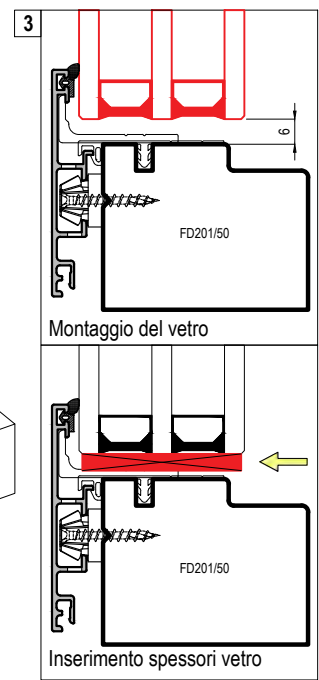
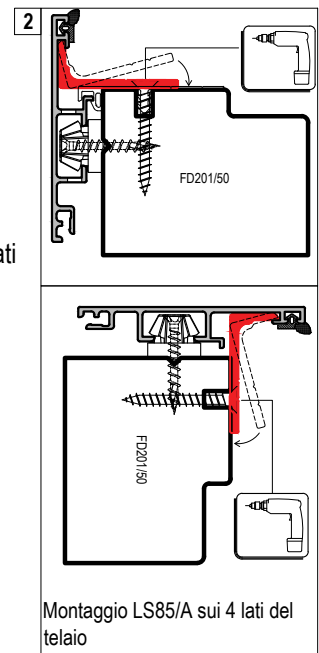
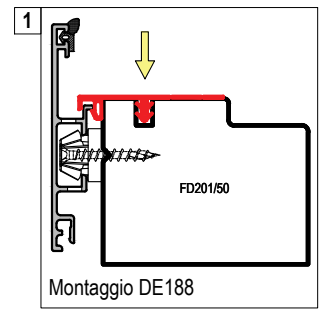
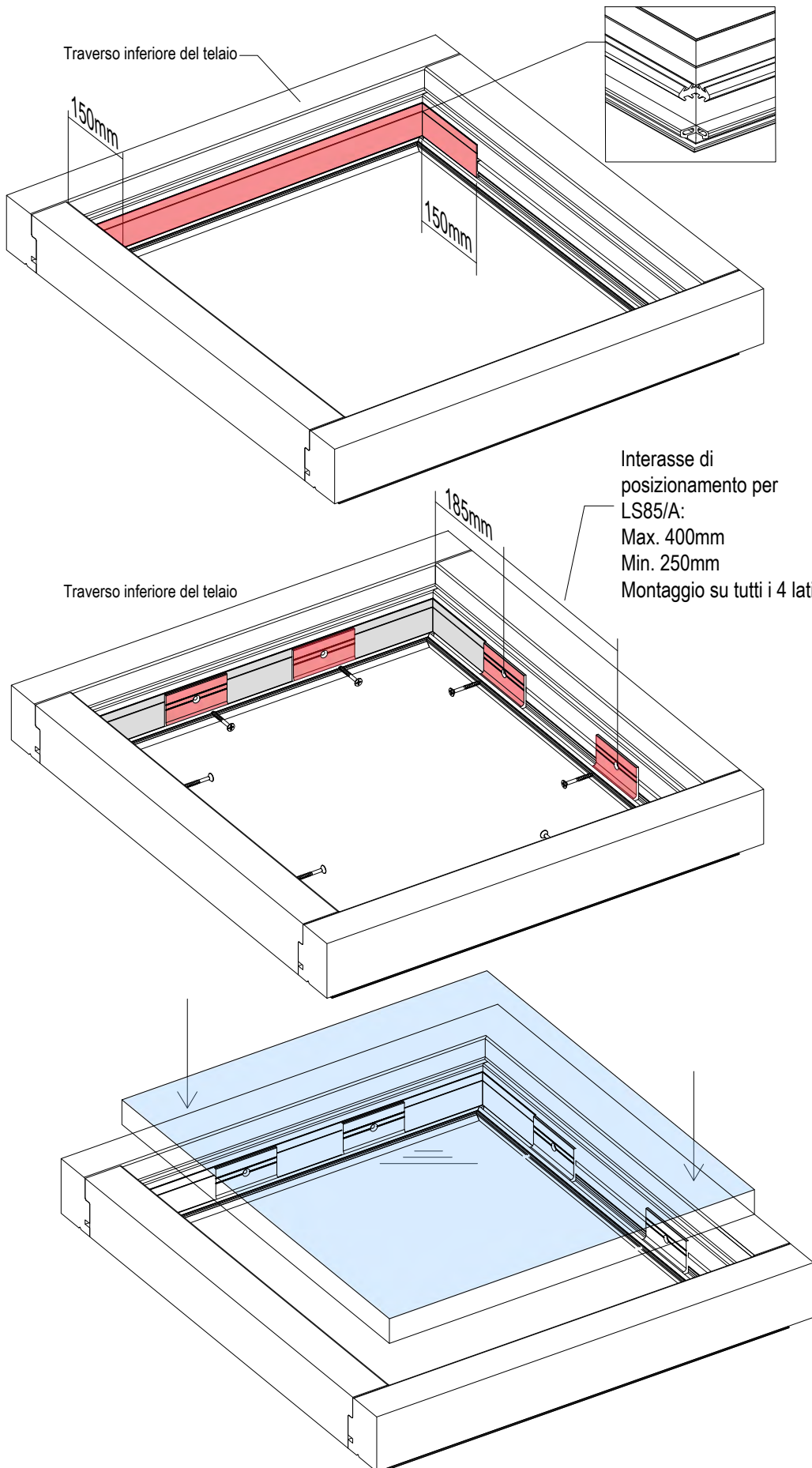

# Istruzioni per il montaggio del vetro fisso

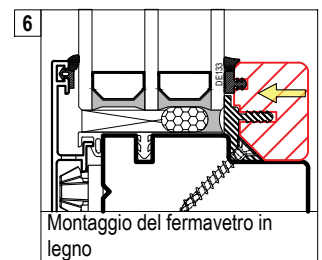
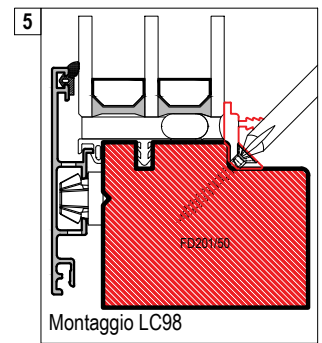
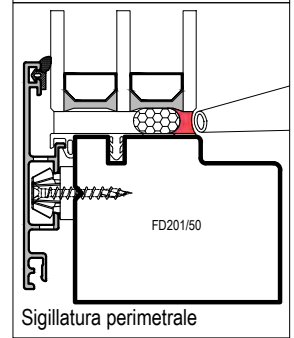
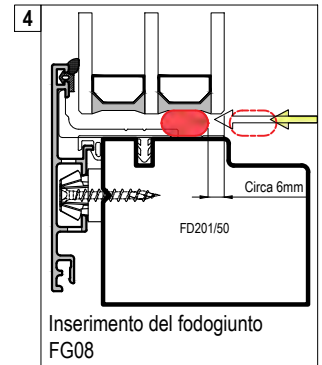
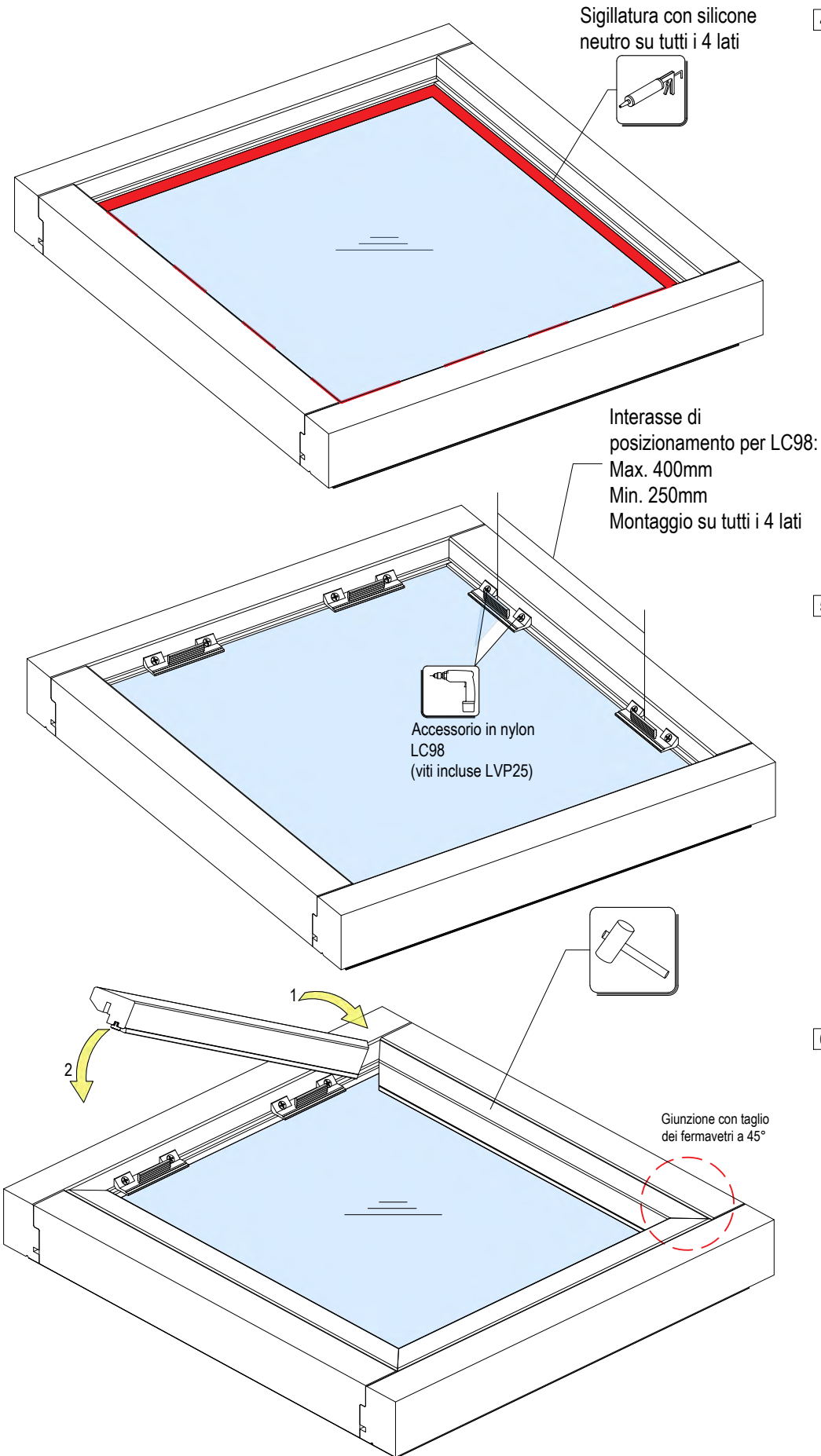



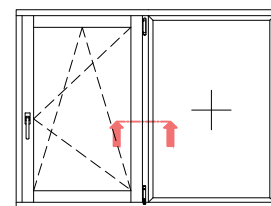
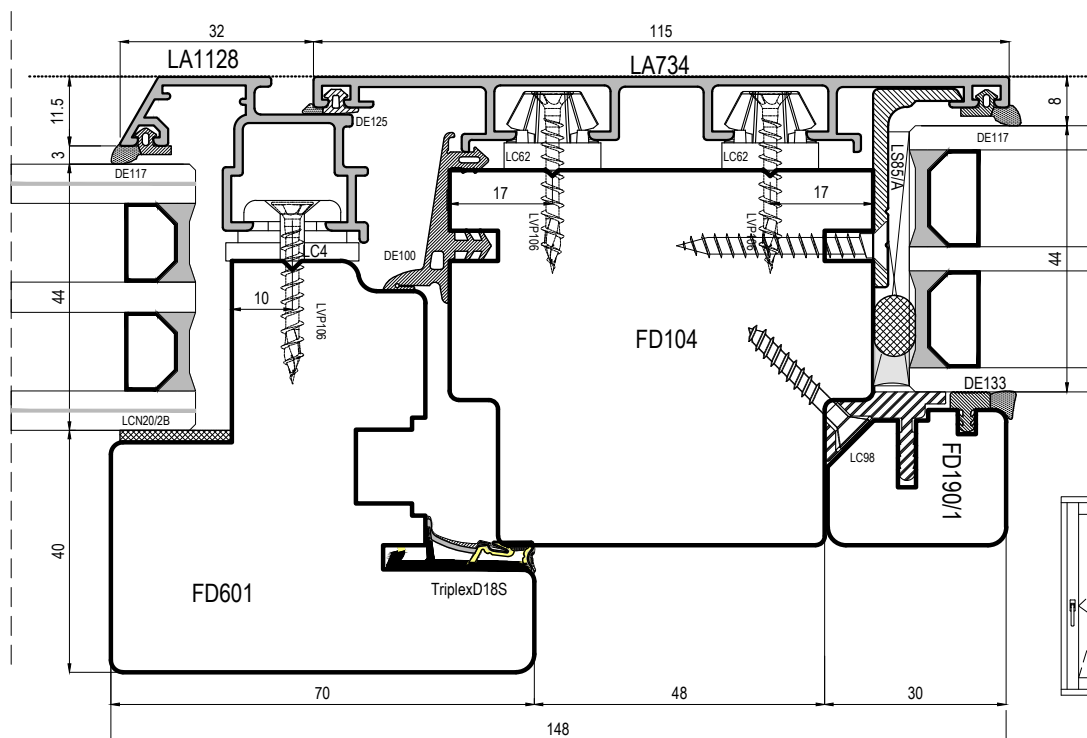
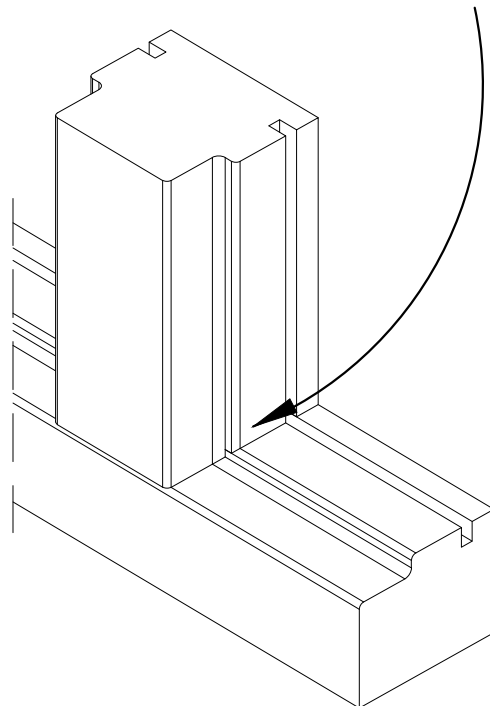
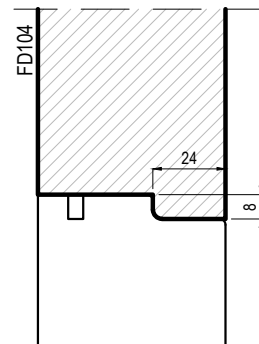
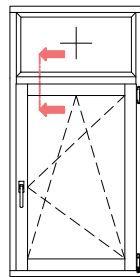
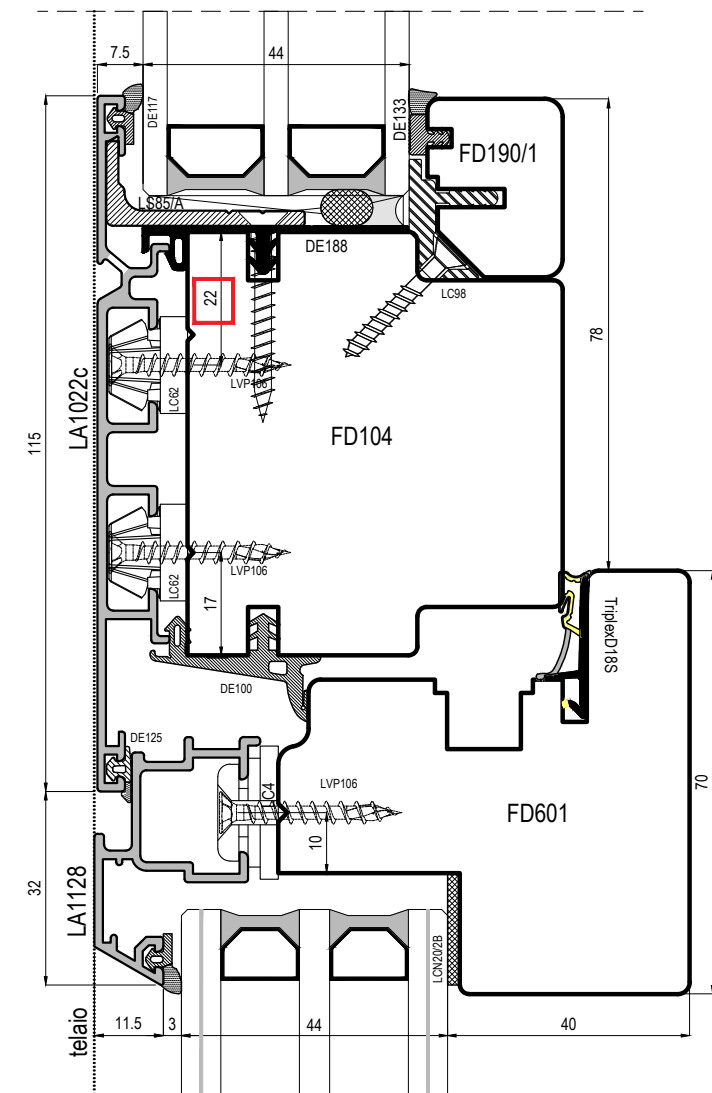

uni\_one - Sistema Complanare

Scala 0.8:1

CT uni\_one Complanare-ver.00/02.24

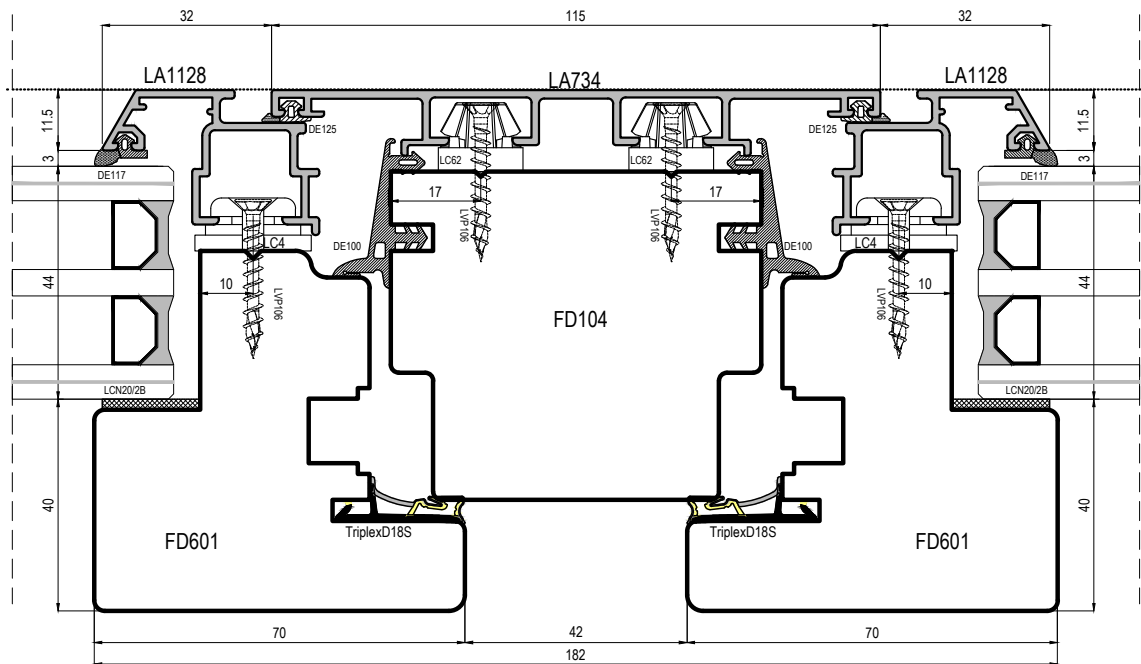
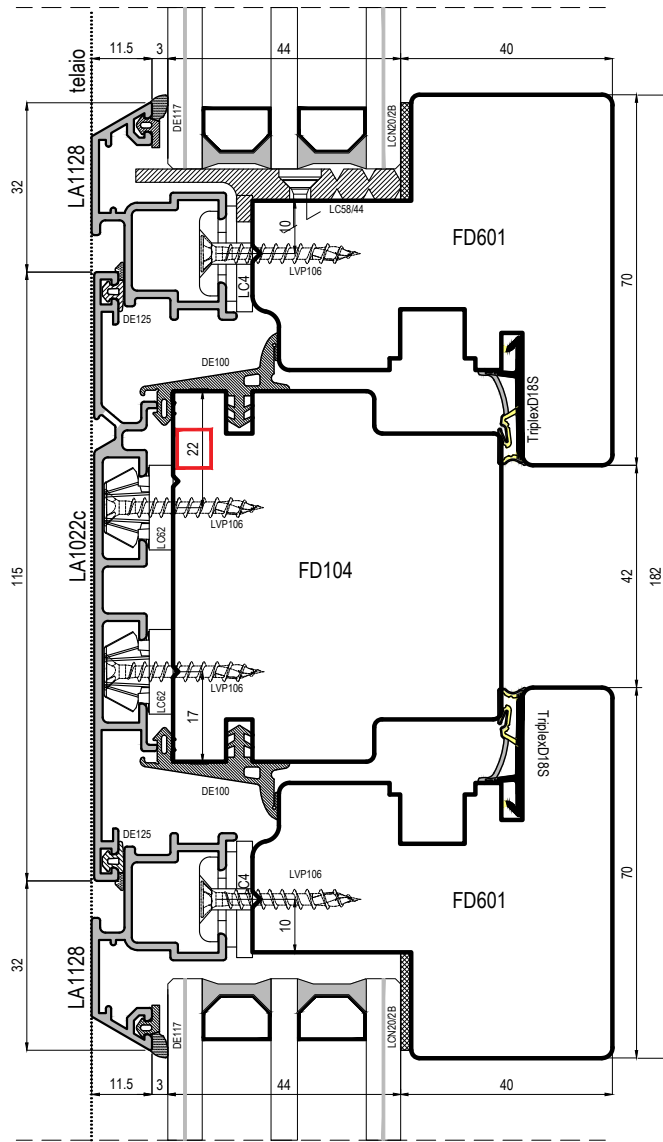
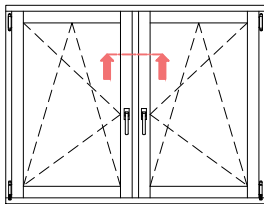
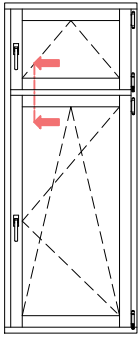

## Particolare giunzione a croce con FD104

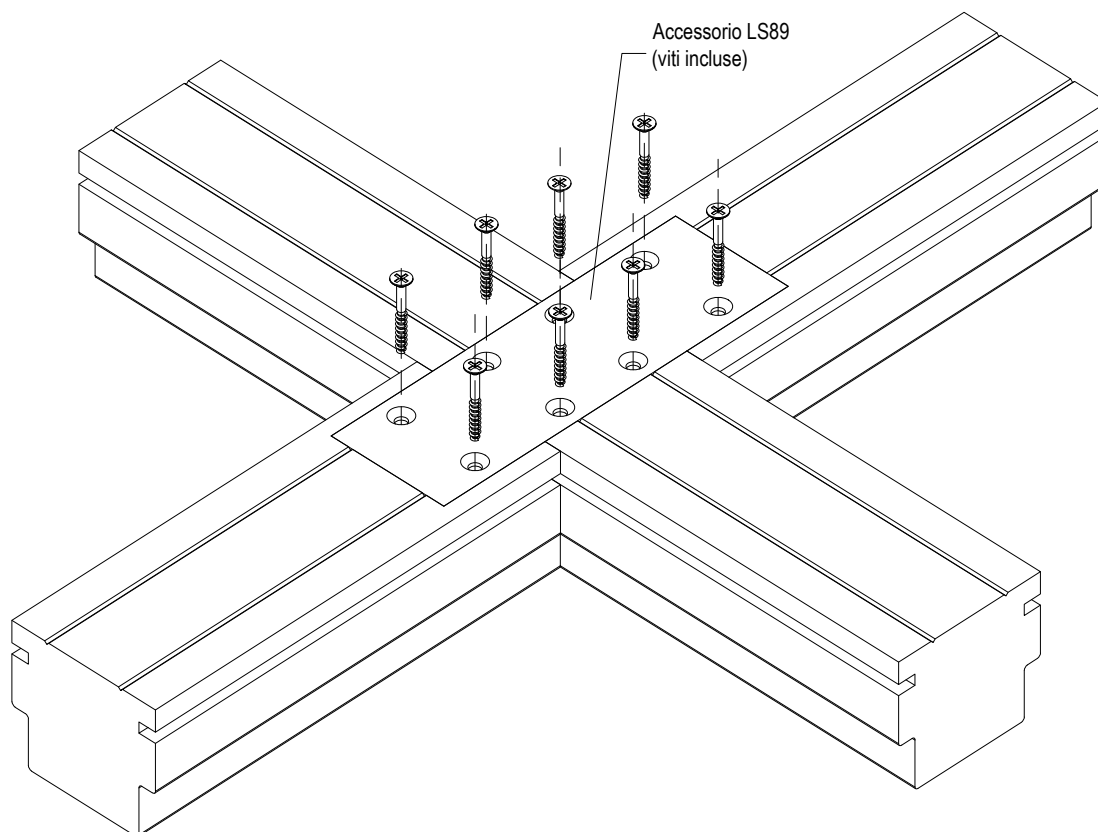
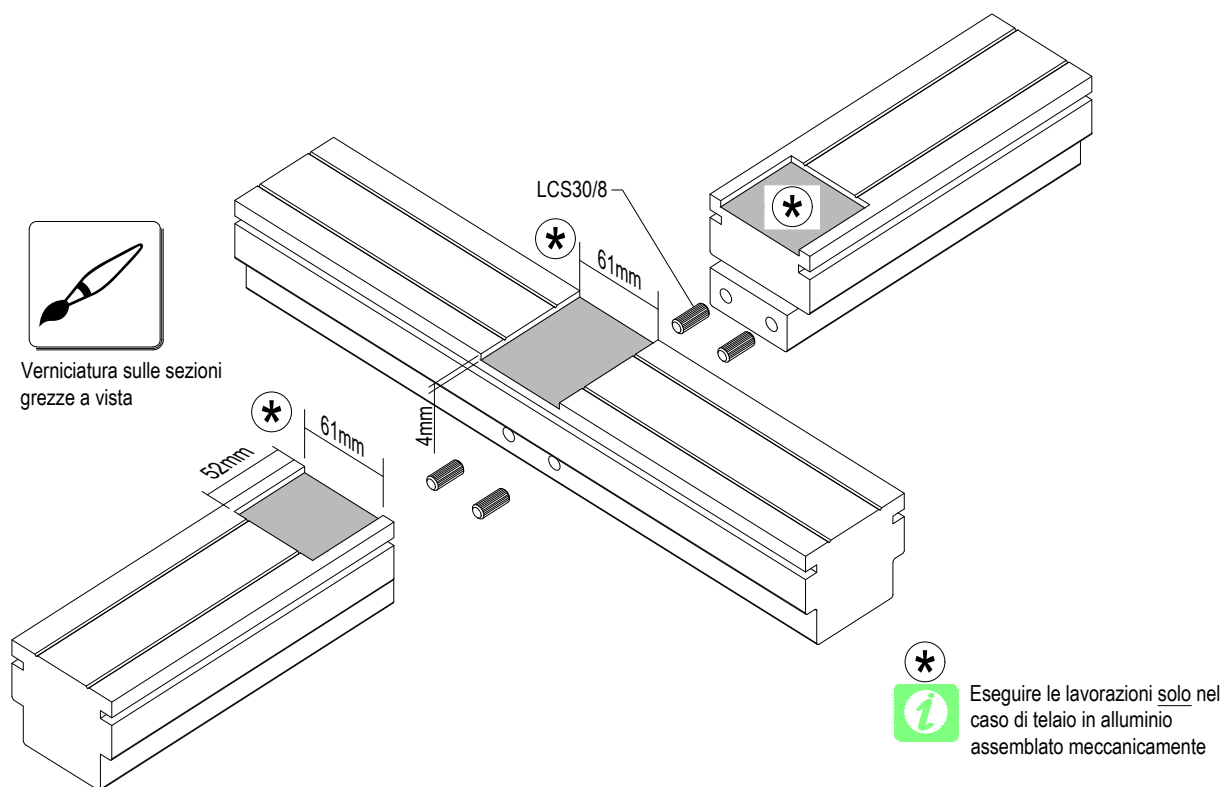



Modifica giunzione tra profilo montante e traverso telaio

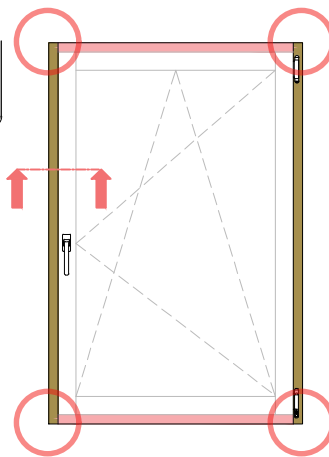
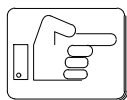

Verniciatura sulle sezioni grezze a vista

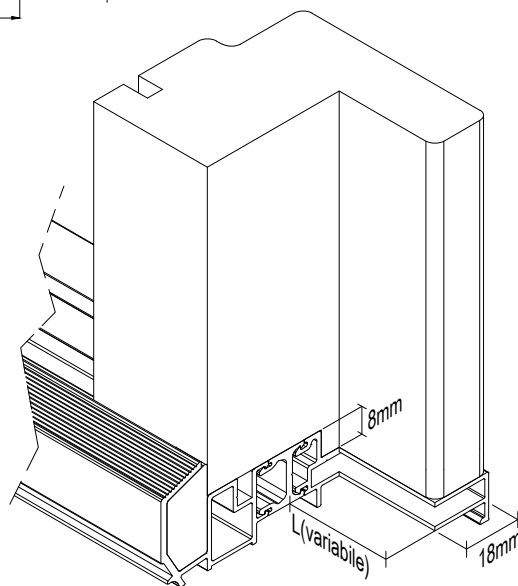
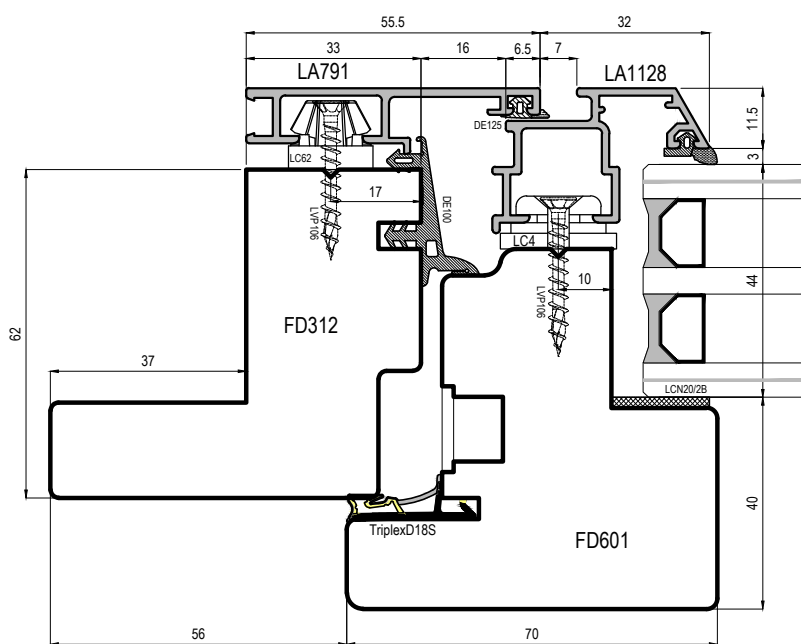
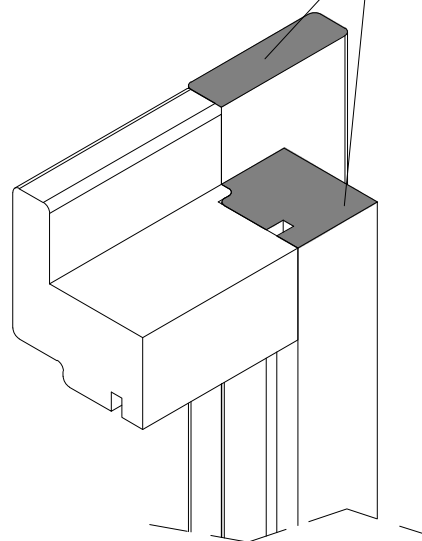
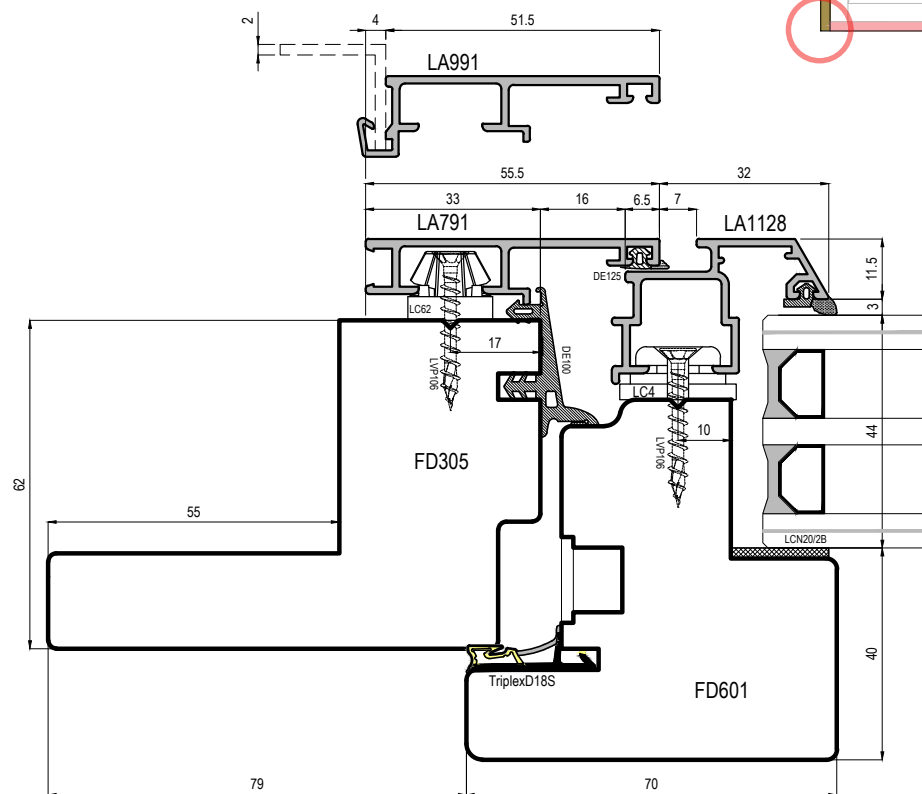
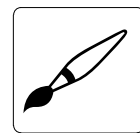

Telaio	Misura L
FD312	37 mm
FD305	55 mm

uni\_one - Sistema Complanare

Scala 0.7:1



Modifica giunzione tra profilo montante e traverso telaio

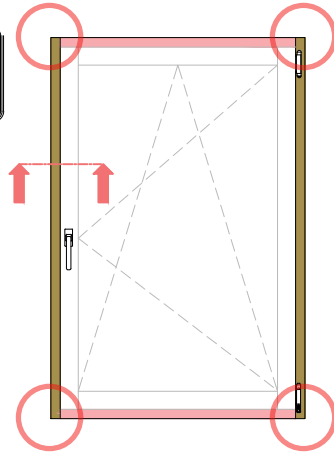
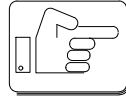

Verniciatura sulle sezioni grezze a vista

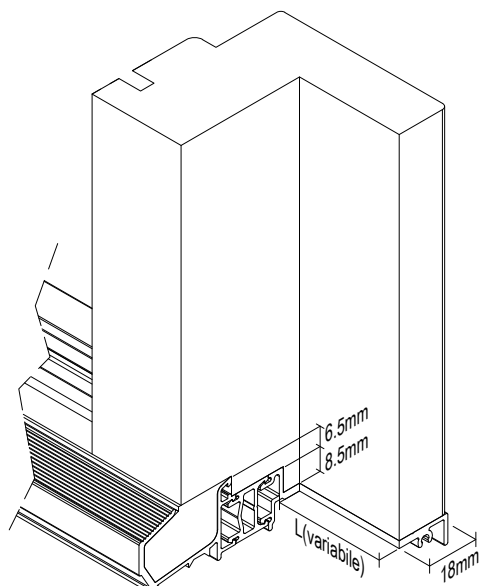
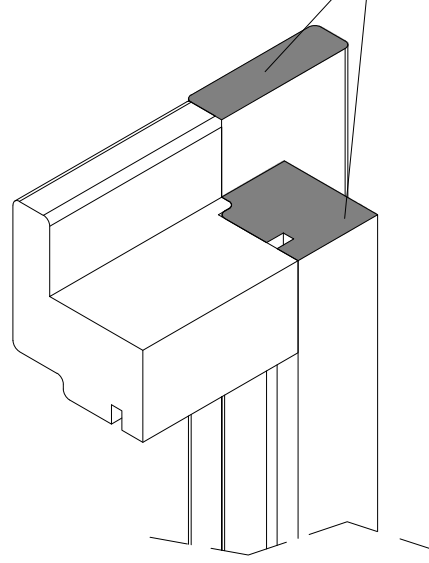

Soglia PA289T

Telaio	Misura L
FD312	37 mm
FD305	55 mm

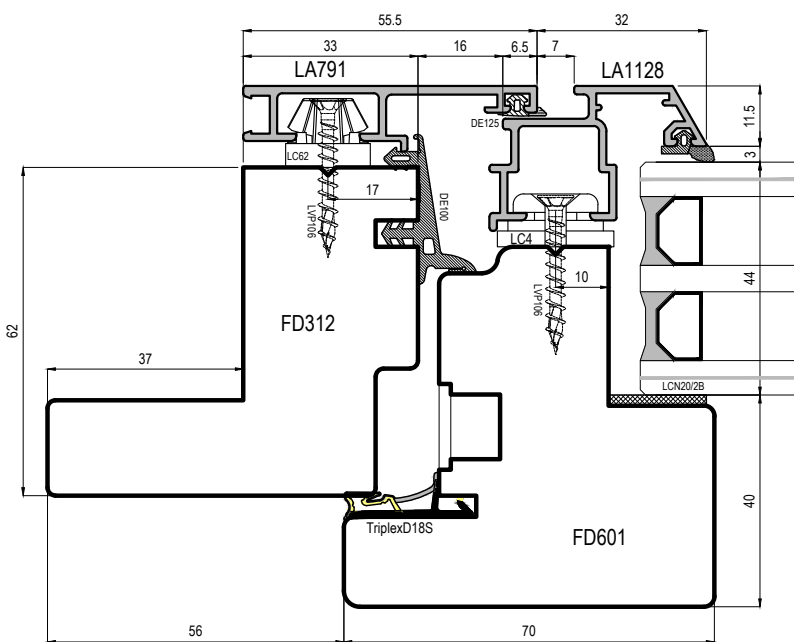
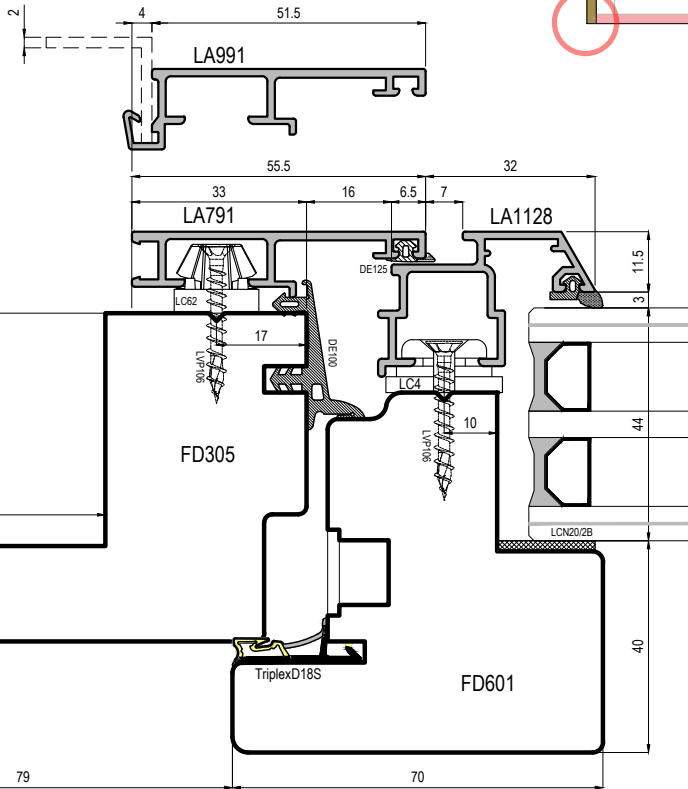

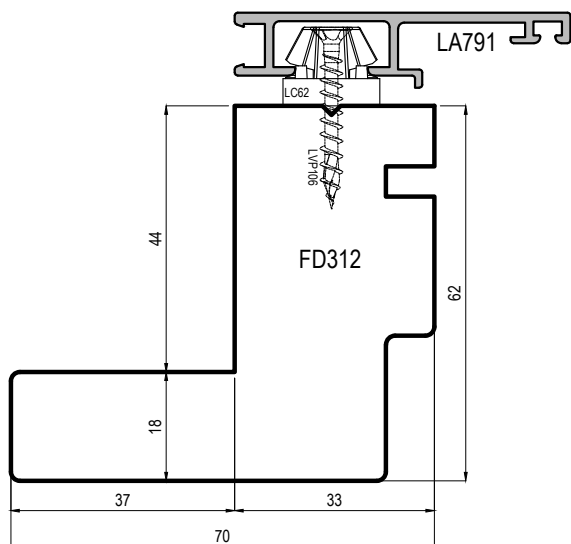

Compensatore trasverso inferiore per FD312

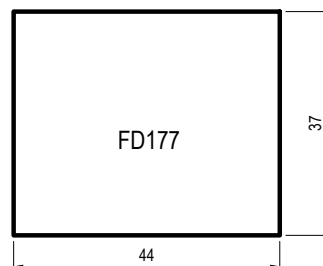

Traverso inferiore ribassato

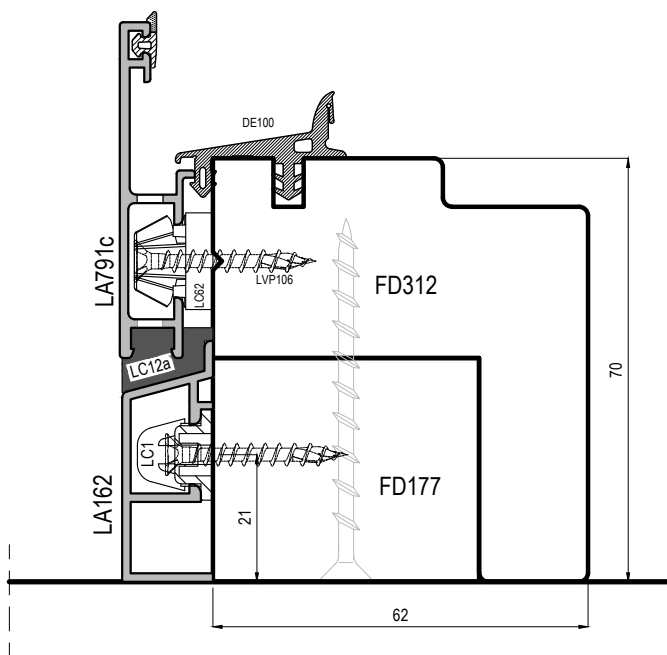
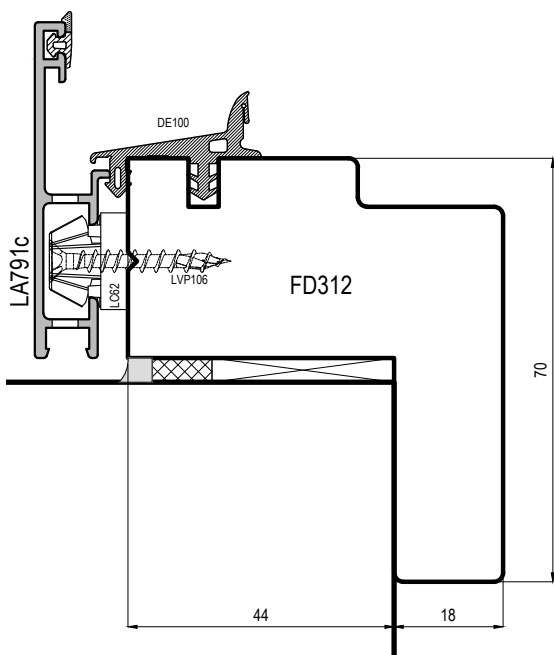
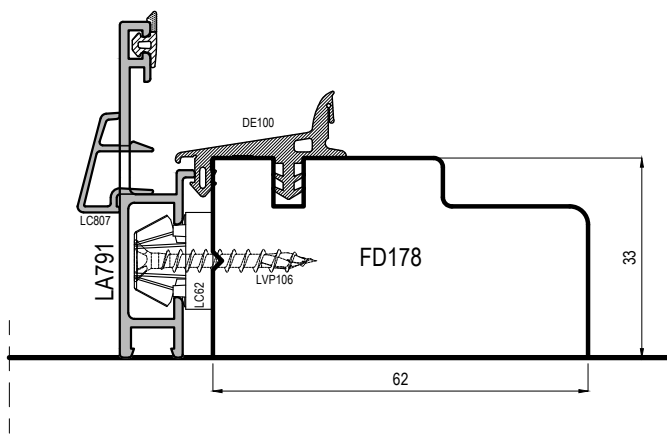
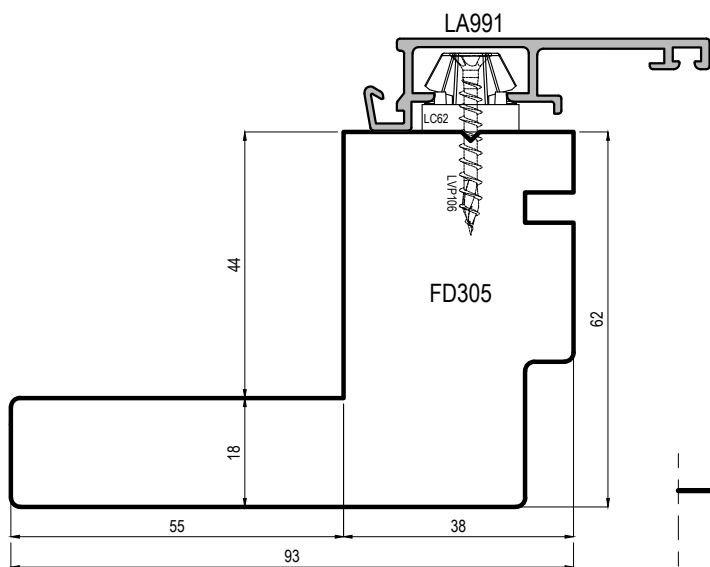
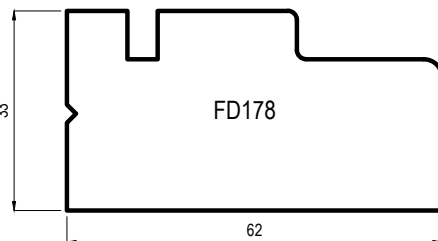

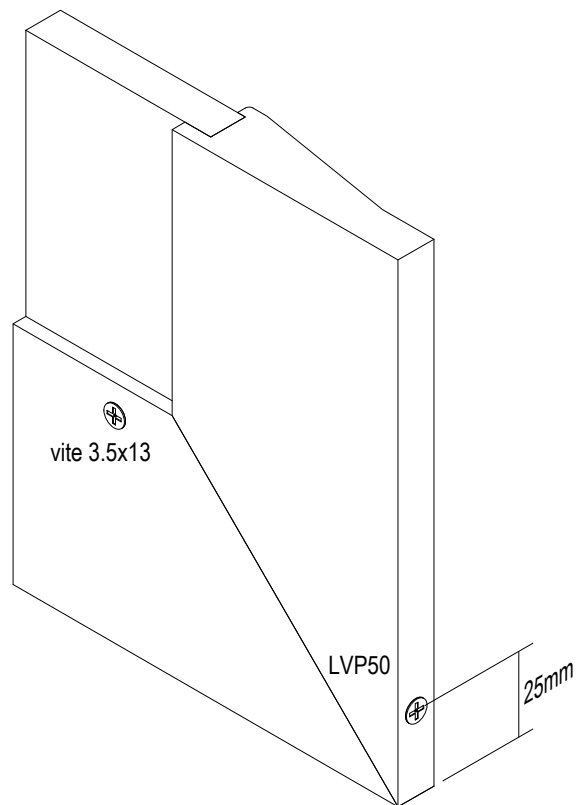
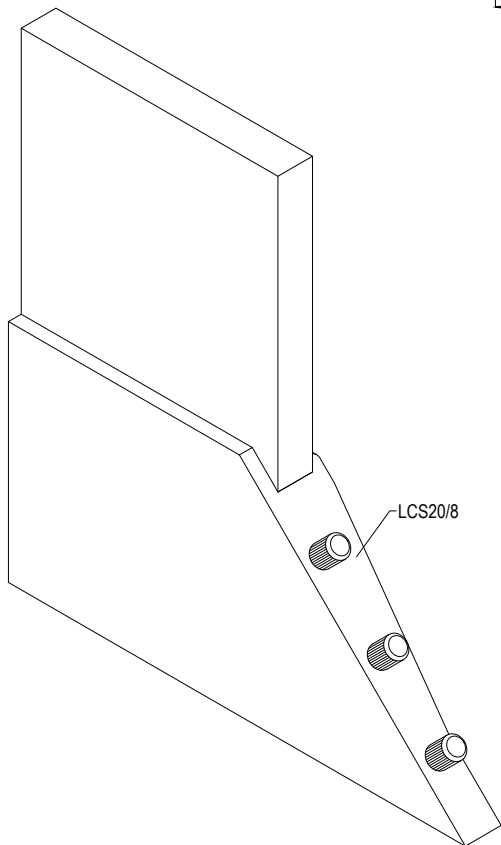
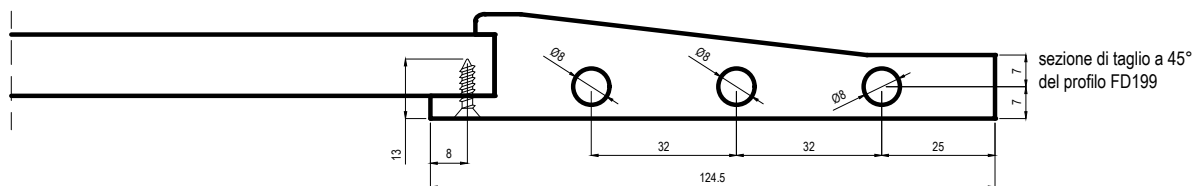
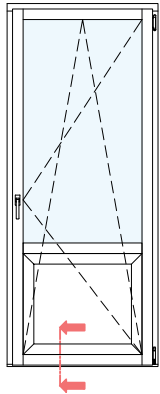
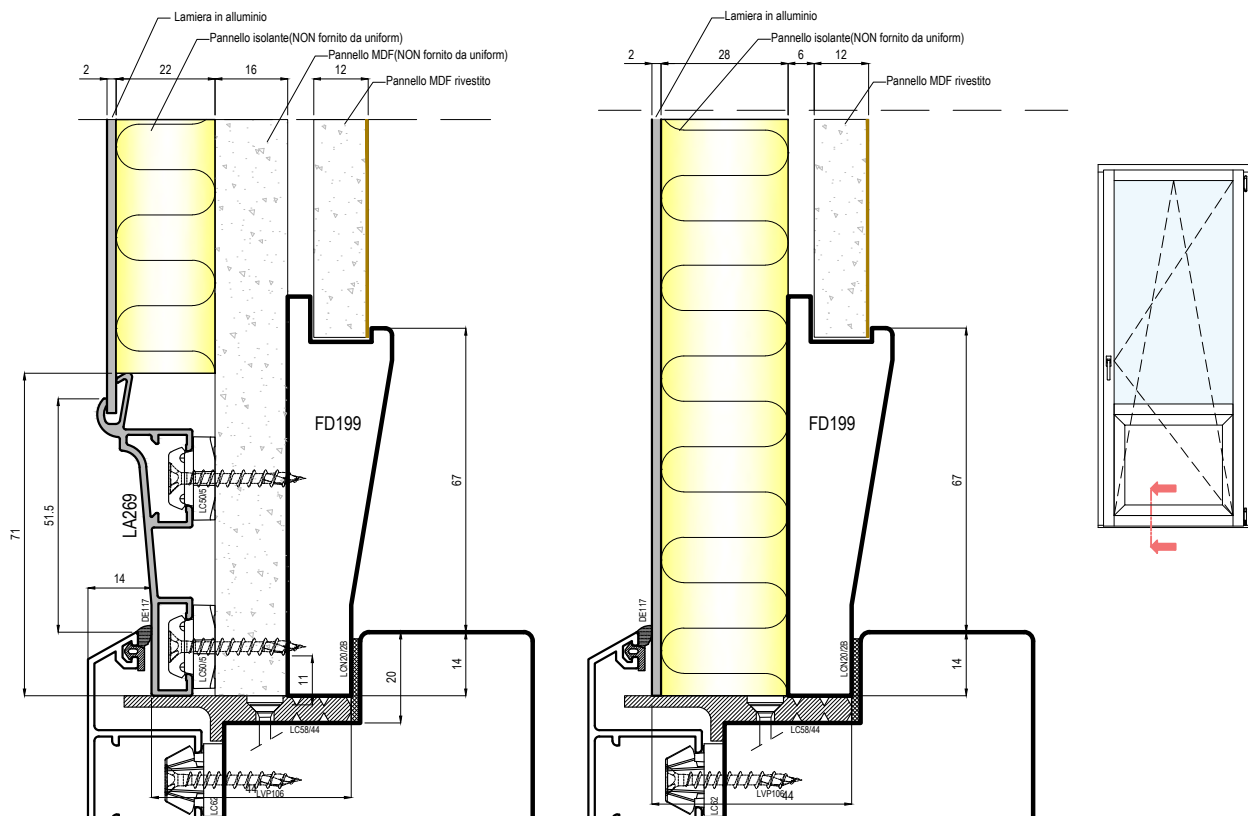

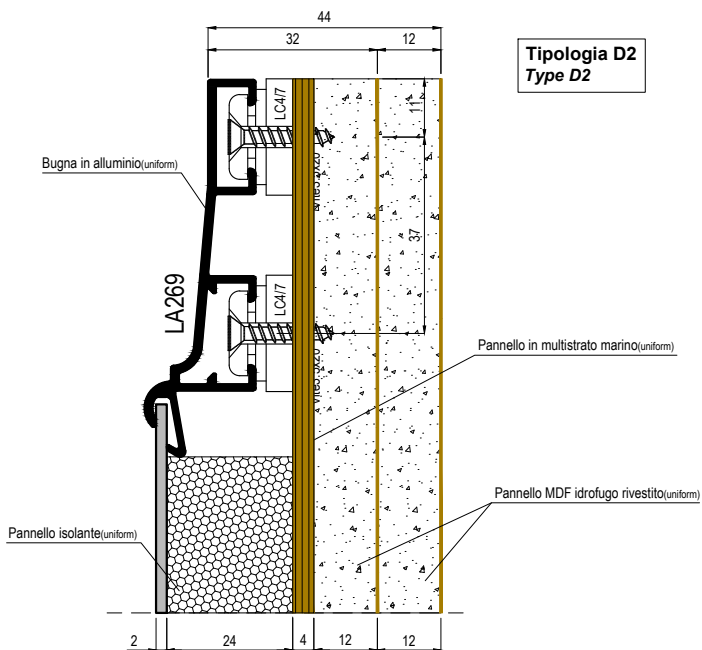
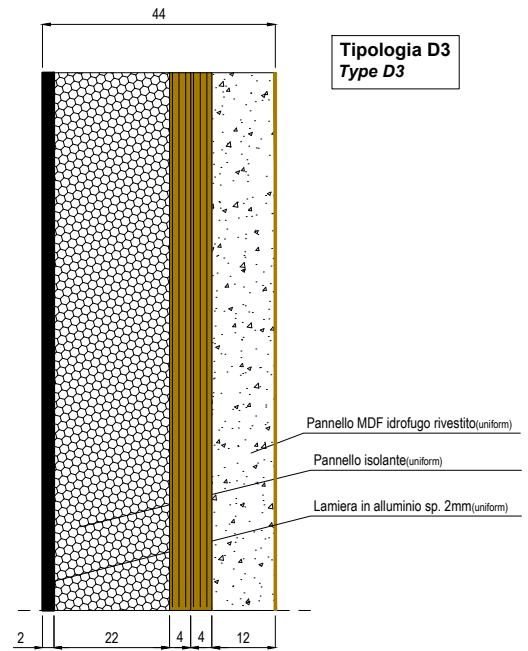
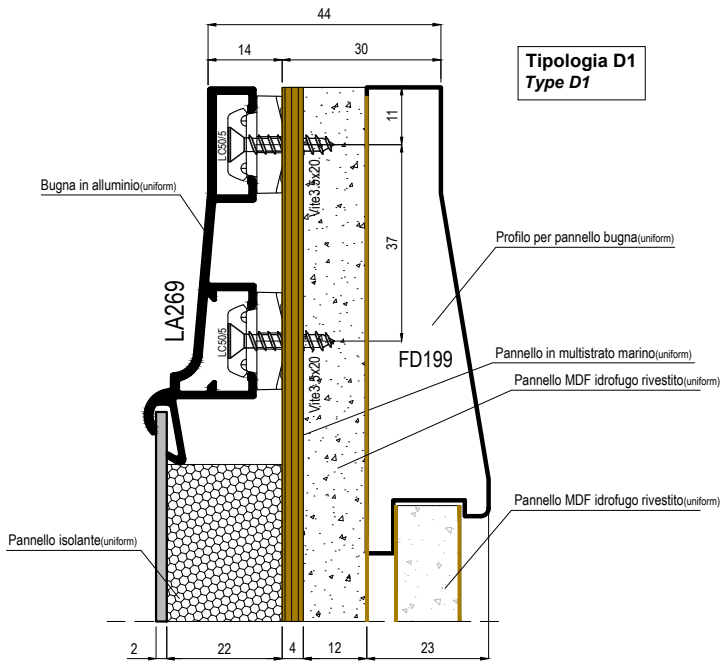



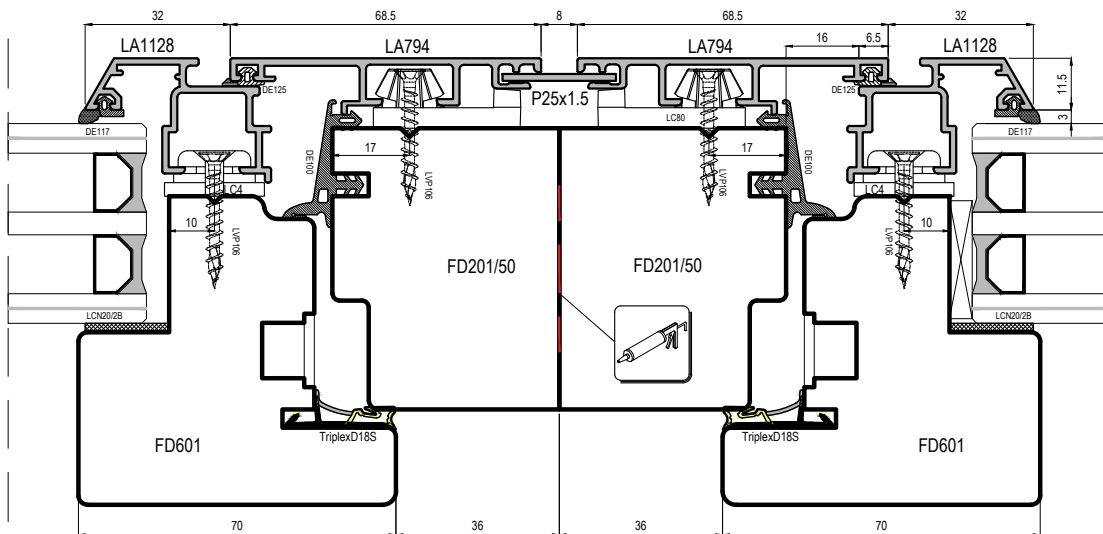
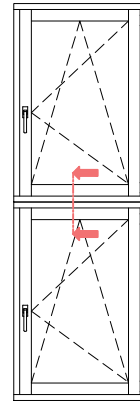
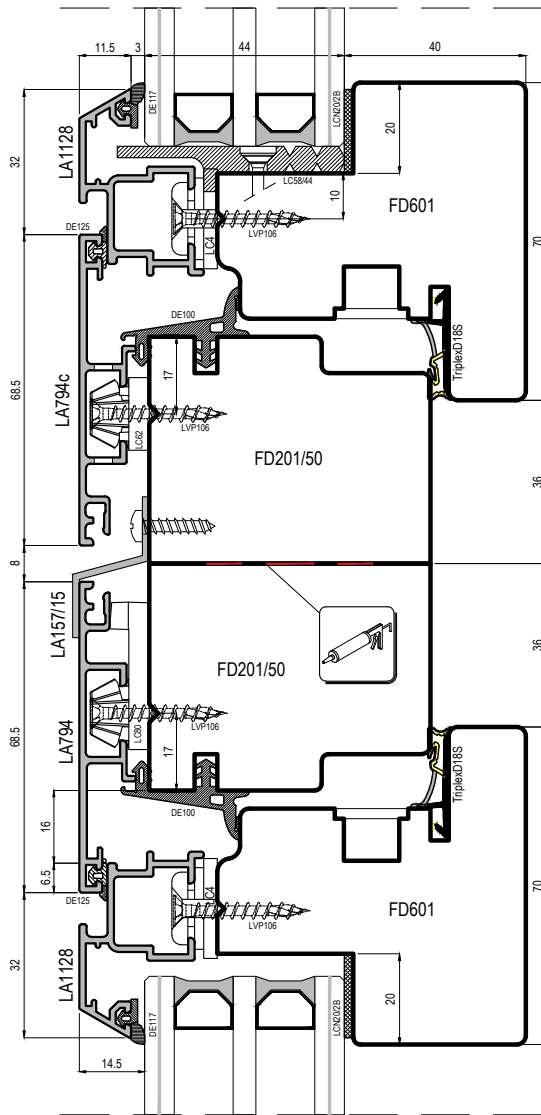
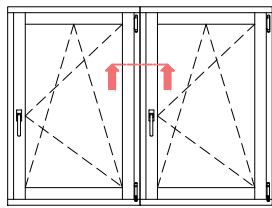

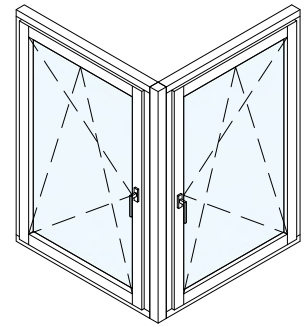
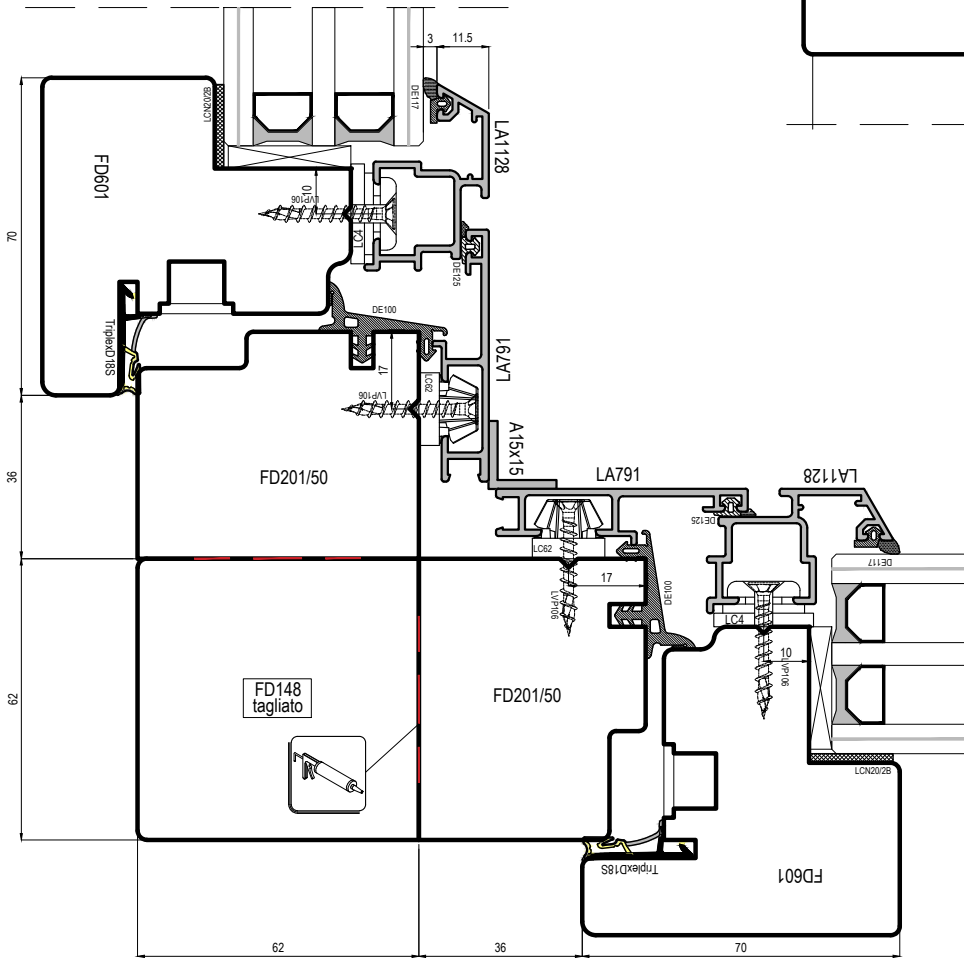
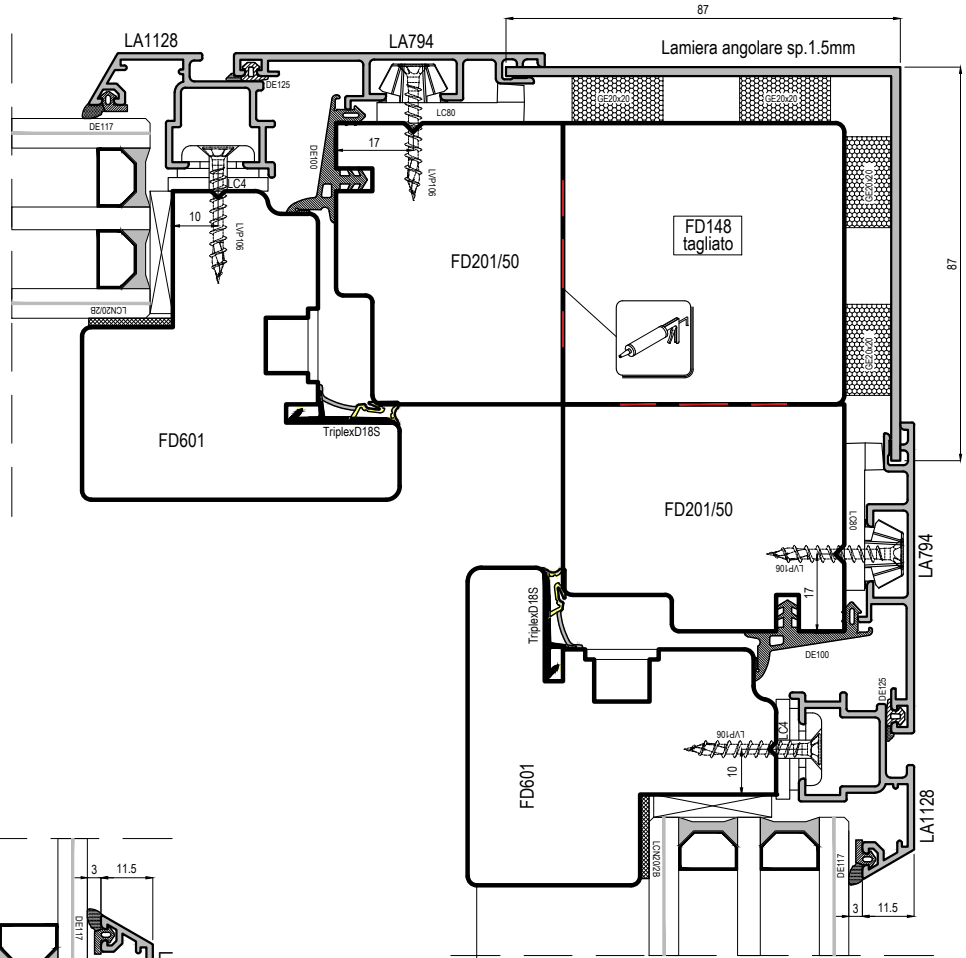
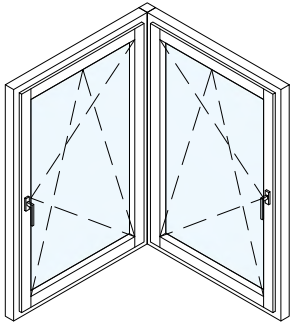



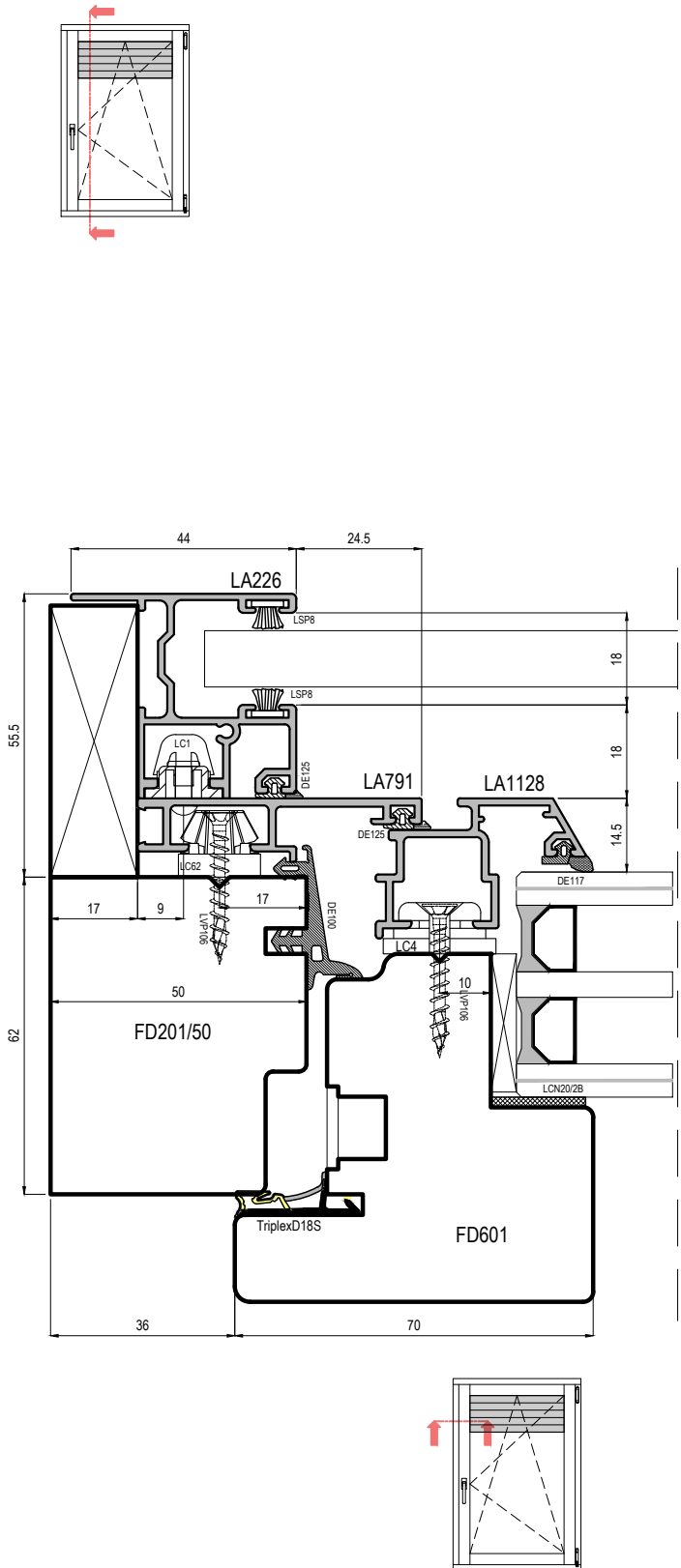
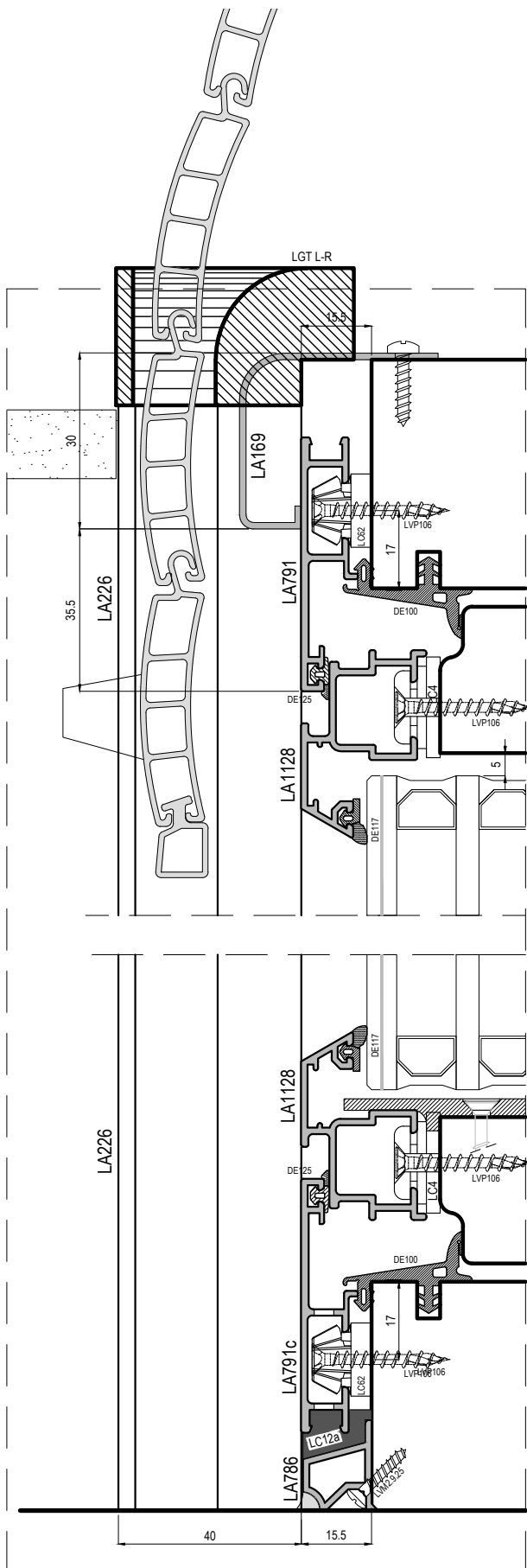

uni\_one - Sistema Complanare

Scala 0.7:1

CT uni\_one Complanare-ver.00/02.24



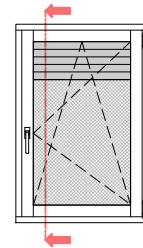
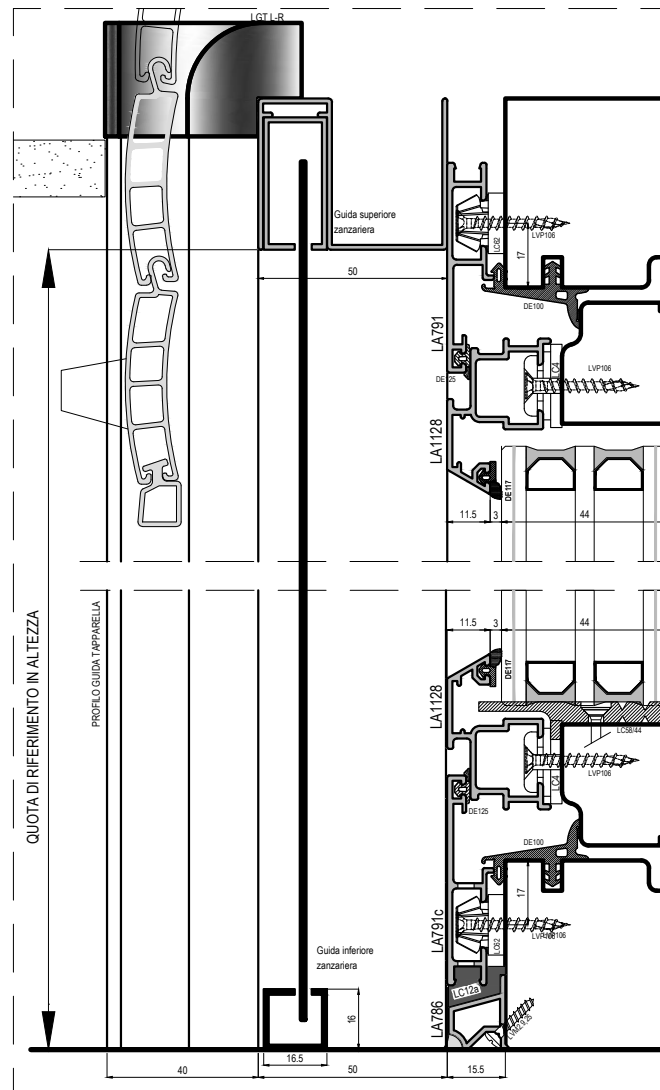
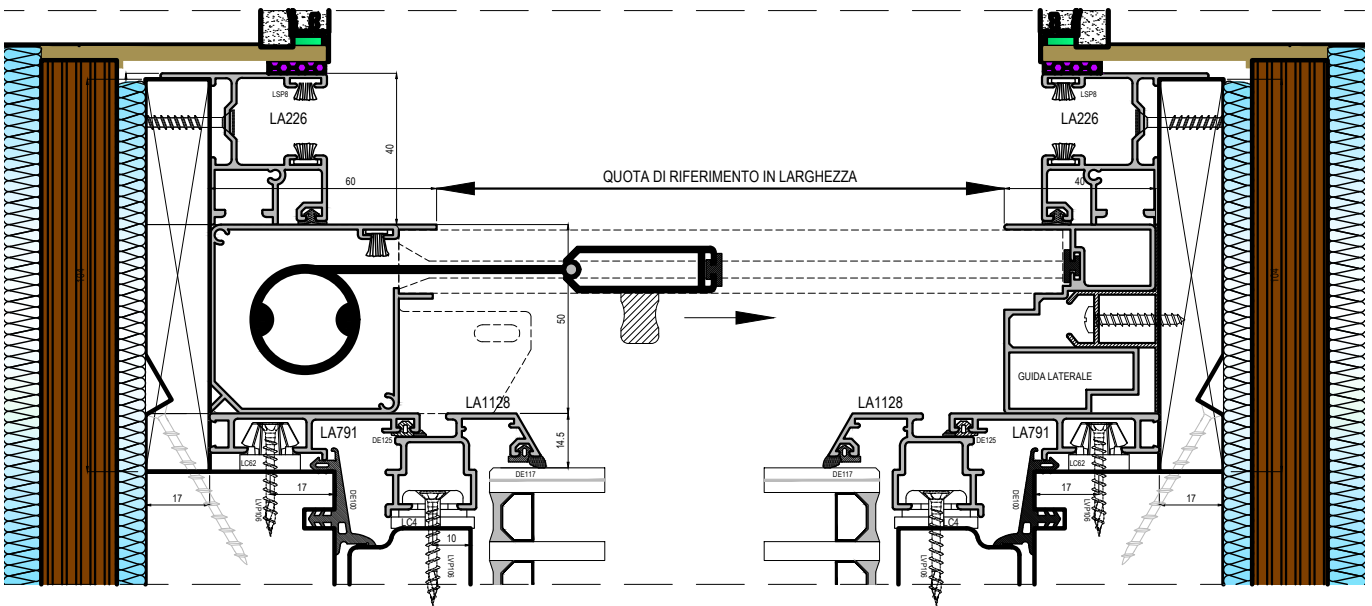
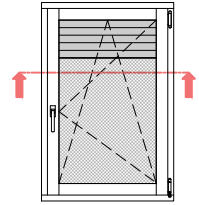

uni\_one - Sistema Complanare

Scala 1:2

CT uni\_one Complanare-ver.00/02.24

Produced with:  
uni\_one  
TECHNOLOGY

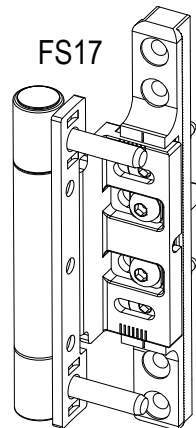
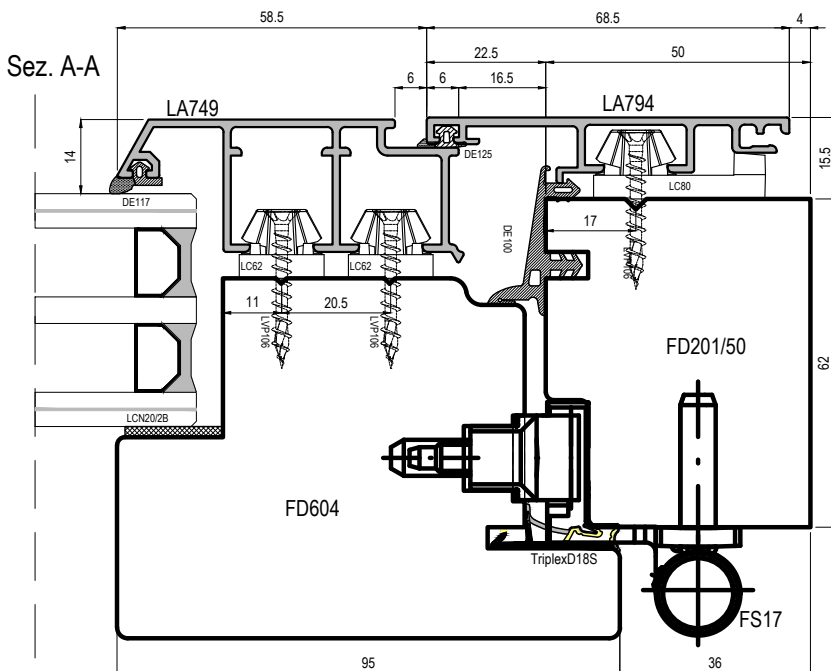
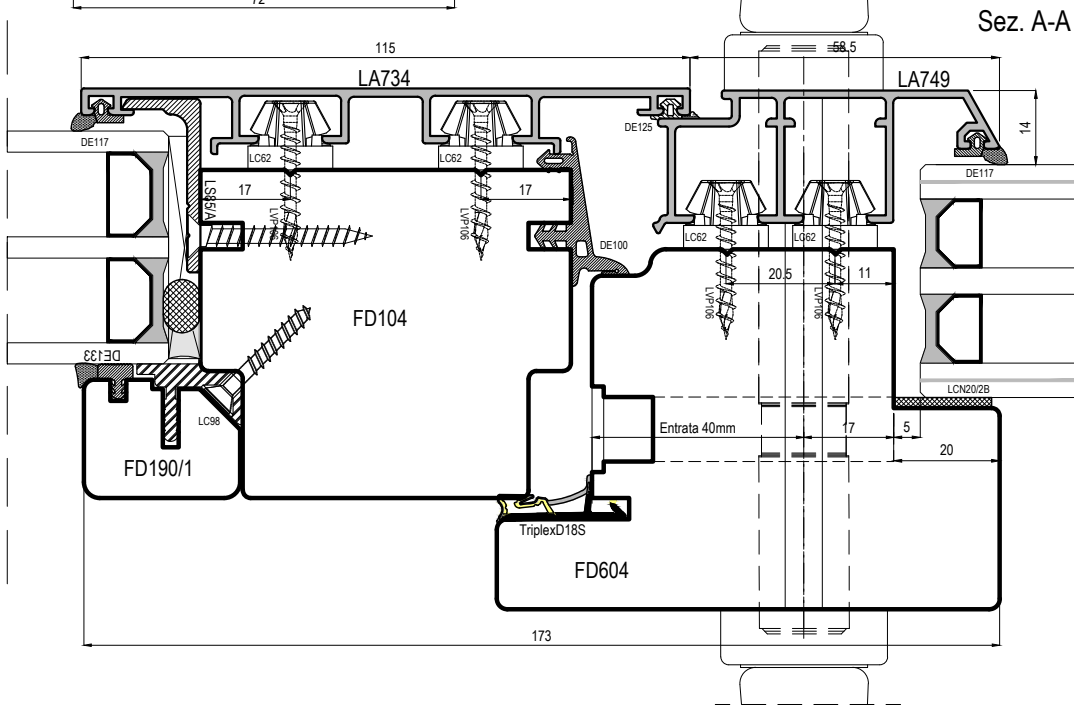
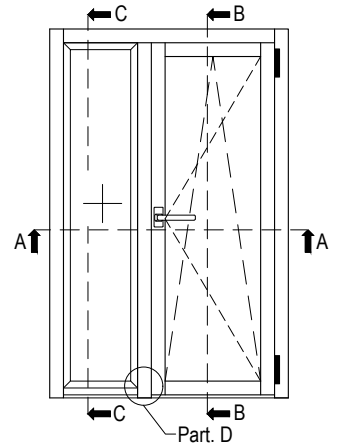
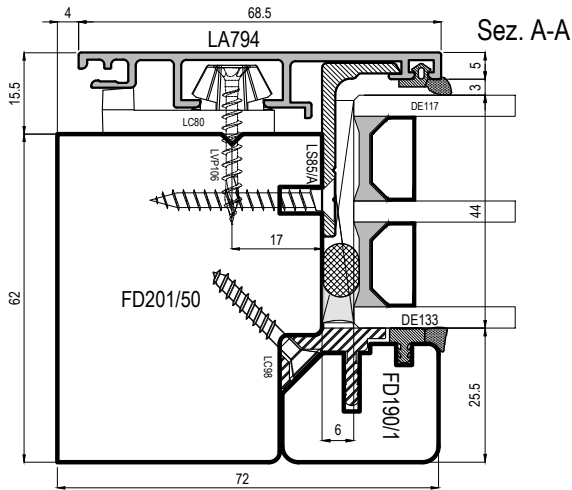

Posizionamento nel caso di terza cerniera

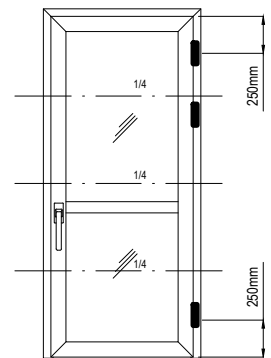

**Variante con FS17**(regolabile in 3 direzioni)

Finiture disponibili:

Plasticato bianco

Marrone RAL8003

Marrone scuro RAL8022

Ottonato

Cromato opaco

Bronzo chiaro

Portata con n°2 cerniere 140Kg

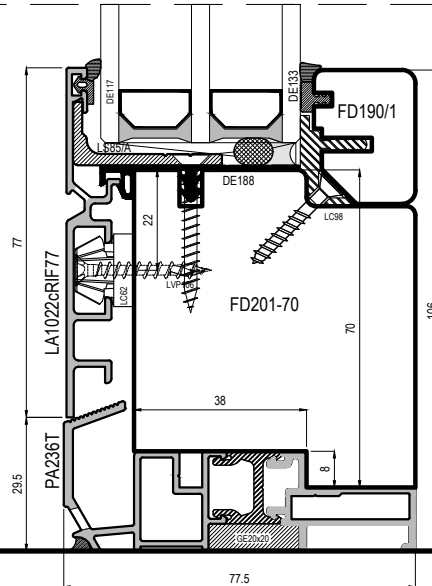
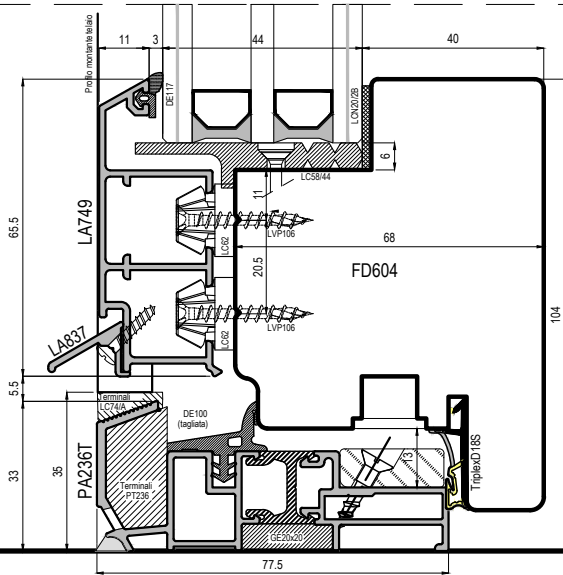
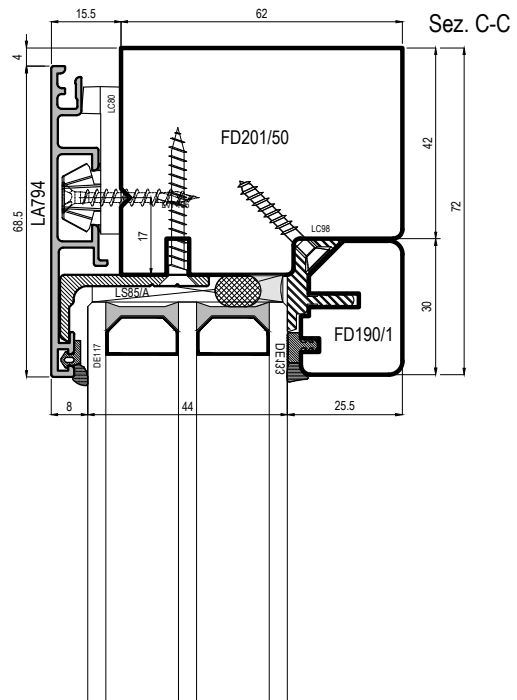
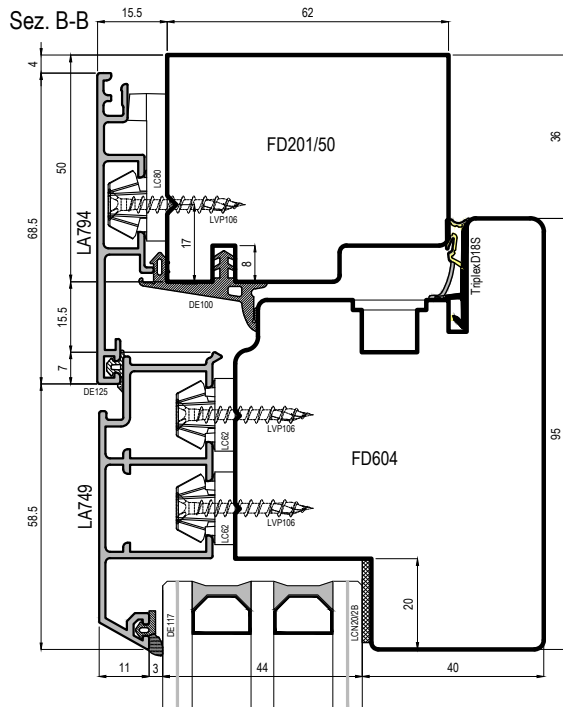
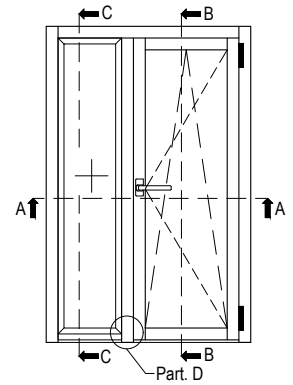
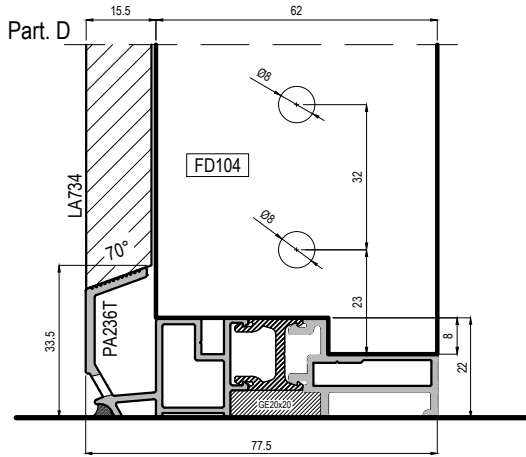







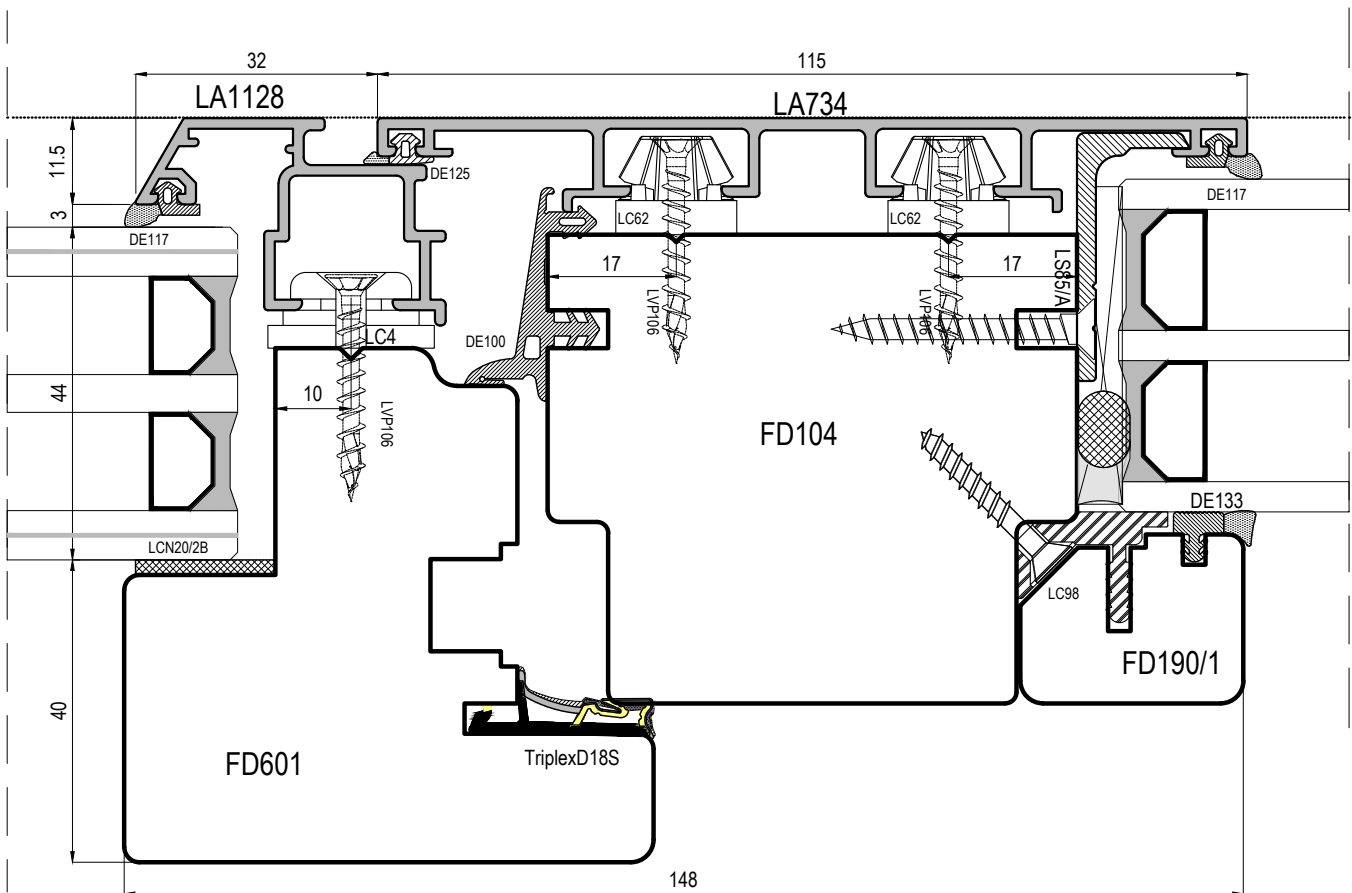
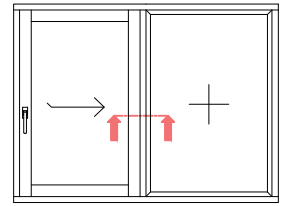

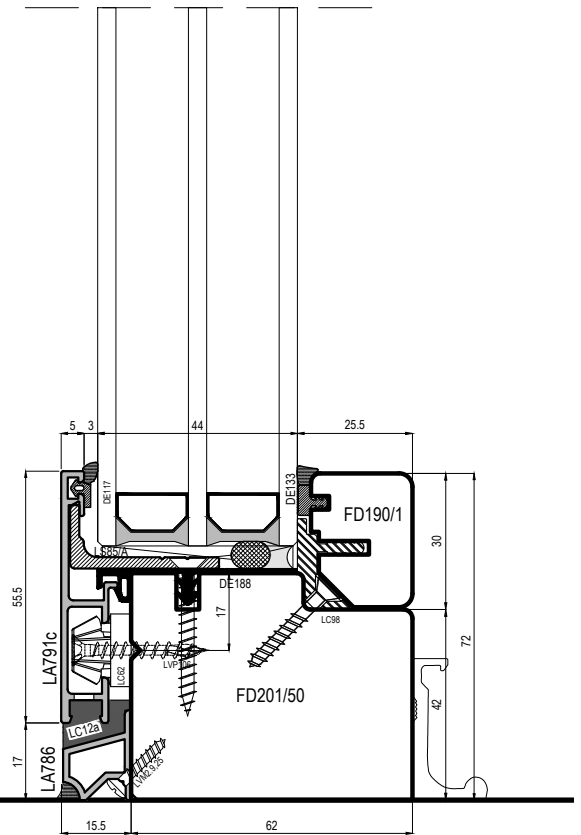
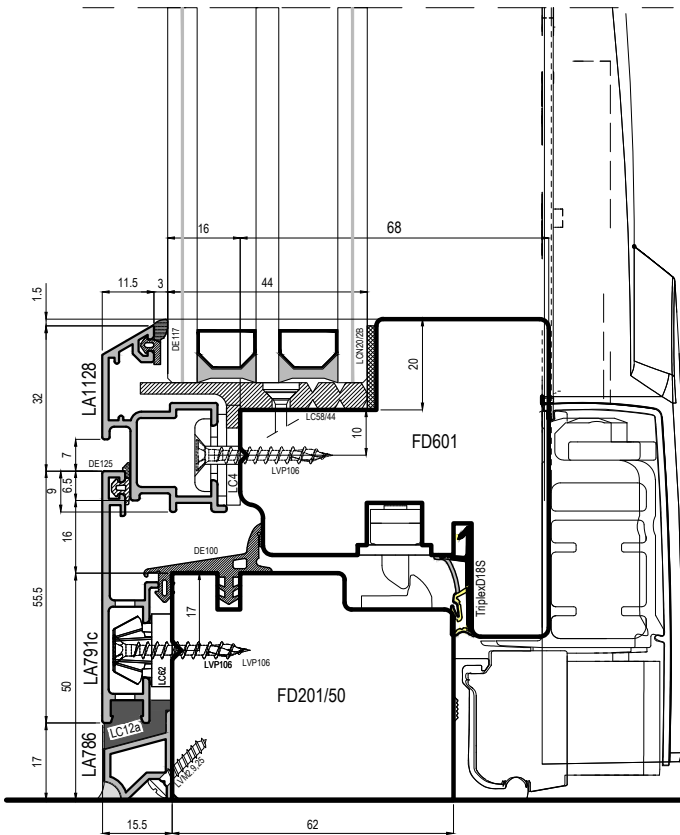
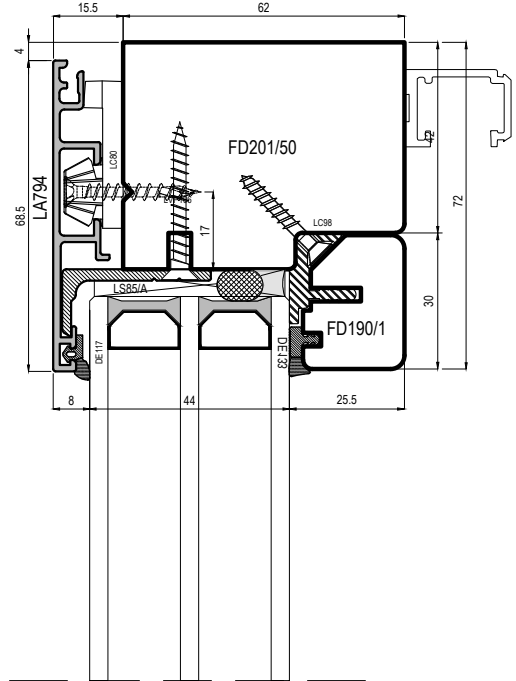
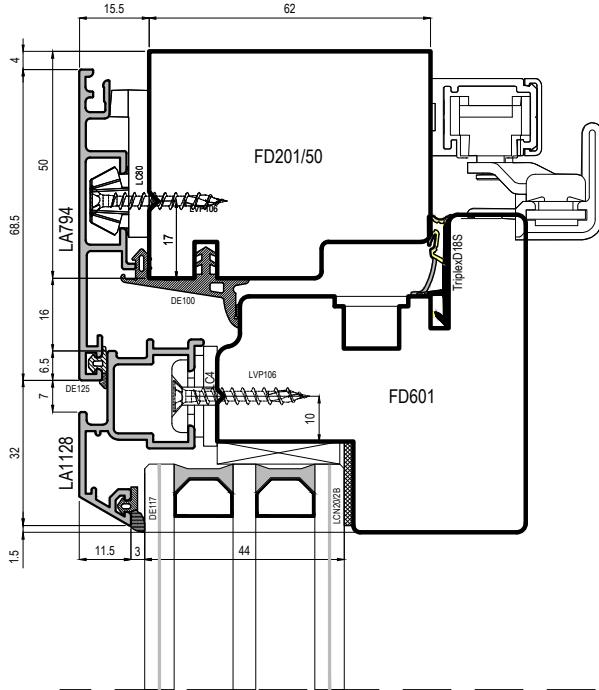
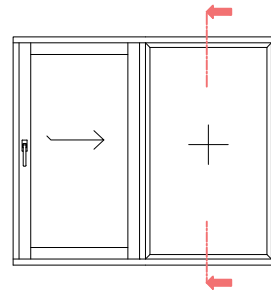
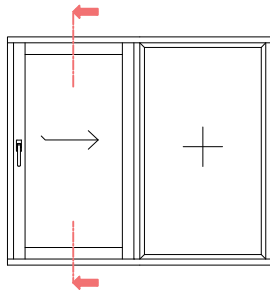

uni\_one - Sistema Complanare

Scala 0.6:1

CT uni\_one Complanare-ver.00/02.24

Nell'interesse di un continuo miglioramento dei prodotti, Uniform spa si riserva il diritto di variare le specifiche in qualsiasi momento senza previa notifica.

*In the interest of continued improvements to the products, Uniform spa reserve the right to change specifications at any time and without prior notification, and without any obligation*